

**TM 55-1520-248-23-9**

**TECHNICAL MANUAL**

**GLOSSARY**

**AVIATION UNIT AND  
INTERMEDIATE  
MAINTENANCE MANUAL**

**ALPHABETICAL INDEX**

**FOLDOUTS**

**ARMY MODEL  
OH-58D  
HELICOPTER**

DISTRIBUTION STATEMENT A: Approved for public release; distribution is unlimited.

---

**HEADQUARTERS, DEPARTMENT OF THE ARMY  
31 MARCH 1992**



**WARNINGS, CAUTIONS, AND NOTES**

Personnel performing troubleshooting procedures and practices which are included or implied in this technical manual shall observe the following warnings.

**WARNING**

An operating procedure, practice, etc., which if not correctly followed, could result in personal injury or loss of life.

**CAUTION**

An operating procedure, practice, etc., which if not strictly observed, could result in damage to or destruction of equipment.

**NOTE**

An operating procedure, condition, etc. which it is essential to highlight.

**SAFETY STEPS  
ELECTRICAL SHOCK**

Refer to FM 21-11 for electrical shock safety steps and procedures.

**WARNING****HIGH VOLTAGE**

The helicopter contains high voltage and shall be electrically grounded when parked. Serious burns and electrical shock can result from contact with exposed electrical wires or connectors.

**WARNING****HIGH VOLTAGE**

High voltage may be stored in the ignition system after operation of the APU. This high voltage can cause injury or death.

- Do not make contact with exposed wires or connectors.
- Allow at least five minutes after operation of the ignition system before disconnecting or removing ignition system components.
- Turn all power switches off before making any connections or disconnections.
- Observe instructions for grounding the power cable to discharge high voltage.
- For artificial respiration, refer to FM 21-11.

**WARNING**

**PITOT HEAT**

The pitot tube assembly is very hot during and immediately after operation requiring pitot heat. Severe burns will result if contacted by hands or other parts of the body.

**WARNING**

**LUBRICATING OILS HAZARDOUS**

Lubricating oils MIL-L-7808 and MIL-L-23699 contain materials hazardous to health. They can cause paralysis if swallowed. Prolonged contact with skin can cause irritation. Fire can result if exposed to heat or flames.

- Use only in areas with adequate ventilation.
- Wash hands thoroughly after handling.

**WARNING**

**BATTERY ELECTROLYTE**

Corrosive battery electrolyte (potassium hydroxide) requires rubber gloves, apron, and face shield when handling leaking batteries. Potassium hydroxide spilled on clothing or other material shall be washed immediately with clean water. If spilled on personnel, severe skin burns will result. Immediately start flushing the affected area with clean water and continue flushing until medical assistance arrives.

**WARNING**  
**RADIATION HAZARD**



**SELF-LUMINOUS DIALS**

Self-luminous instrument dials contain radioactive materials.

- If glass is broken or case becomes unsealed, avoid personal contact. Injury to personnel could result.
- Forceps or gloves made of rubber or polyethylene shall be used to pick up contaminated material.

**SELF-LUMINOUS DIALS (CONT)**

- Place material and gloves in a plastic bag. Seal bag and dispose of it as radioactive waste in accordance with AR 755-15 and TM 3-261.
- Repair procedure shall conform to requirements in AR 700-52.

**WARNING****POISONOUS LEAD OXIDE**

Poisonous lead oxide is a byproduct of fuels containing tetraethyl lead. Death or injury can result if this lead oxide is taken into the body through cuts or other external openings, or if inhaled.

- Wear rubber gloves and goggles when handling contaminated parts.
- If accidental exposure occurs, drench affected areas with large amounts of clear water.
- Obtain immediate medical attention.

**WARNING****TOXIC AND FLAMMABLE SOLVENTS**

Solvents used for cleaning are toxic and flammable. They irritate skin and cause burns. Fire can result from use near heat or open flame.

- Use only in a well-ventilated area.
- Wear rubber gloves.
- In case of contact, immediately flush skin or eyes with water for at least 15 minutes.
- Get immediate medical attention for eyes.



To look along the axis of a laser beam without protective glasses is extremely dangerous. Serious eye injury *will* result. Align the laser so that personnel are unlikely to inadvertently look along the axis of its beam.

---

Laser firing systems may store a charge. Take care to prevent accidental pulsing of the laser and to avoid electric shock. Personal injury may result.

---

Reflections from the laser beam are extremely dangerous. Serious eye injury will result. It is essential that all reflective material be removed from its path.

WARNING

SOLVENT

Drycleaning solvent is flammable and toxic, It can irritate skin and cause burns.

- Use only in well-ventilated area away from heat and open flame.
- Wear rubber gloves and goggles.
- In case of contact, immediately flush skin or eyes with water for at least 15 minutes,
- Get medical attention for eyes.

WARNING

SOUND LEVEL

Sound pressure levels in this helicopter during operating conditions exceed the Surgeon General hearing conservation criteria. Hearing protection devices, such as aviator helmet or ear plugs or ear sound suppressors are required to be worn by all personnel in and around the helicopter during its operation.

**WARNING**  
**COMPRESSED AIR**

Compressed air is dangerous when directed toward yourself or another person. The airstream or material blown by the airstream can cause injury, particularly to the eyes or face.

- Use goggles to protect eyes and face.
- Do not exceed 30 psig.
- Do not direct airstream toward yourself or another person.

**WARNING**  
**TOXIC AND FLAMMABLE FUELS**

Turbine fuels and fuel fumes are flammable. They cause drying and irritation of skin or eyes.

- Handle only in well – ventilated areas away from heat and open flame.
- Store in approved metal safety containers.
- Avoid prolonged or repeated contact with skin.
- Do not take internally.
- Wash contacted areas of skin after handling.
- Get immediate medical attention for eyes and irritated skin.

**WARNING**  
**METHYL-ETHYL-KETONE (MEK)**

MEK is flammable and toxic.

- It can irritate and cause burns.
- Use only in well – ventilated areas, away from heat or open flame.
- Wear rubber gloves and goggles.
- In case of contact, immediately flush skin or eyes with water for at least 15 minutes.
- Get medical attention for eyes.

WARNING

STRAY VOLTAGE

Stray voltages may exist in electronic equipment installed in the helicopter. These voltages present an explosive hazard to fuel and fuel fumes. Severe injury or death could result.

WARNING

MAIN AND TAIL ROTOR BLADES

Stay clear of turning main and tail rotor blades. Wind gusts, coast down or cyclic movement may cause the main rotor blade to flap down below the height of a person. Dangerous winds are created by the main rotor blades when blades are operated at or near top rpm. Adequate distance must be maintained from main and tail rotor blades during operation. Severe injury or death may result.

WARNING

ARMAMENT

Loaded weapons, or weapons being loaded or unloaded, shall be pointed in a direction which offers the least exposure to personnel or property in the event of accidental firing. Personnel should remain clear of hazardous area of all loaded weapons. Death or severe injury may result.

WARNING

HF ANTENNA

Ensure that HF antenna is not operating while performing maintenance. When operating, HF antenna emits infrared radiation that can cause radiation burns. If exposed to infrared radiation, seek medical aid immediately.

WARNING

ASBESTOS DUST

Avoid creating dust. Breathing asbestos dust may cause serious bodily harm,







By Order of the Secretary of the Army:

Official:

  
JOEL B. HUDSON  
*Administrative Assistant to the*  
**Secretary of the Army**  
03990

**DENNIS J. REIMER**  
*General, United States Army*  
**Chief of Staff**

**DISTRIBUTION:**

To be distributed in accordance with DA Form 12-31-E, block no. 1435, requirements for  
TM 55-1520-248-23-9.



CHANGE

NO. 5

HEADQUARTERS  
DEPARTMENT OF THE ARMY  
WASHINGTON, D.C., 20 June 1997

Aviation Unit and Intermediate  
Maintenance Manual

**ARMY MODEL  
OH-58D HELICOPTER**

DISTRIBUTION STATEMENT A: Approved for public release; distribution is unlimited

TM 55-1520-248-23-9, 31 March 1992, is changed as follows:

1. Remove and insert pages as indicated below. New or changed text material is indicated by a vertical bar in the margin. An illustration change is indicated by a miniature pointing hand

**Remove pages**

---

**Insert pages**

FP-174.1/(FP-174.2 blank) through  
FP-174.19/(FP-174.20 blank)

2. Retain this sheet in front of manual for reference purposes

**By Order of the Secretary of the Army:**

**DENNIS J. REIMER**  
*General, United States Army*  
*Chief of Staff*

Official:

**JOEL B. HUDSON**  
*Administrative Assistant to the*  
*Secretary of the Army*  
03784

DISTRIBUTION:

To be distributed in accordance with DA Form 12-31-E, block no. 1435, requirements for TM 55-1520-248-23-9.

CHANGE

NO. 4

HEADQUARTERS  
DEPARTMENT OF THE ARMY  
WASHINGTON, D.C. 15 September 1996

Aviation Unit and Intermediate  
Maintenance Manual

**ARMY MODEL  
OH-58D HELICOPTER**

DISTIRBUTION STATEMENT A: Approved for public release; distribution is unlimited.

TM 55-1520-248-23-9, 31 March 1992, is changed as follows:

1. Remove and insert pages as indicated below. New or changed text material is indicated by a vertical bar in the margin. An illustration change is indicated by a miniature pointing hand.

**Remove pages**

2. Retain this sheet in front of manual for reference purposes.

**Insert pages**

FP-199/(FP-200 blank)

**By Order of the Secretary of the Army:**

Dennis J. Reimer  
*General, United States Army  
Chief of Staff*

Official:

JOEL B. HUDSON  
*Administrative Assistant to the  
Secretary of the Army*  
02429

DISTRIBUTION:

To be distributed in accordance with DA Form 12-31-E, block no. 1435, requirements for TM 55-1520-248-23-9.

CHANGE  
NO. 3

HEADQUARTERS  
DEPARTMENT OF THE ARMY  
WASHINGTON, D. C., 6 January 1995

Aviation Unit and Intermediate  
Maintenance Manual

ARMY MODEL  
OH-58D HELICOPTERS

DISTRIBUTION STATEMENT A: Approved for public release; distribution is unlimited

TM 55-1520-248-23-9,31 March 1992, is changed as follows:

1. Remove and insert pages as indicated below. New or changed text material is indicated by a vertical bar in the margin. An illustration change is indicated by either a miniature pointing hand or a vertical bar in the margin.

Remove pages

i through iv  
FP-179/(FP-180 blank)  
FP-185/(FP-186 blank)  
FP-189/(FP-190 blank)  
FP-197/(FP-198 blank)

Insert pages

i through iv  
FP-179/( FP-180 blank)  
FP-185/(FP-186 blank)  
FP-189/( FP-190 blank)  
FP-197/( FP-198 blank)

2. Retain this sheet in front of manual for reference purposes.

By Order of the Secretary of the Army:

Official:

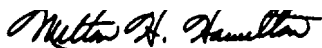

**MILTON H. HAMILTON**

*Administrative Assistant to the  
Secretary of the Army*

08082

GORDON R. SULLIVAN  
*General, United States Army  
Chief of Staff*

DISTRIBUTION:

To be distributed in accordance with DA Form 12-31-E, block no. 3433, requirements for  
TM 55-1520-248-23-9.





CHANGE

NO. 2

HEADQUARTERS  
DEPARTMENT OF THE ARMY  
WASHINGTON, D.C., 4 April 1994

Aviation Unit and Intermediate  
Maintenance Manual

ARMY MODEL OH-58D HELICOPTER

DISTRIBUTION STATEMENT A: Approved for public release; distribution is unlimited.

TM 55-1520-248-23-9, 31 March 1992, is changed as follows:

1. Remove and insert pages as indicated below. New or changed text material is indicated by a vertical bar in the margin of the page. An illustration change is indicated by either a miniature pointing hand or a vertical bar in the margin.

Remove pages

i through iv  
Index 1 through Index 10

FP-57/(FP-58 blank)

Insert Pages

i through iv  
Index 1 through Index 11/  
(Index 12 blank)

FP-57/(FP-58 blank)

2. Retain this sheet in front of manual for reference purposes.

**By Order of the Secretary of the Army:**

Official:

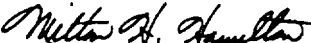
  
MILTON H. HAMILTON  
Administrative Assistant to the  
Secretary of the Army  
C6626

GORDON R. SULLIVAN  
General, United States Army  
Chief of Staff

DISTRIBUTION:

To be distributed in accordance with DA Form 12-31-E, block no. 1435, requirements for TM 55-1520-248-23-9.



CHANGE

NO. 1

HEADQUARTERS  
DEPARTMENT OF THE ARMY  
WASHINGTON D.C., 30 DECEMBER 1992

TECHNICAL MANUAL  
AVIATION UNIT AND INTERMEDIATE  
MAINTENANCE MANUAL

ARMY MODEL OH-58D HELICOPTER

DISTRIBUTION STATEMENT A: Approved for public release; distribution is unlimited.

TM 55-1520-248-23-9, 31 March 1992, is changed as follows:

1. Remove and insert pages as indicated below. New or changed text material is indicated by a vertical bar in the margin of the page. An illustration change is indicated by either a miniature pointing hand or a vertical bar in the margin.

Remove pages

Insert Pages

Index 1 through Index 70

Index 1 through Index 10

2. Retain this sheet in front of manual for reference purposes.

BY ORDER OF THE SECRETARY OF THE ARMY:

Official:

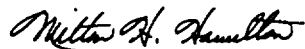

MILTON H. HAMILTON  
*Administrative Assistant to the  
Secretary of the Army*  
03154

GORDON R. SULLIVAN  
*General, United States Army  
Chief of Staff*

DISTRIBUTION:

To be distributed in accordance with DA Form 12-31-E, block no. 1435, requirements for TM 55-1520-248-23-9.



AVIATION UNIT AND INTERMEDIATE  
MAINTENANCE MANUAL

REPORTING ERRORS AND RECOMMENDING IMPROVEMENTS

You can help improve this manual. If you find any mistakes or if you know of a way to improve the procedures, please let us know. Mail your letter, DA Form 2028 (Recommended Changes to Publications and Blank Forms), or DA Form 2028-2 located in back of this manual direct to: Commander, U.S. Army Aviation and Troop Command, ATTN: AMSAT-I-MP, 4300 Goodfellow Blvd., St. Louis MO 63120-1798. A reply will be furnished to you.

TABLE OF CONTENTS

		PAGE
	HOW TO USE THIS MANUAL .....	V
CHAPTER 1	INTRODUCTION	
Section I	General Information .....	1-2
Section II	Equipment Description and Data.....	1-4
Section III	Principles of Operation .....	1-16
Section IV	Servicing .....	1-55
Section V	Lubrication .....	1-91
Section VI	Ground Handling and Jacking .....	1-98
Section VII	Mooring .....	1-124
Section VIII	Hoisting and Sling Loading .....	1-153
Section IX	Preventive Maintenance Inspections .....	1-177
Section X	Overhaul and Retirement Schedule.....	1-207
Section XI	Flight Safety Parts .....	1-209
CHAPTER 2	AIRFRAME	
Section I	Fuselage .....	2-2
Section II	Tailboom .....	2-186
Section III	Pylon .....	2-280
CHAPTER 3	ALIGNING GEAR	
SECTION I	Landing Gear .....	3-2
CHAPTER 4	POWER PLANT	
Section I	Engine Assembly .....	4-2
Section II	Air Induction .....	4-47
Section III	Exhaust System .....	4-63
Section IV	Engine Oil System .....	4-68
Section V	Ignition System .....	4-98.4
Section VI	Power Plant Controls .....	4-99
Section VII	Engine Mounts .....	4-135
Section VIII	Forward Firewall .....	4-177
Section IX	Aft Firewall .....	4-191

CHAPTER 5	ROTORS	
Section I	Main Rotor Hub and Blade Assembly . . . . .	5-2
Section II	Main Rotor Rotating Controls . . . . .	5-158
Section III	Main Rotor Tracking and Dynamic Balancing . . . . .	5-302
Section IV	Tail Rotor Hub and Blades . . . . .	5-336
Section V	Tail Rotor Pitch Change Mechanism . . . . .	5-407
Section VI	Tail Rotor Balancing . . . . .	5-470
CHAPTER 6	DRIVE TRAIN SYSTEM	
Section I	Troubleshooting . . . . .	6-2
Section II	Engine to Transmission Driveshaft. . . . .	6-19
Section III	Transmission . . . . .	6-28
Section IV	Standpipe Electrical Assembly, Torquemeter System, and Main Rotor Mast Assembly . . . . .	6-80
Section V	Freewheeling Unit . . . . .	6-167
Section VI	Tail Rotor Driveshafts . . . . .	6-218
Section VII	Tail Rotor Gearbox . . . . .	6-290
Section VIII	Oil System . . . . .	6-314
CHAPTER 7	HYDRAULIC SYSTEM	
Section I	Operational Check and Troubleshooting. . . . .	7-2
Section II	Hydraulic System Bleeding . . . . .	7-11
Section III	Hydraulic Filter Assemblies . . . . .	7-14
Section IV	Hydraulic Hoses, Lines, Fittings and Quick-Disconnects . . . . .	7-22
Section V	Pressure Switch, Manifolds and Relief Valve . . . . .	7-34
Section VI	Hydraulic Solenoid Valve . . . . .	7-46
Section VII	Hydraulic Reservoir . . . . .	7-57
Section VIII	Hydraulic Pump . . . . .	7-73
Section IX	Actuators . . . . .	7-87
CHAPTER 8	INSTRUMENT SYSTEMS	
Section I	Engine, Rotor and Transmission Instruments . . . . .	8-2
Section II	Flight Instruments . . . . .	8-37
Section III	Pitot-Static Instrument and Air Data Systems . . . . .	8-55
Section IV	Navigation Instruments . . . . .	8-87
Section V	Miscellaneous Instruments . . . . .	8-88
CHAPTER 9	ELECTRICAL SYSTEM	
Section I	Operational Checks — Electrical . . . . .	9-2
Section II	Troubleshooting — Electrical Systems . . . . .	9-382
Section III	Direct Current Power and Distribution System . . . . .	9-383
Section IV	Alternating Current Power and Distribution System . . . . .	9-506
Section V	Lighting System . . . . .	9-576
Section VI	Miscellaneous Electrical Equipment . . . . .	9-655
Section VII	Power Plant and Transmission Electrical Equipment . . . . .	9-1030
Section VIII	Avionic Cooling System . . . . .	9-1081
Section IX	Armament Electrical Equipment . . . . .	9-1114
CHAPTER 10	FUEL SYSTEM	
Section I	Fuel System . . . . .	10-2
Section II	Fuel Cell . . . . .	10-61

CHAPTER 11	FLIGHT CONTROLS	
Section I	Flight Controls Troubleshooting . . . . .	11-2
Section II	Rigging . . . . .	11-2.1
Section III	Collective Controls . . . . .	11-31
Section IV	Cyclic Control System . . . . .	11-182
Section V	Directional Controls . . . . .	11-392.11
Section VI	Component Inspection . . . . .	11-486
CHAPTER 12	UTILITY SYSTEM (Not Applicable) . . . . .	12-1
CHAPTER 13	ENVIRONMENTAL CONTROL SYSTEM	
Section I	Heating System . . . . .	13-2
Section II	Ventilating System . . . . .	13-30
CHAPTER 14	HOIST AND WINCHES (Nonapplicable) . . . . .	14-1
CHAPTER 15	AUXILIARY POWER PLANTS (Not Applicable) . . . . .	15-1
CHAPTER 16	MISSION EQUIPMENT . . . . .	16-1
Section I	Armament Operational Checks . . . . .	16-2
Section II	Armament Maintenance Procedures . . . . .	16-109
Section III	Foresight Procedures . . . . .	16-230
CHAPTER 17	EMERGENCY EQUIPMENT	
Section I	Fire Extinguisher and First Aid Kit . . . . .	17-2
CHAPTER 18	INSTALLED AVIONICS EQUIPMENT (Not Applicable)	18-1
APPENDIX A	REFERENCES . . . . .	A-1
APPENDIX B	MAINTENANCE ALLOCATION CHART (MAC) . . . . .	B-1
APPENDIX C	HELICOPTER INVENTORY MASTER GUIDE . . . . .	C-1
APPENDIX D	EXPENDABLE SUPPLIES AND MATERIALS LIST . . . . .	D-1
APPENDIX E	STORAGE OF Helicopter . . . . .	E-1
Section I	General Information . . . . .	E-1
Section II	Flyable Storage . . . . .	E-4
Section III	Short Term Storage . . . . .	E-7
Section IV	Intermediate Storage . . . . .	E-16
APPENDIX F	WIRING DIAGRAMS . . . . .	F-1
APPENDIX G	WEIGHT AND BALANCE . . . . .	G-1
Section I	General Information . . . . .	G-1
Section II	Instructions for Use of Forms and Charts . . . . .	G-2
Section III	Weighing Instructions . . . . .	G-14
APPENDIX H	ILLUSTRATED LIST OF MANUFACTURED ITEMS (AVUM) (AVIM) . . . . .	H-1
APPENDIX J	FAULT DETECTION LOCATION SYSTEM (FDLS) FAILURE CODES . . . . .	J-1

APPENDIX K	OH-58D MAINTENANCE ACTION PRECISE SYMPTOM (MAPS) . . . . .	K-1
Section I	Drive Train System (Chapter 6) . . . . .	K-1
Section II	Hydraulic System (Chapter 7) . . . . .	K-17
Section III	Instrument Systems (Chapter 8) . . . . .	K-22
Section IV	Electrical System (Chapter 9).....	K-57
Section V	Fuel System (Chapter 10) . . . . .	K-766
Section VI	Flight Controls (Chapter 11) . . . . .	K-773
■ APPENDIX L	BATTERY TESTING AND SERVICING (Not Applicable) . . . . .	L-1
■ APPENDIX M	SPECIAL PROCEDURES . . . . .	M-1
Section I	Introduction . . . . .	M-1
Section II	Equipment Requirements . . . . .	M-2
Section III	Resistance Requirements . . . . .	M-2
Section IV	Procedures . . . . .	M-2
Section V	Test . . . . .	M-29
APPENDIX N	OH-58D(I) MAINTENANCE ACTION PRECISE SYMPTOM (MAPS) . . . . .	N-1
Section I	Drive Train System (Chapter 6) . . . . .	N-1
Section II	Hydraulic System (Chapter 7) . . . . .	N-17
Section III	Instrument Systems (Chapter 8) . . . . .	N-22
Section IV	Electrical System (Chapter 9).....	N-57
Section V	Fuel System (Chapter 10) . . . . .	N-766
Section VI	Flight Controls (Chapter 11) . . . . .	N-773
Section VII	Armament (Chapter 16) . . . . .	N-781
APPENDIX P	STANDARD TORQUE VALUES . . . . .	P-1
■ APPENDIX Q	Corrosion CONTROL . . . . .	Q-1
Section I	Introduction . . . . .	Q-1
Section II	Inspection and Corrosion Prone Areas . . . . .	Q-1
Section III	Preventive Maintenance . . . . .	Q-2
Section IV	Processes and Equipment Requirements . . . . .	Q-3
Section V	Corrosion Prone Areas . . . . .	Q-3
APPENDIX R	OH-58D (SPECIAL MISSION) HELICOPTERS . . . . .	R-1
Section I	Maintenance Procedures . . . . .	R-1
Section II	Wiring Diagrams . . . . .	R-129
GLOSSARY	. . . . .	Glossary 1
INDEX	Alphabetical . . . . .	Index 1
FOLDOUTS	. . . . .	FP-1



## HOW TO USE THIS MANUAL

## 1. GENERAL.

In order to do the job right, you must be able to find the information you need. Knowing how to use this manual is very important. You should know what the manual consists of, how it is put together, and how to use it.

## 2. ORGANIZATION.

a. The entire manual is made up of a set of CHAPTERS. They are numbered in Arabic numerals (1, 2,3,4, etc.).

b. Each chapter contains information on major helicopter systems.

c. Chapters are divided into SECTIONS. Sections are numbered in Roman numerals (I, II, III, IV, etc.).

d. Each section has information you need for doing any job.

## 3. PARAGRAPHS.

a. Paragraphs are individually numbered by chapter and sequence. Illustrations are provided to make things clearer. Illustrations and index callouts apply to the text located on the same page as the illustration.

b. Paragraph numbers are assigned to each major information subject.

c. The task title (task name) is also at the top of the page.

## 4. NUMBERING.

a. Paragraphs are numbered in two parts. The first number is the CHAPTER, The second number is the PARAGRAPH number in that chapter. Each number is separated by a dash.

b. Tasks are numbered in three parts. The first number is the CHAPTER. The second number is the SECTION, and the third is the TASK number in that section. Each number is separated by a dash as shown in the example.

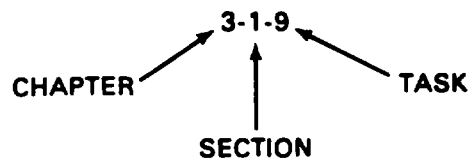

## 5. PAGE NUMBERING.

All page numbering is by chapters. Section numerals are not included in page numbers. The first number is the number of the chapter; the second number is the number of the page in that chapter. The numbers are separated by a dash as shown in the example.

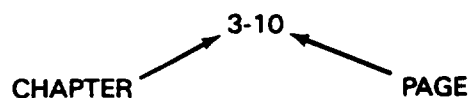

## 6. ALPHABETICAL INDEX.

a. The Alphabetical Index lists all the subjects of the manual in alphabetical order. If you know what you are looking for, it will be listed under the first letter of the first word in the title. For example: If you need information on the Tail Rotor Gearbox, look under "T", "R", or "G" in the Index.

b. The Alphabetical Index gives you the page number that has the information you need.

## 7. APPENDIXES.

a. Appendixes A through J are included in this manual to provide supplementary information required for maintenance. Each appendix contains specific instructions for its use.

b. Section III of Appendix B – Maintenance Allocation Chart – contains a list of the special tools and ground support equipment required for the OH-58D helicopter. The TOOL OR TEST EQUIPMENT REFERENCE CODE COLUMN has a number for each item on the list. This number appears as (B124) for example in identifying the particular tool or GSE in the setup table of the applicable task. Also, this number appears where applicable in Section II of Appendix B.

c. Appendix D — Expendable Supplies and Materials — contains a list of the adhesives, chemicals, etc., required to maintain the helicopter. The ITEM NUMBER column has a number for each item on the list. This number appears as (D4), for example, in identifying lockwire in the setup table of the applicable task. Also, this number appears as (D4) within the steps of the task.

## 8. GLOSSARY

a. Many words have more than one meaning. A word that has a certain meaning in every day language may have a different meaning when used for the helicopter. This is the reason for the Glossary, If you see a word in the manual and you are not sure of the meaning, check the Glossary

b. The Glossary also has a List of Abbreviations as they are used in this manual. It is always good

practice to look over the list. Make sure you know what each abbreviation stands for.

## 9. INITIAL SETUP (EXAMPLE NEXT PAGE).

The first page of each maintenance procedure in the manual is the Initial Setup. Always check the Initial Setup before starting a task on the helicopter. The Initial Setup contains information you must know. DON'T START A TASK UNTIL:

- a. You understand the task.
- b. You understand what you are to do.
- c. You know what is needed to do the work.

### NOTE

A task requiring a pilot/maintenance test pilot to perform a MOC/MTF may not necessarily list either in the Initial Setup or Follow-on Maintenance. These requirements may be covered in other referenced tasks under Follow-on Maintenance.

- d. You have the things you need.

---

11 -X-X. RIG CYCLIC CONTROLS

---

This task covers: Rigging (On Helicopter)

---

INITIAL SETUP

Applicable Configurations:

All

Tools:

- Aircraft Mechanic Tool Kit
- Rigging Bolt (B66)
- Torque Wrench, 30-150 Inch-Pounds
- Spring Scales 0-10 pounds.

Parts:

- Cotter Pin (8)
- Nut

Personnel Required:

- 66S Scout Helicopter Technical Inspector
- 67S Scout Helicopter Repairer
- Maintenance Test Pilot

References:

TM 55-1520-248-MTF

Equipment Condition:

- Forward Fairing Removed (Task 2-1-21)
- Collective Controls Rigged (Task 11 -2-1)
- CPO Collective Stick Removed (Task 11 -3-17)
- Crew Seats and Floor Panels Removed (Task 2-1-18)

General Safety Instructions:

WARNING

Ensure that no one operates control from inside of helicopter during rigging of cyclic control system. Physical injury can occur. If injury occurs, seek medical aid.

Do not drop tools in center post (vertical tunnel). Tools can Jam or damage controls. Loss of controls can result in helicopter crash and loss of lives.



GLOSSARY

ABBREVIATIONS

AC	.....	Alternating Current
ACK	.....	Acknowledge
ADF	.....	Automatic Direction Finder
ADS	.....	Air Data System
ADSS	.....	Anvis Display Symbology System
ADU	.....	Audio Distribution Unit
AGPU	.....	Aviation Ground Power Unit
ADV	.....	Advisory
AHRS (AHARS)	.....	Attitude Heading Reference System
AI	.....	Airborne Interceptor
AJ	.....	Antijamming
ALT	.....	Altitude
ALSE	.....	Aviation Life Support Equipment
AMP	.....	Ampere/Amplifier
ANVIS	.....	Advanced Night Vision Imaging System
APU	.....	Auxiliary Power Unit
ARMT	.....	Armament
ASE	.....	Aircraft Survivability Equipment
ATHS	.....	Airborne Target Handover System
ATT	.....	Attitude
AUTO	.....	Automatic
AVTR	.....	Airborne Video Tape Recorder
BATT	.....	Battery
BHOT	.....	Black Hot
BIT	.....	Built-In Test
BITE	.....	Built-In Test Equipment
BKUP	.....	Backup
BL	.....	Butt Line
BLWR	.....	Blower
BNR	.....	Burner
BRSIT	.....	Boresight
BRT	.....	Bright
°C	.....	Degrees Celsius
CARC	.....	Chemical Agent Resistant Coating
CDS	.....	Control Display System
CDSS	.....	Control Display Sub-System
CFT	.....	Captive Flight Trainer
CIPH	.....	Cipher
CKPT	.....	Cockpit
CKPTLT	.....	Cockpit Light
CLR	.....	Clear
COMSEC	.....	Communication Security
CON	.....	Contrast
CPO	.....	Copilot/Observer
DC	.....	Direct Current
DEFOG	.....	Windshield Defogger System
DES	.....	Designation
DETR	.....	Detector

ABBREVIATIONS (CONT)

IDGT	Digital
IDISENG	Disengage
IDN	Down
IDPLR	Doppler
IDRA	Data Rate Adapter
IDSC	Digital Scan Converter
IDTS	Data Transfer System
IECSP	Electronic Command Signal Programmer
IEEC	Electronic Engine Control
ELEV	Elevation
ENGA	Engage
ENG	Engine
ESC	Electronic Supervisory Control
ESNTL BUS	Essential Bus
EU	Electronics Unit
EXT	External
FCU	Fuel Control Unit
FDL	Fault Detection and Location
FM	Frequency Modulation
FOV	Field-of-View
FREQ	Frequency
FWD	Forward
GEN	Generator
GRBX	Gearbox
H	Hop
HDG.	Heading
HHM	Heading Hold Mode
HMS	HELLFIRE Missile System
HOM	Homing (FM)
HSD	Horizontal Situation Display
HSF	Hot Section Factor
HTR	Heater
HYD	Hydraulic
ICS	Inter Communication System
IEA	Interface Electronics Assembly
IFF	Identification Friend or Foe
IFM	Improved Frequency Modulation
IGN	Ignition
INIT	Initiate
INSTLT	Instrument Light
INTCOM	Intercommunication
INV	Inverter
IR	Infrared
ISP	Integrated Systems Processor
JETT	Jettison
KM	Kilometer
KPH	Kilometers Per Hour
KT S	Knots

ABBREVIATIONS (CONT)

KYBD	Keyboard
LAT	Latitude
LCF	Low Cycle Fatigue
LOAL	Lock-On After Launch
LOBL	Lock-On Before Launch
LRF/D	Laser Rangefinder/Designator
LSR	Laser
LVDT	Linear Variable Differential Transformer
MAINT	Maintenance
MAPS	Maintenance Action Precise Symptom
MCPS	Mast Mounted Central Power Supply
MCPU	Master Controller Processor Unit
MEK	Methyl-Ethyl-Ketone
MFD	Multifunction Display
MFK	Multifunction Keyboard
MLM	Multipurpose Lightweight Missile
MMS	Mast Mounted Sight
MMSS	Mast Mounted Sight Subsystem
MNL	Manual
MOC	Maintenance Operational Check
MPD	Multiparameter Display
MSP	MMS Signal Processor
MSS	Missile Sight System
MTF	Maintenance Test Flight
NVG	Night Vision Goggles
NAV	Navigation
NG	Engine Gas Producer Turbine RPM
NOE	Nap-of-the-Earth
NP	Engine Power Turbine RPM
NR	Main Rotor RPM
ODA	Optical Display Assembly
OPR	Operate
OSET	Offset
PART SP	Particle Separator
PDU	Pilot Display Unit
PLT	Pilot
POS	Position
POS LT	Position Light
PSI	Pounds Per Square Inch
PSID	Pounds Per Square Inch Differential
PWR	Power
QAD	Quick Attach-Detach
RALT	Radar Altimeter
RAST	Raster
RCPT	Receptacle
REC	Receive
RECT	Rectifier
RET	Retract

ABBREVIATIONS (CONT)

RFD	Remote Frequency Display
RKT	Rocket
RPM	Revolutions Per Minute
RST	Reset
SAM	Surface-To-Air Missile
SCAS	Stability and Control Augmentation System
SEL	Select
SEU	Sight Electronics Unit
SPRL	Spiral
STBY	Standby
SYMB	Symbology
TACFIRE	Tactical Fire Direction
TAMS	Transmission Attitude Measuring System
TCU	Thermal Control Unit
TEMP	Temperature
TGT	Turbine Gas Temperature/Target
TGT/TRQ	Turbine Gas Temperature/Torque
TIS	Thermal Indicating Sensor
T/R	Tail Rotor
TRK	Track
TVS	Television System
UTM	Universal Transverse Mercator
UWP	Universal Weapons Pylon
VAC	Volts Alternating Current
VAR	Variation
VDC	Volts Direct Current
VID	Video
VSD	Vertical Situation Display
VSI	Vertical Scale Instrument
VTR	Video Tape Recorder
VTS	Video Tracker System
VTVM	Vacuum Tube Voltmeter
WRN	Warning
WSPS	Wire Strike Protection System
XDCR	Transducer (Sensor)
XMSN	Transmission





<u>Subject</u>	<u>Para. No.</u>
<b>C (Cont)</b>	
Combat Damaged Fuel Cells . . . . .	E-32
Common Name, Names, and Designation . . . . .	1-7
Component Inspection . . . . .	11-16
Introduction . . . . .	11-17
Task List . . . . .	11-18
Components Involved in an Accident . . . . .	E-1
Conditions — Troubleshooting . . . . .	6-4
Corrosion Inspections — Preventive Maintenance Inspections . . . . .	1-58.1
Cyclic Control System . . . . .	11-10
Introduction . . . . .	11-11
Task List . . . . .	11-12

**D**

Damaged, Cannibalized or Failed Engine Preservation Procedure— Intermediate Storage . . . . .	E-45
Definitions—Introduction . . . . .	M-2
Definition of the Maintenance Allocation Chart . . . . .	B-2
Definitions—Special Procedures (Introduction) . . . . .	M-2
Depreservation After Flyable Storage . . . . .	E-12
Depreservation After Intermediate Storage . . . . .	E-46
Depreservation After Short Term Storage . . . . .	E-26
Description— Flyable Storage . . . . .	E-6
Battery Testing and Servicing . . . . .	L-5
Equipment List . . . . .	F-7
Intermediate Storage . . . . .	E-27
Short Term Storage . . . . .	E-13
Destruction of Army Material to Prevent Enemy Use . . . . .	1-4
Differences Between Models . . . . .	1-12
Direct Current Power and Distribution System . . . . .	9-7
Introduction . . . . .	9-8
Task List . . . . .	9-9
Directional Controls . . . . .	11-13
Introduction . . . . .	11-14
Task List . . . . .	11-15

<u>Subject</u>	<u>Para. No.</u>
<b>D (Cont)</b>	
Doppler Radar Bit . . . . .	J-7
Drive Train System . . . . .	6-1
Principles of Operation . . . . .	1-29
Task List . . . . .	6-5
Troubleshooting . . . . .	6-2
DTS Bit (OH-58D(I) ) . . . . .	J-20
Dynamic Balancing — Main Rotor . . . . .	5-10

**E**

Electrical Bonding Classes— Introduction . . . . .	M-3
Electrical Bonding Methods — Procedures . . . . .	M-7
Electrical Equipment— Miscellaneous . . . . .	9-18
Electrical Equipment—Tools . . . . .	M-4
Electrical Operational Checks . . . . .	9-4
Electrical System . . . . .	9-1, E-34
Alternating Current Power and Distribution System . . . . .	9-10
Armament Electrical Equipment . . . . .	9-25
Avionic Cooling System . . . . .	9-22
Direct Power and Distribution System . . . . .	9-7
Equipment Data . . . . .	1-20
Introduction— Alternating Current Power and Distribution System . . . . .	9-11
Introduction—Armament Electrical Equipment . . . . .	9-26
Introduction—Direct Power and Distribution System . . . . .	9-8
Introduction — Electrical System . . . . .	9-6
Introduction — Lighting System . . . . .	9-14
Introduction—Miscellaneous Electrical Equipment . . . . .	9-17
Introduction —Operational Checks . . . . .	9-3
Introduction — Power Plant and Transmission Electrical Equipment . . . . .	9-20
Lighting System . . . . .	9-13
Miscellaneous Electrical Equipment . . . . .	9-16
Operational Checks — Electrical . . . . .	9-2

<u>Subject</u>	<u>Para. No.</u>	<u>Subject</u>	<u>Para. No.</u>
<b>E (Cont)</b>		<b>E (Cont)</b>	
Powerplant and Transmission		Equipment Characteristics,	
Electrical Equipment . . . . .	9-19	Capabilities, and Features . . . . .	1-10
Task List . . . . .	9-4	Equipment Configuration . . . . .	1-21
Task List — Alternating Current		Equipment Data . . . . .	1-13
Power and Distribution System . . . . .	9-12	Electrical System . . . . .	1-20
Task List — Armament		Engine . . . . .	1-17
Electrical Equipment . . . . .	9-27	Engine Oil System . . . . .	1-16
Task List — Avionic Cooling		Fuel System . . . . .	1-14
System . . . . .	9-24	Hydraulic System . . . . .	1-15
Task List — Direct Current		Main Transmission . . . . .	1-18
Power and Distribution System . . . . .	9-9	Tail Rotor Gearbox . . . . .	1-19
Task List — Lighting System . . . . .	9-15	Equipment	
Task List — Miscellaneous		Armament Electrical . . . . .	9-25
Electrical Equipment . . . . .	9-18	Avionics . . . . .	E-21, E-39
Task List — Power Plant and		Electrical . . . . .	M-4
Transmission Electrical		Emergency . . . . .	17-1, E-40
Equipment . . . . .	9-21	Equipment List . . . . .	F-6
Troubleshooting — Electrical		Miscellaneous Electrical . . . . .	9-16
System . . . . .	9-5	Mission (Armament) . . . . .	1-38, 16-1
Electrical Systems — Principles of		Exhaust System . . . . .	4-8
Operation . . . . .	1-32	Introduction . . . . .	4-9
Emergency Equipment . . . . .	17-1, E-40	Task List . . . . .	4-10
Principles of Operation . . . . .	1-40	Expendable Supplies and	
Engine — Equipment Data . . . . .	1-17	Materials List . . . . .	D-1
Intermediate Storage . . . . .	E-30	Explanation of Columns . . . . .	D-2
Short Term Storage . . . . .	E-16		
Engine Assembly . . . . .	4-2	<b>F</b>	
Introduction . . . . .	4-3	FDLS Failure Codes . . . . .	J-1
Task List . . . . .	4-4	Filter Assemblies — Hydraulic . . . . .	7-11
Engine Mounts . . . . .	4-18	Fire Extinguisher and First Aid Kit . . . . .	17-2
Introduction . . . . .	4-19	Introduction . . . . .	17-3
Task List . . . . .	4-20	Task List . . . . .	17-4
Engine Oil System . . . . .	4-11	Firewall	
Equipment Data . . . . .	1-16	Aft . . . . .	4-24
Introduction . . . . .	4-12	Forward . . . . .	4-21
Task List . . . . .	4-13	Fittings — Hydraulic . . . . .	7-14
Engine, Rotor, and Transmission		Flight Controls . . . . .	11-1
Instruments . . . . .	8-2	Collective . . . . .	11-7
Introduction . . . . .	8-3	Cyclic . . . . .	11-10
Task List . . . . .	8-5	Directional . . . . .	11-13
Troubleshooting Engine, Rotor,		Introduction . . . . .	11-3
and Transmission Instruments . . . . .	8-4	Principles of Operation . . . . .	1-34
Engine-to-Transmission Driveshaft . . . . .	6-6	Troubleshooting . . . . .	11-2
Introduction . . . . .	6-7	Flight Instruments . . . . .	8-6
Task List . . . . .	6-8	Introduction . . . . .	8-7
Environmental Control Systems . . . . .	13-1	Task List . . . . .	8-9
Principles of Operation . . . . .	1-36		

<u>Subject</u>	<u>Para. No.</u>
<b>F (Cont)</b>	
Troubleshooting Flight Instruments .....	8-8
Flight Safety Parts .....	1-60
Flight Safety Parts Program .....	1-61
Flyable Storage	
Airframe .....	E-10
Depreservation After Flyable Storage .....	E-12
Description .....	E-6
Fuel System, .....	E-9
Hydraulic System .....	E-8
Main Rotor Blades .....	E-10.1
Maintenance of Preservation During Flyable Storage .....	E-11
Mast Mounted Sight .....	E-10.2
Power Train .....	E-7
Foldout Wiring Diagram Index .....	F-9
Forms .....	G-6
Forward Firewall .....	4-21
Introduction .....	4-22
Task List .....	4-23
Freewheeling Unit .....	6-15
Introduction .....	6-16
Task List .....	6-17
Fuel Cell .....	10-6
Combat Damaged .....	E-32
Introduction .....	10-7
Task List .....	10-8
Fuel Control Bit .....	J-5
Fuel System .....	10-1
Equipment Data .....	1-14
Flyable Storage .....	E-9
Intermediate Storage .....	E-31
Principles of Operation .....	1-33
Short Term Storage .....	E-17
Fuel System Components .....	10-2
Introduction .....	10-3
Task List .....	10-5
Troubleshooting .....	10-4
Functional Description .....	1-23
Functional Groupings .....	B-5
Maintenance Categories and Work Times (Column 4) .....	B-8
Maintenance Function (Column 3) .....	B-7
Remarks (Column 6 and Section IV) .....	B-10
System Group Number and Description (Columns 1 and 2) .....	B-6

<u>Subject</u>	<u>Para. No.</u>
<b>F (Cont)</b>	
Tools and Test Equipment (Column 5 and Section III) .....	B-9
Fuselage .....	2-2
Introduction .....	2-3
Task List .....	2-4

**G**

General Information—Preventive Maintenance Inspections .....		1-56
Ground Handling and Jacking .....		1-46
introduction .....		1-47
Special Requirements .....		1-48
Task List .....		1-49

**H**

Heating System .....		13-2
introduction .....		13-3
Task List .....		13-4
Helicopter Inventory Master Guide .....		C-1
Introduction .....		C-1
Inventoriable items .....		C-3
Periods of Inventory .....		C-4
Security .....		C-2
HF Radio Bit .....		J-16
Hoisting and Sling Loading .....		1-53
Introduction .....		1-54
Task List .....		1-55
Hydraulic Actuators .....		7-27
Introduction .....		7-28
Task List .....		7-29
Hydraulic Filter Assemblies .....		7-9
Introduction .....		7-10
Task List .....		7-11
Hydraulic Hoses, Lines, Fittings, and Quick-Disconnects .....		7-12
Introduction .....		7-13
Task List .....		7-14
Hydraulic Pump .....		7-24
Introduction .....		7-25
Task List .....		7-26
Hydraulic Reservoir .....		7-21
Introduction .....		7-22
Task List .....		7-23
Hydraulic Solenoid Valve .....		7-18
Introduction .....		7-19

<u>Subject</u>	<u>Para. No.</u>	<u>Subject</u>	<u>Para. No.</u>
<b>H (Cont)</b>		<b>I (Cont)</b>	
Task List . . . . .	7-20	Damaged, Cannibalized or Failed Engine Preservation Procedure.. . . . .	E-45
Hydraulic System . . . . .	7-1,7-2	Depreservation After Intermediate Storage . . . . .	E-46
Equipment Data . . . . .	1-15	Description . . . . .	E-27
Flyable Storage . . . . .	E-8	Electrical System . . . . .	E-34
Intermediate Storage . . . . .	E-33	Emergency Equipment . . . . .	E-40
Introduction . . . . .	7-3	Engine . . . . .	E-30
Principles of Operation . . . . .	1-30	Fuel System . . . . .	E-31
Pump . . . . .	7-26	Hydraulic System . . . . .	E-33
Reservoir . . . . .	7-23	Inspection Prior to Storage . . . . .	E-28
Short Term Storage . . . . .	E-18	Instruments . . . . .	E-38
Solenoid Valve . . . . .	7-20	Landing Gear . . . . .	E-41
Task List . . . . .	7-5	Maintenance of Preservation . . . . .	E-43
Troubleshooting . . . . .	7-4	Main Rotor Blades . . . . .	E-35
Hydraulic System Bleeding . . . . .	7-6	Main Rotor Hub and Mast Assembly . . . . .	E-36
Introduction . . . . .	7-7	Power Train System . . . . .	E-29
Task List . . . . .	7-8	Tail Rotor Group . . . . .	E-37
<b>I</b>		Introduction . . . . .	1-1
IFF Bit . . . . .	J-18	Actuators . . . . .	7-28
IFM Amplifier Bit . . . . .	J-14	Aft Firewall . . . . .	4-25
Ignition System . . . . .	4-14	Air Induction . . . . .	4-6
Inspection of Stored Helicopters . . . . .	E-5	Alternating Current Power and Distribution System . . . . .	9-10
Inspection Prior to Storage — Intermediate Storage . . . . .	E-28	Armament Electrical Equipment . . . . .	9-25
Inspection Prior to Storage — Short Term Storage . . . . .	E-14	Armament Maintenance Procedures . . . . .	16-6
Instrument Systems . . . . .	8-1	Armament Operational Checks . . . . .	16-3
Principles of Operation . . . . .	1-31	Avionic Cooling System . . . . .	9-23
Instruments — Intermediate Storage . . . . .	E-38	Boresight Procedures . . . . .	16-9
Engine . . . . .	8-2	Collective Controls . . . . .	11-8
Flight . . . . .	8-6	Component Inspection . . . . .	11-17
Rotor . . . . .	8-2	Cyclic Control System . . . . .	11-11
System . . . . .	8-1	Definitions . . . . .	M-2
Transmission . . . . .	8-2	Direct Current Power and Distribution System . . . . .	9-8
Instruments — Short Term Storage . . . . .	E-20	Directional Controls . . . . .	11-14
Intended Use of Bonding — Introduction . . . . .	M-1	Electrical Bonding Classes . . . . .	M-3
Intermediate Storage Accident Engines — Preservation . . . . .	E-44	Engine Assembly . . . . .	4-3
Airframe . . . . .	E-42	Engine Mounts . . . . .	4-19
Avionic Equipment . . . . .	E-39	Engine Oil System . . . . .	4-12
Combat Damaged Fuel Cells . . . . .	E-32	Engine, Rotor, and Transmission Instruments . . . . .	8-3
		Engine-to-Transmission Driveshaft . . . . .	6-7
		Exhaust System . . . . .	4-9

<u>Subject</u>	<u>Para. No.</u>
I (Cont)	
Fire Extinguisher and First Aid Kit . . . . .	17-3
Flight Controls Troubleshooting . . . . .	11-3
Flight Instruments . . . . .	8-7
Forward Firewall . . . . .	4-22
Freewheeling Unit . . . . .	6-16
Fuel Cell . . . . .	10-7
Fuel System Components . . . . .	10-3
Fuselage . . . . .	2-3
Ground Handling and Jacking . . . . .	1-47
Heating System . . . . .	13-3
Helicopter Inventory Master Guide . . . . .	C-1
Hoisting and Sling Loading . . . . .	1-54
Hydraulic Filter Assemblies . . . . .	7-10
Hydraulic Hoses, Lines, Fittings, and Quick-Disconnects . . . . .	7-13
Hydraulic Pump . . . . .	7-25
Hydraulic Reservoir . . . . .	7-22
Hydraulic Solenoid Valve . . . . .	7-19
Hydraulic System . . . . .	7-3
Hydraulic System Bleeding . . . . .	7-7
intended Use of Bonding . . . . .	M-1
Lighting System . . . . .	9-13
Main Rotor Rotating Controls. . . . .	5-6
Main Rotor Tracking and Dynamic Balancing . . . . .	5-9
Miscellaneous Electrical Equipment . . . . .	9-16
Miscellaneous Instruments . . . . .	8-16
Mooring . . . . .	1-51
Oil System . . . . .	6-25
Operational Checks — Electrical . . . . .	9-2
Pitot-Static instrument and Air Data System . . . . .	8-11
Power Plant and Transmission Electrical Equipment . . . . .	9-19
Power Plant Controls . . . . .	4-16
Pressure Switch, Manifolds, and Relief Valve . . . . .	7-16
Pylon . . . . .	2-9
Rigging . . . . .	11-5
Rotor Hub and Blade Assembly . . . . .	5-3
Selection and Use of Torque Wrench . . . . .	P-6
Servicing . . . . .	1-42
Standard Torque Values . . . . .	P-2

<u>Subject</u>	<u>Para. No.</u>
I (Cont)	
Standpipe Electrical Assembly, Torquemeter System, and Main Rotor Mast Assembly . . . . .	6-13
Tailboom . . . . .	2-6
Tail Rotor Balancing . . . . .	5-18
Tail Rotor Driveshafts . . . . .	6-19
Tail Rotor Gearbox . . . . .	6-22
Tail Rotor Hub and Blades . . . . .	5-12
Tail Rotor Pitch Change Mechanism . . . . .	5-15
Transmission . . . . .	6-10
Troubleshooting — Drive Train System . . . . .	6-3
Troubleshooting— Electrical System . . . . .	9-6
Ventilating System . . . . .	13-6
Inventoriable items — Helicopter Inventory Master Guide . . . . .	C-3
ISP Bit (OH58D(I) ) . . . . .	J-19

**L**

Landing Gear . . . . .	3-2
Intermediate Storage . . . . .	E-41
Introduction . . . . .	3-3
Principles of Operation . . . . .	1-26
Task List . . . . .	3-4
Last Flight Recall (OH58D) . . . . .	J-3
Last Flight Recall (OH58D(I)) . . . . .	J-3.1
Lighting System . . . . .	9-13
Introduction . . . . .	9-14
Task List . . . . .	9-15
Loading Data . . . . .	G-11
Location and Description of Major Components . . . . .	1-11
Lubrication . . . . .	1-45

**M**

Main Rotor Blades — Flyable Storage . . . . .	E-10.1
Main Rotor Blades — Intermediate Storage . . . . .	E-35
Main Rotor Hub and Mast Assembly — Intermediate Storage . . . . .	E-36
Main Rotor Rotating Controls . . . . .	5-5
Introduction . . . . .	5-6

<u>Subject</u>	<u>Para. No.</u>	<u>Subject</u>	<u>Para. No.</u>
<b>M (Cont)</b>		<b>M (Cont)</b>	
Task List .....	5-7	MUX Bus Status .....	J-22
Main Rotor Tracking and Dynamic Balancing .....	5-8	<b>N</b>	
Introduction .....	5-9		
Task List .....	5-10	Navigation Instruments .....	8-14
Main Transmission — Equipment Data .....	1-18	<b>O</b>	
Maintenance Allocation Chart .....	B-1		
Definition of the Maintenance Allocation Chart .....	B-2	Oil System .....	6-24
Maintenance Functions .....	B-4	Engine .....	4-11
Use of the Maintenance Allocation Chart (Section 3) .....	B-3	Introduction .....	6-25
Maintenance Allocation Chart Remarks .....	B-12	Task List .....	6-26
Maintenance Categories and Work Times (Column 4) .....	B-8	Operational Checks — Electrical .....	9-2
Maintenance Forms and Records .....	1-3	Introduction .....	9-3
Maintenance Function (Column 3) .....	B-7	Task List .....	9-4
Maintenance Functions .....	B-4	Overhaul and Retirement Schedule .....	1-59
Maintenance of Preservation — Short Term Storage .....	E-24	<b>P</b>	
Intermediate Storage .....	E-43		
Maintenance of Preservation During Flyable Storage .....	E-n	Periods of Inventory .....	C-4
Maintenance Procedures— Armament .....	16-5	Pitot-Static instrument and Air Data System .....	8-10
Mast Mounted Sight—Flyable Storage .....	E-10.2	Introduction .....	8-11
Mast Torque Bit .....	J-12	Task List .....	8-13
Miscellaneous Electrical Equipment .....	9-16	Troubleshooting .....	8-12
Introduction .....	9-17	Power Plant .....	4-1
Task List .....	9-18	Principles of Operation .....	1-27
Miscellaneous instruments .....	8-15	Power Plant and Transmission Electrical Equipment .....	9-19
Introduction .....	8-16	Introduction .....	9-20
Task List .....	8-18	Task List .....	9-21
Troubleshooting .....	8-17	Power Plant Controls .....	4-15
Mission Equipment .....	16-1	Introduction .....	4-16
Mission Equipment (Armament)— Principles of Operation .....	1-38	Task List .....	4-17
Mission Equipment (Avionics)— Principles of Operation .....	1-37	Power Train — Flyable Storage .....	E-7
MMS Bit .....	J-9	Power Train System— Intermediate Storage .....	E-29
Mooring .....	1-50	Power Train System—Short Term Storage .....	E-15
Introduction .....	1-51	Preparation for Storage or Shipment .....	1-5
Task List .....	1-52	Pressure Switch, Manifolds, and Relief Valve .....	7-15
		Introduction .....	7-16
		Task List .....	7-17

<u>Subject</u>	<u>Para. No.</u>	<u>Subject</u>	<u>Para. No.</u>
<b>P (Cont)</b>		<b>R (Cont)</b>	
Principles of Operation . . . . .	1-24	Reporting Equipment Improvement	
Airframe . . . . .	1-25	Recommendations (EIR) . . . . .	1-8
Analog and Digital Instruments . . . . .	1-39	Requirements—Storage of	
Drive Train System . . . . .	1-29	Helicopter . . . . .	E-2
Electrical Systems . . . . .	1-32	Resistance of Electrical Bonds—	
Emergency Equipment . . . . .	1-40	Resistance Requirements . . . . .	M-5
Environmental Control Systems . . . . .	1-36	Responsibility — Weight and	
Flight Controls . . . . .	1-34	Balance . . . . .	G-3
Fuel System . . . . .	1-33	Rigging . . . . .	11-4
Hydraulic System . . . . .	1-30	Introduction . . . . .	11-5
Instrument System . . . . .	1-31	Task List . . . . .	11-6
Landing Gear . . . . .	1-26	Rotor Hub and Blade Assembly . . . . .	5-2
Mission Equipment (Armament).. . . . .	1-38	Introduction . . . . .	5-3
Mission Equipment (Avionics) . . . . .	1-37	Task List . . . . .	5-4
Power Plant . . . . .	1-27	Rotor System — Short Term	
Rotors . . . . .	1-28	Storage . . . . .	E-19
Utility Systems . . . . .	1-35	Rotors . . . . .	5-1
Procedures Common to Ail		Principles of Operation . . . . .	1-28
Categories of Storage . . . . .	E-4	<b>S</b>	
Purpose of Electrical Test . . . . .	L-2	Safety, Care, and Handling . . . . .	1-22
Pylon . . . . .	2-8	SCAS Bit . . . . .	J-17
Introduction . . . . .	2-9	Scope . . . . .	1-2
Task List . . . . .	2-10	Battery Testing and Servicing . . . . .	L-1
<b>Q</b>		Expendable Supplies and	
Quality Assurance/Quality Control		Materials List . . . . .	D-1
(QA/QC) . . . . .	1-6	Weight and Balance . . . . .	G-1
<b>R</b>		Sealing— Special Procedures	
Radar Altimeter Bit, . . . . .	J-10	(Procedures) . . . . .	M-8
Radio Bit . . . . .	J-15	Security— Helicopter Inventory	
Recommended Installation Torque		Master Guide . . . . .	C-2
Range . . . . .	P-4	Selection and Use of Torque	
Record of Weight and Balance		Wrench . . . . .	P-6
Personnel, DD Form 365 . . . . .	G-7	Servicing . . . . .	1-41
Refinishing —Special Procedures		Approved Servicing Tables . . . . .	1-43
(Procedures) . . . . .	M-9	Introduction . . . . .	1-42
Remarks (Column 6 and Section		Task List . . . . .	1-44
IV) . . . . .	B-8	Short Term Storage	
		Airframe . . . . .	E-23
		Avionics Equipment . . . . .	E-21
		Battery . . . . .	E-25
		Depreservation After Short Term	
		Storage . . . . .	E-26
		Description . . . . .	E-13
		Engine . . . . .	E-16
		Fuel System . . . . .	E-17
		Hydraulic System . . . . .	E-18



<u>Subject</u>	<u>Para. No.</u>	<u>Subject</u>	<u>Para. No.</u>
<b>S (Cont)</b>		<b>S (Cont)</b>	
Inspection Prior to Storage . . . . .	E-14	Surface Preparation-Procedures . . . . .	M-6
Instruments . . . . .	E-20	Symbols — Wiring Diagrams . . . . .	F-5
Landing Gear . . . . .	E-22	System Group Number and Description (Columns 1 and ) . . . . .	B-6
Maintenance of Preservation . . . . .	E-24		
Power Train System . . . . .	E-15	T	
Rotor System . . . . .	E-19		
Sling Loading . . . . .	1-53	Tailboom . . . . .	2-5
Special inspection . . . . .	1-58	Introduction . . . . .	2-6
Special Procedures		Task List . . . . .	2-7
Bond Resistance . . . . .	M-10	Tail Rotor Balancing . . . . .	5-17
Definitions . . . . .	M-2	Introduction . . . . .	5-18
Electrical Bonding Classes . . . . .	M-3	Task List . . . . .	5-19
Electrical Bonding Methods . . . . .	M-7	Tail Rotor Driveshaft . . . . .	6-18
intended Use of Bonding . . . . .	M-1	Introduction . . . . .	6-19
Refinishing . . . . .	M-9	Task List . . . . .	6-20
Resistance of Electrical Bonds . . . . .	M-5	Tail Rotor Gearbox . . . . .	6-21
Sealing . . . . .	M-8	Equipment Data . . . . .	1-19
Surface Preparation . . . . .	M-6	Introduction . . . . .	6-22
Test of Bond . . . . .	M-11	Task List . . . . .	6-23
Tool . . . . .	M-4	Tail Rotor Group . . . . .	E-37
Specified Requirements . . . . .	1-48	Tail Rotor Hub and Blades... . . . .	5-11
Ground Handling and Jacking . . . . .	1-46	Introduction . . . . .	5-12
Standard Torque Values		Task List . . . . .	5-13
Introduction . . . . .	P-1	Tail Rotor Pitch Change Mechanism . . . . .	5-14
Recommended Installation		Introduction . . . . .	5-15
Torque Range . . . . .	P-4	Task List . . . . .	5-16
Selection and Use of Torque		Task List	
Wrench . . . . .	P-6	Actuators — Hydraulic . . . . .	7-29
Special Torques . . . . .	P-5	Aft Firewall . . . . .	4-26
Torque . . . . .	P-3	Air Induction . . . . .	4-7
Torque Values . . . . .	P-2	Alternating Current Power and Distribution System . . . . .	9-12
Standards of Serviceability . . . . .	1-57	Armament Electrical Equipment . . . . .	9-27
Standpipe Electrical Assembly, Torquemeter System, and Main Rotor Mast Assembly . . . . .	6-12	Armament Maintenance Procedures . . . . .	16-7
Introduction . . . . .	6-13	Armament Operational Checks . . . . .	16-4
Task List . . . . .	6-14	Avionic Cooling System . . . . .	9-24
Storage of Helicopter		Battery Testing and Servicing . . . . .	L-5
Categories of Storage . . . . .	E-3	Boresight Procedures . . . . .	16-10
Components Involved in an Accident . . . . .	E-1	Collective Controls . . . . .	11-9
inspection of Stored Helicopters . . . . .	E-5	Component Inspection . . . . .	11-18
Requirements . . . . .	E-2	Cyclic Control System . . . . .	11-12
		Direct Current Power and Distribution System . . . . .	9-9
		Directional Controls . . . . .	11-15
		Engine Assembly . . . . .	4-4

<u>Subject</u>	<u>Para. No.</u>	<u>Subject</u>	<u>Para. No.</u>
<b>T (Cont)</b>		<b>T (Cont)</b>	
Engine Mounts . . . . .	4-20	Standpipe Electrical Assembly, Torquemeter System, and Main Rotor Mast Assembly . . . . .	6-14
Engine Oil System . . . . .	4-13	Tailboom . . . . .	2-7
Engine, Rotor, and Transmission Instruments . . . . .	8-5	Tail Rotor Balancing . . . . .	5-19
Engine-to-Transmission Driveshaft . . . . .	6-8	Tail Rotor Driveshafts . . . . .	6-20
Exhaust System . . . . .	4-10	Tail Rotor Gearbox . . . . .	6-23
Fire Extinguisher and First Aid Kit . . . . .	17-4	Tail Rotor Hub and Blades . . . . .	5-13
Flight Instruments . . . . .	8-9	Tail Rotor Pitch Change Mechanism . . . . .	5-16
Forward Firewall . . . . .	4-23	Transmission . . . . .	6-11
Freewheeling Unit . . . . .	6-17	Troubleshooting . . . . .	6-5
Fuel Cell . . . . .	10-8	Troubleshooting Miscellaneous Instruments . . . . .	8-18
Fuel System Components . . . . .	10-5	Ventilating System . . . . .	13-7
Fuselage . . . . .	2-4	Test of Bond— Special Procedures (Test) . . . . .	M-11
Ground Handling and Jacking . . . . .	1-49	Tool and Test Equipment Requirements . . . . .	B-11
Heating System . . . . .	13-4	Tools — Electrical Equipment . . . . .	M-4
Hoisting and Sling Loading . . . . .	1-55	Tools and Test Equipment (Column 5 and Section III) . . . . .	B-9
Hydraulic Filter Assemblies . . . . .	7-11	Torque . . . . .	P-3
Hydraulic Hoses, Lines, Fittings, and Quick-Disconnects . . . . .	7-14	Torque Values . . . . .	P-2
Hydraulic Pump . . . . .	7-26	Introduction . . . . .	P-1
Hydraulic Reservoir . . . . .	7-23	Transmission . . . . .	6-9
Hydraulic Solenoid Valve . . . . .	7-20	Introduction . . . . .	6-10
Hydraulic System . . . . .	7-5	Task List . . . . .	6-11
Hydraulic System Bleeding . . . . .	7-8	Transmission Attitude Measurement Subsystem (TAMS) Bit . . . . .	J-11
Lighting System . . . . .	9-15	Troubleshooting . . . . .	6-2
Main Rotor Rotating Controls . . . . .	5-7	Conditions . . . . .	6-4
Main Rotor Tracking and Dynamic Balancing . . . . .	5-10	Drive Train System . . . . .	6-2
Miscellaneous Electrical Equipment . . . . .	9-18	Electrical System . . . . .	9-5
Miscellaneous Instruments . . . . .	8-18	Engine, Rotor, and Transmission Instruments . . . . .	8-4
Mooring . . . . .	1-52	Flight Instruments . . . . .	8-8
Oil System . . . . .	6-26	Hydraulic System . . . . .	7-4
Operational Checks — Electrical . . . . .	9-4	Introduction . . . . .	6-3
Pitot-Static Instrument and Air Data System . . . . .	8-13	Miscellaneous Instruments . . . . .	8-17
Power Plant and Transmission Electrical Equipment . . . . .	9-21	Pitot-Static instruments and Air Data System . . . . .	8-12
Power Plant Controls . . . . .	4-17	Task List . . . . .	6-5
Pressure Switch, Manifolds, and Relief Valve . . . . .	7-17		
Pylon . . . . .	2-10		
Rigging . . . . .	11-6		
Rotor Hub and Blade Assembly . . . . .	5-4		
Servicing . . . . .	1-44		

<b>Subject</b>	<b><u>Para. No.</u></b>	<b>Subject</b>	<b><u>Para. No.</u></b>
<b>T (Cont)</b>		<b>W (Cont)</b>	
Troubleshooting — Electrical System .....	9-5	Basic Weight and Balance Record, DD Form 365-3 .....	G-10
Introduction .....	9-6	Basic Weight Checklist DD Form 365-1 .....	G-8
<b>U</b>		Forms .....	G-6
Use of the Maintenance Allocation Chart (Section II) .....	B-2	Loading Data .....	G-11
Utility Systems — Principles of Operation .....	1-35	Preliminary Weighing Instructions .....	G-14
<b>V</b>		Record of Weight and Balance Personnel, DD Form 365 .....	G-7
Ventilating System .....	13-5	Responsibility .....	G-3
Introduction .....	13-6	Scope .....	G-1
Task List .....	13-7	Weight and Balance Clearance Form F, DD Form 365-4 .....	G-12
VTR Bit(OH-58D(I) ) .....	J-2I	Weight and Balance Data .....	G-2
<b>W</b>		Weight Definition .....	G-4
Warnings, Cautions, and Notes .....	L-4	Weighing Equipment .....	G-15
Warranty Information .....	1-9	Weight/Balance and Load Data .....	G-5
Weight and Balance		Wire Identifications .....	F-3
Aircraft Weighings .....	G-13	Wiring Data .....	F-2
Airplane Weighing Record, DD Form 365-2 .....	G-9	Wiring Diagrams.. .....	F-1
		Abbreviation .....	F-4
		Equipment List .....	F-6
		Foldout Wiring Diagram Index .....	F-9
		Symbols .....	F-5
		Wire Identification .....	F-3
		Wire Repair and Replacement .....	F-8
		Wiring Data .....	F-2



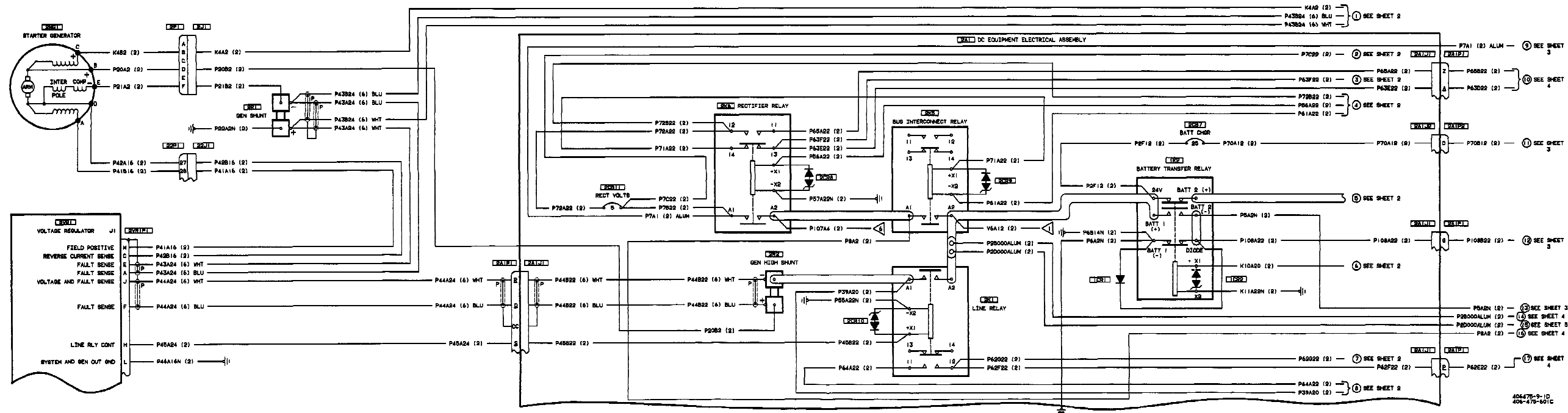

Figure FO-1. DC Power Wiring Diagram (Sheet 1 of 6)

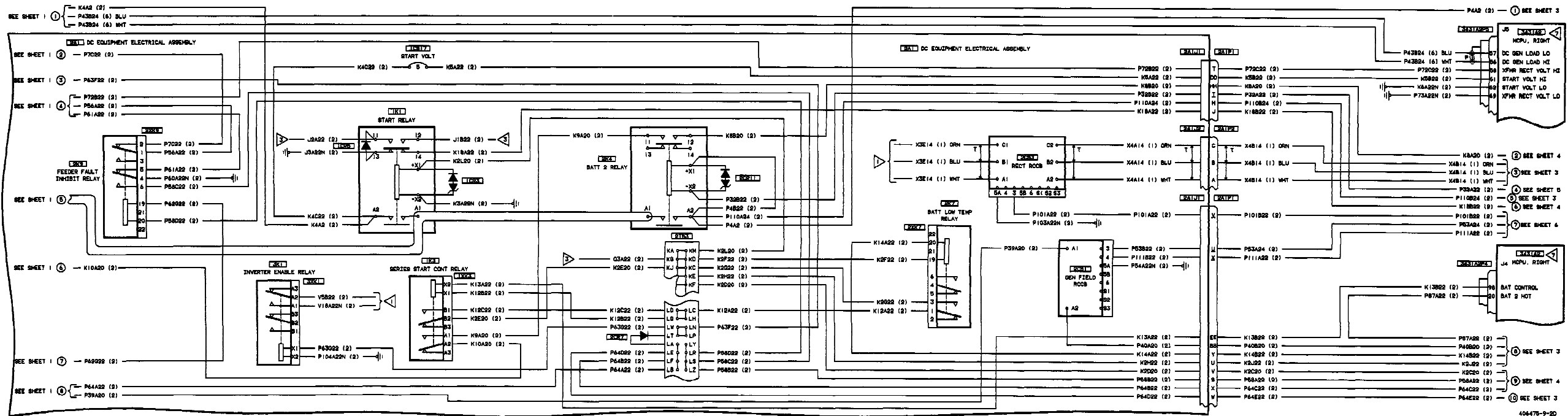

Figure FO-1. DC Power Wiring Diagram (Sheet 2 of 6)

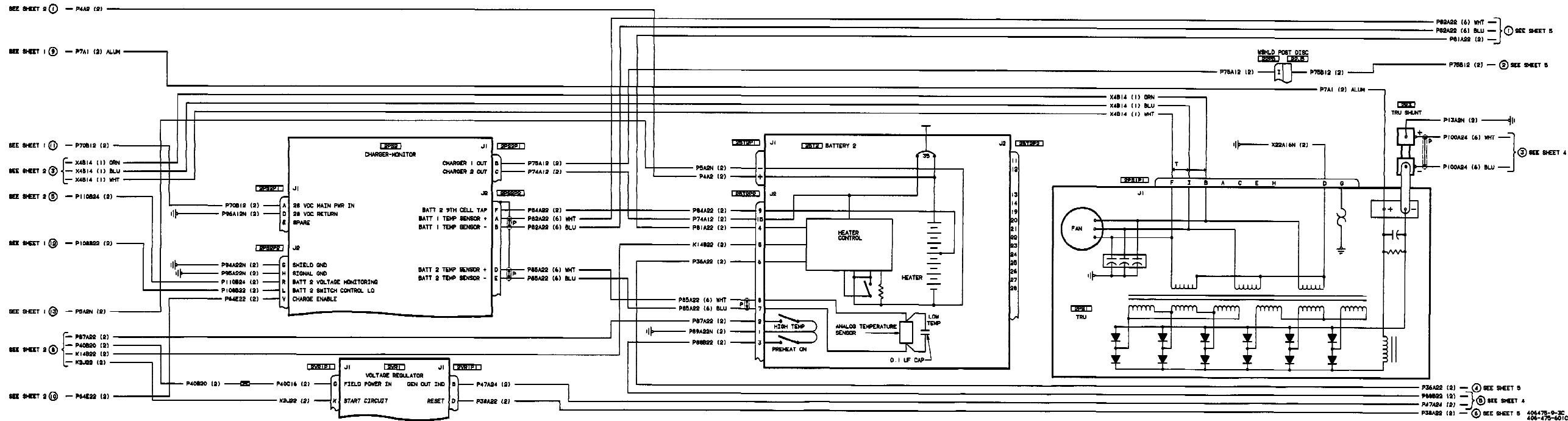

Figure FO-1. DC Power Wiring Diagram (Sheet 3 of 6)

404478-0-2C  
404-478-601C

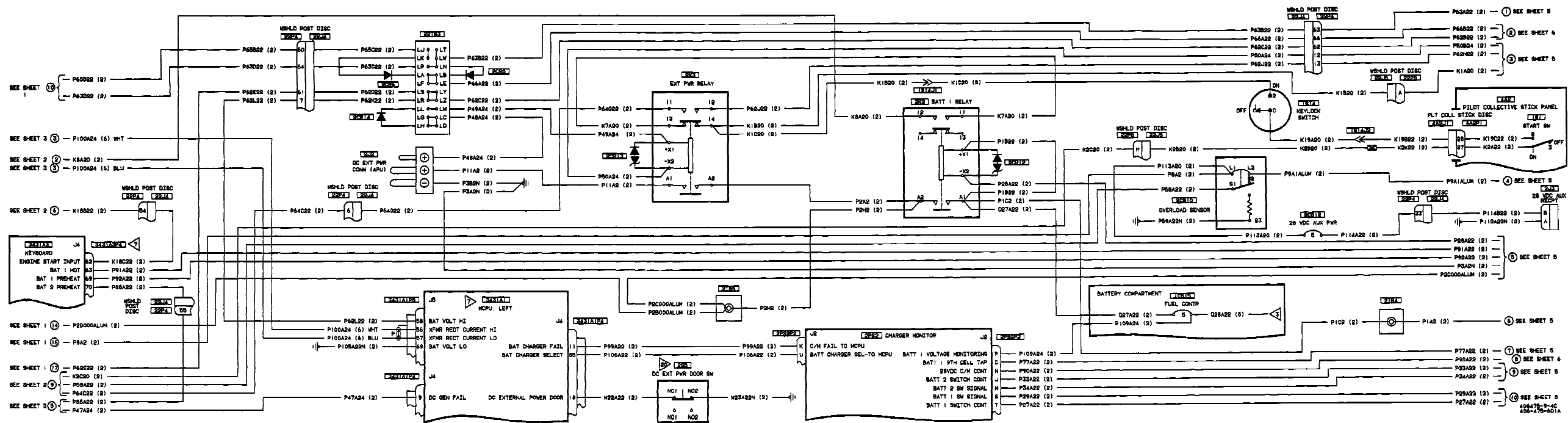

Figure FO-1. DC Power Wiring Diagram (Sheet 4 of 6)



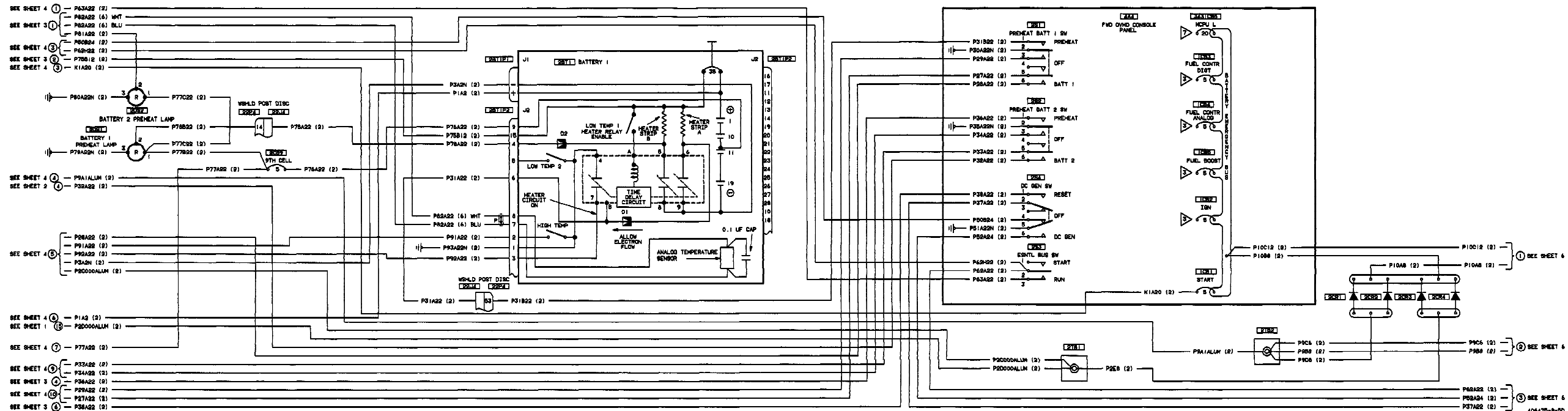
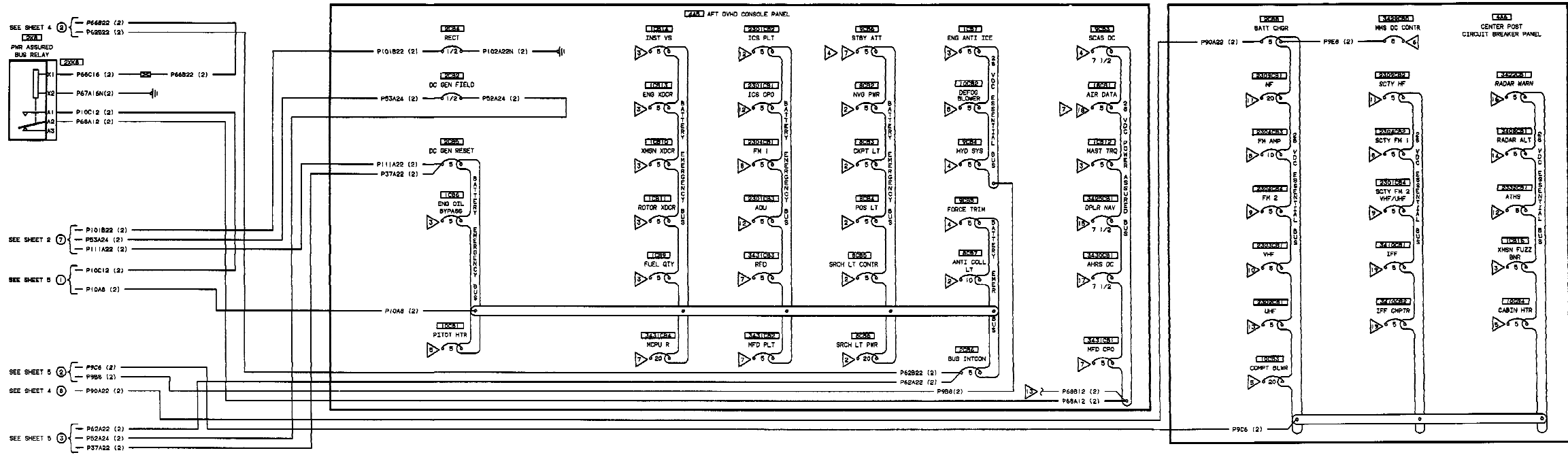

Figure FO-1. DC Power Wiring Diagram (Sheet 5 of 6)



- NOTES
- 1. REFER TO A/D POWER SYSTEM WIRING DIAGRAM.
  - 2. REFER TO LIGHTING SYSTEM WIRING DIAGRAM.
  - 3. REFER TO POWER PLANT AND TRANSMISSION SYSTEM WIRING DIAGRAM.
  - 4. REFER TO SCAS HYDRAULIC AND STANDBY ATTITUDE GYRO SYSTEM WIRING DIAGRAM.
  - 5. REFER TO ENVIRONMENTAL SYSTEM WIRING DIAGRAM.
  - 6. REFER TO MMS SYSTEM WIRING DIAGRAM.
  - 7. REFER TO ODS SYSTEM WIRING DIAGRAM.
  - 8. REFER TO NO. 1 VHF FM WIRING DIAGRAM TM 11-1520-248-23.
  - 9. REFER TO NO. 2 VHF FM WIRING DIAGRAM TM 11-1520-248-23.
  - 10. REFER TO VHF AM WIRING DIAGRAM TM 11-1520-248-23.
  - 11. REFER TO HF WIRING DIAGRAM TM 11-1520-248-23.
  - 12. REFER TO ICS WIRING DIAGRAM TM 11-1520-248-23.
  - 13. REFER TO LHF WIRING DIAGRAM TM 11-1520-248-23.
  - 14. REFER TO RADAR ALTIMETER WIRING DIAGRAM TM 11-1520-248-23.
  - 15. REFER TO DOPPLER NAVIGATION WIRING DIAGRAM TM 11-1520-248-23.
  - 16. REFER TO RADAR WARNING WIRING DIAGRAM TM 11-1520-248-23.
  - 17. REFER TO AMRE WIRING DIAGRAM TM 11-1520-248-23.
  - 18. REFER TO ADS SYSTEM WIRING DIAGRAM.
  - 19. REFER TO IFF WIRING DIAGRAM TM 11-1520-248-23.
  - 20. SEE VIEW A FOR IDENTIFICATION OF SWITCH TERMINALS.
  - 21. NUMBERED CIRCLE ON RIGHT SIDE OF SHEET SIGNIFIES "SEE SHEET" AND FIND SAME NUMBER ON LEFT SIDE OF SHEET WITH MATCHING WIRE NUMBER (S).

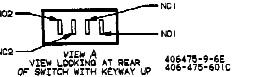

Figure FO-1. DC Power Wiring Diagram (Sheet 6 of 6)

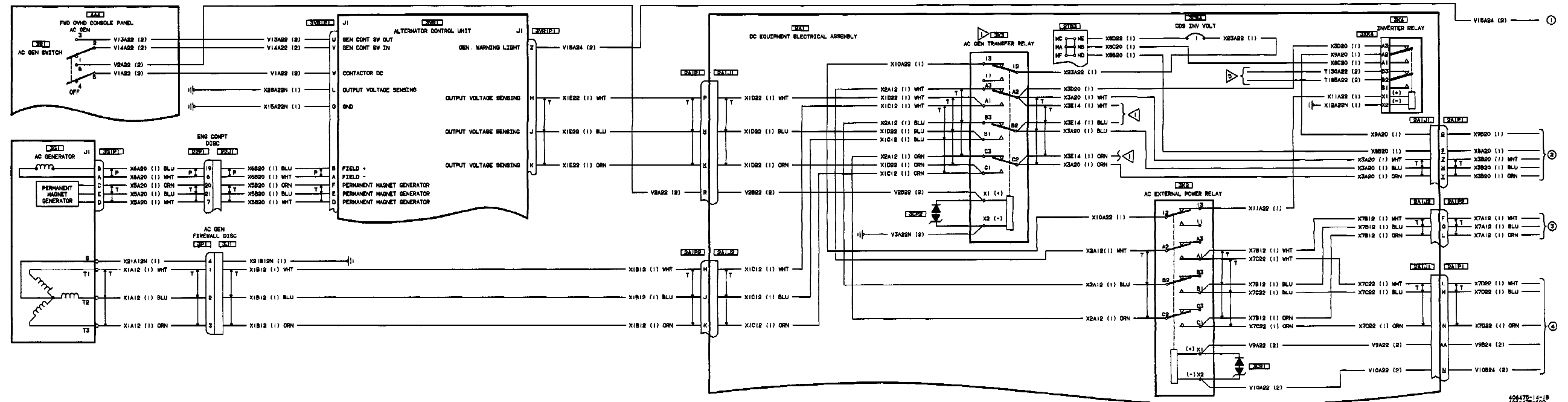

Figure FO-2. AC Power Wiring Diagram (Sheet 1 of 2)

404475-14-1B  
406-476-602



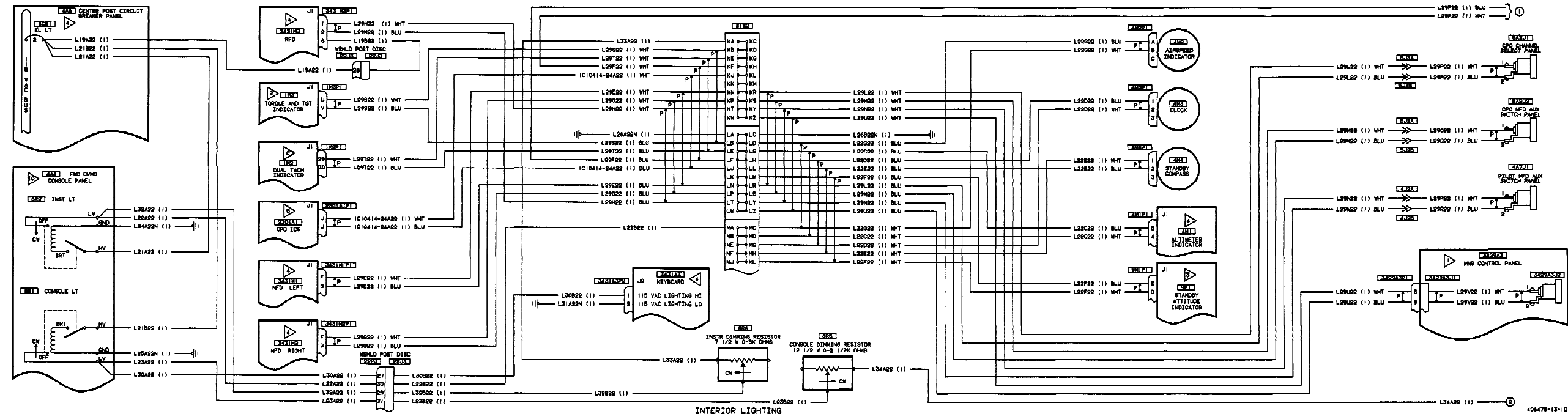

Figure FO-3. Lighting Wiring Diagram (Sheet 1 of 4)

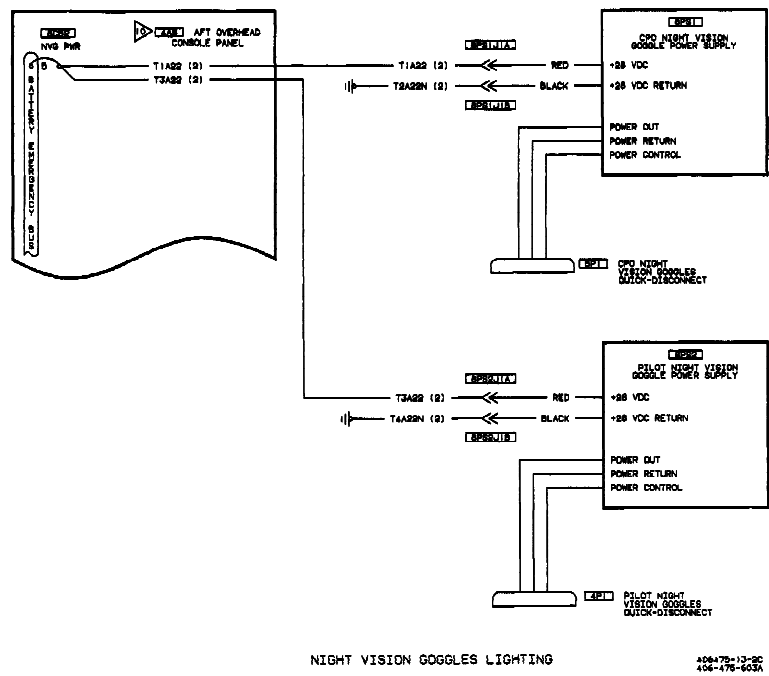
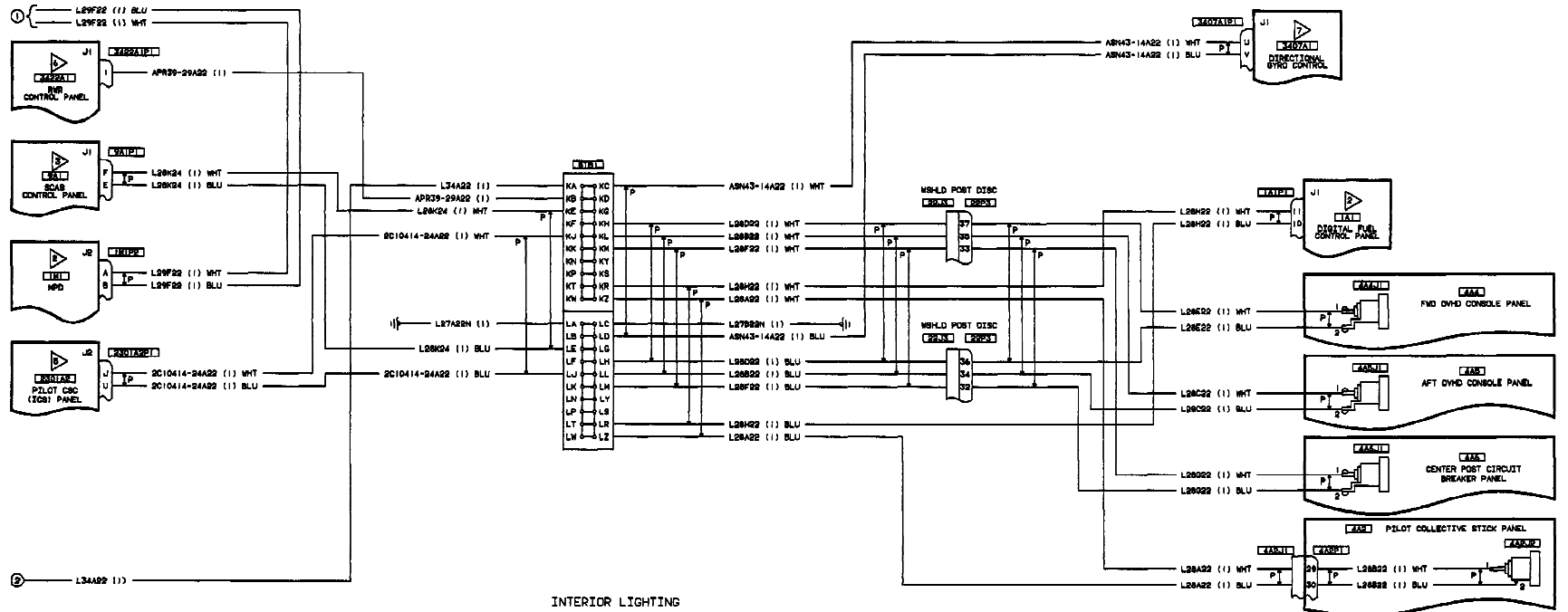

Figure FO-3. Lightening Wiring Diagram (Sheet 2 of 4)

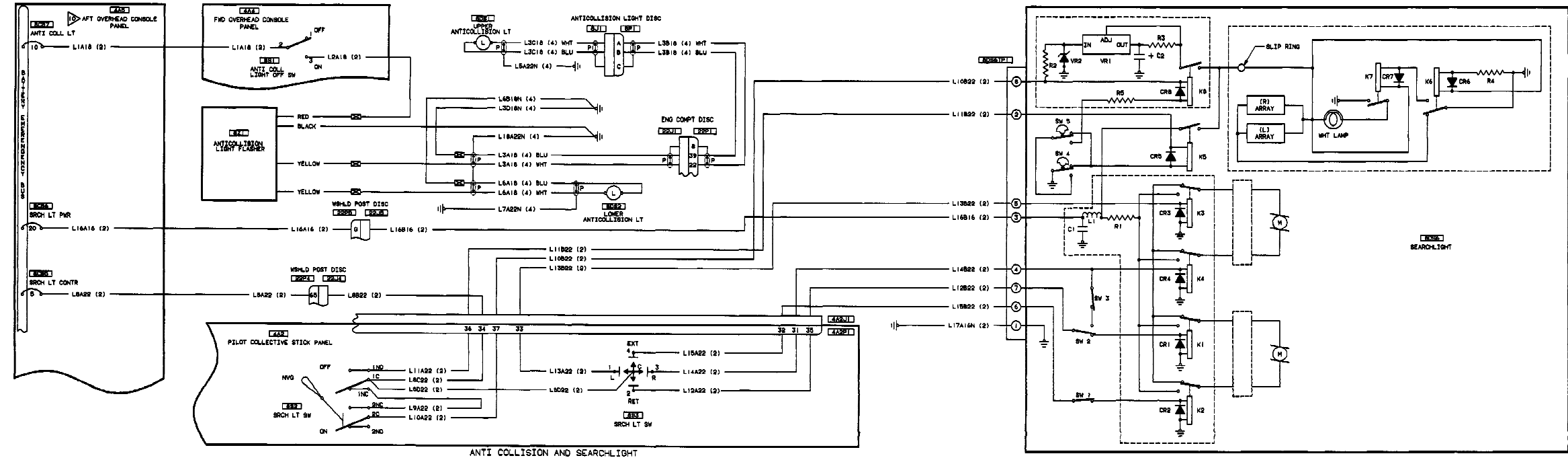
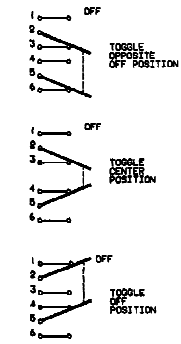
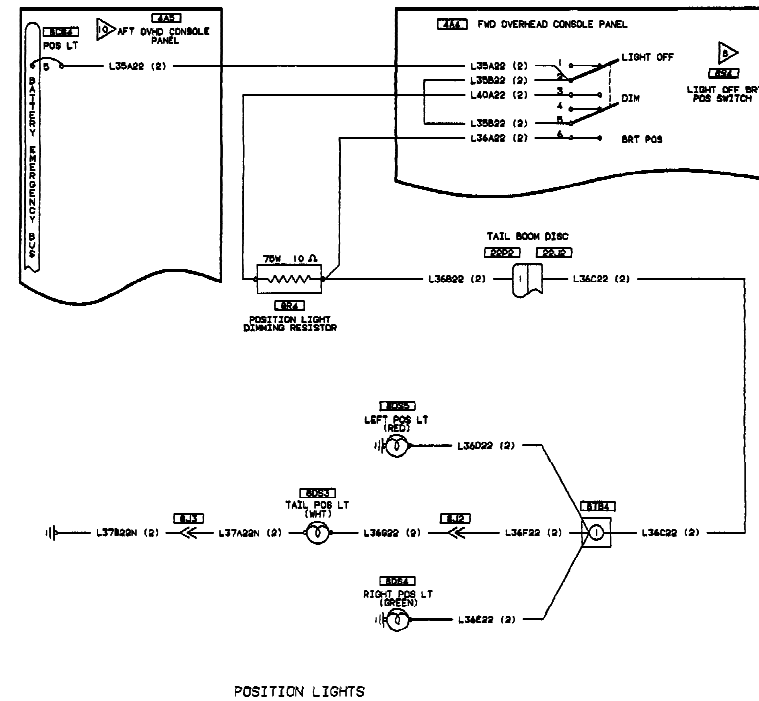
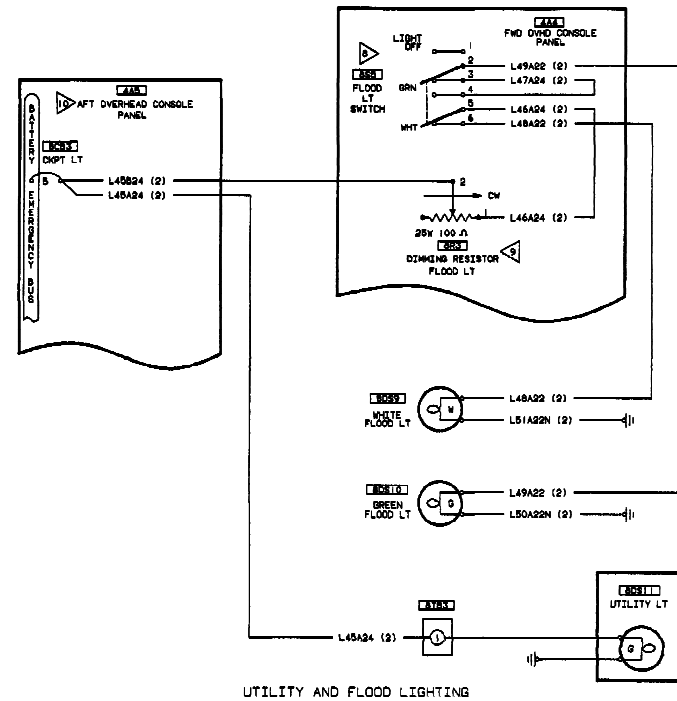
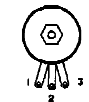

Figure FO-3. Lighting Wiring Diagram (Sheet 3 of 4)



VIEW A  
 SHOWING SWITCH CIRCUIT  
 IN ALL 3 POSITIONS



VIEW B  
 LOOKING AT END  
 OPPOSITE SHAFT

- NOTES**
- 1 REFER TO HHS SYSTEM WIRING DIAGRAM.
  - 2 REFER TO POWER PLANT AND TRANSMISSION SYSTEM WIRING DIAGRAM.
  - 3 REFER TO SCAS, HYDRAULICS AND STANDBY ATTITUDE SYRO SYSTEM WIRING DIAGRAM.
  - 4 REFER TO CDS SYSTEM WIRING DIAGRAM.
  - 5 REFER TO ICS AND ATIS WIRING DIAGRAM, TM 11-1820-248-23.
  - 6 REFER TO RADAR WARNING WIRING DIAGRAM, TM 11-1820-248-23.
  - 7 REFER TO SYNCHRONISTIC WIRING DIAGRAM, TM 11-1820-248-23.
  - 8 SEE VIEW A FOR TOGGLE SWITCH POSITIONS.
  - 9 SEE VIEW B FOR TERMINAL CONNECTIONS.
  - 10 REFER TO DC POWER SYSTEM WIRING DIAGRAM.

Figure FO-3. Lighting Wiring Diagram (Sheet 4 of 4)



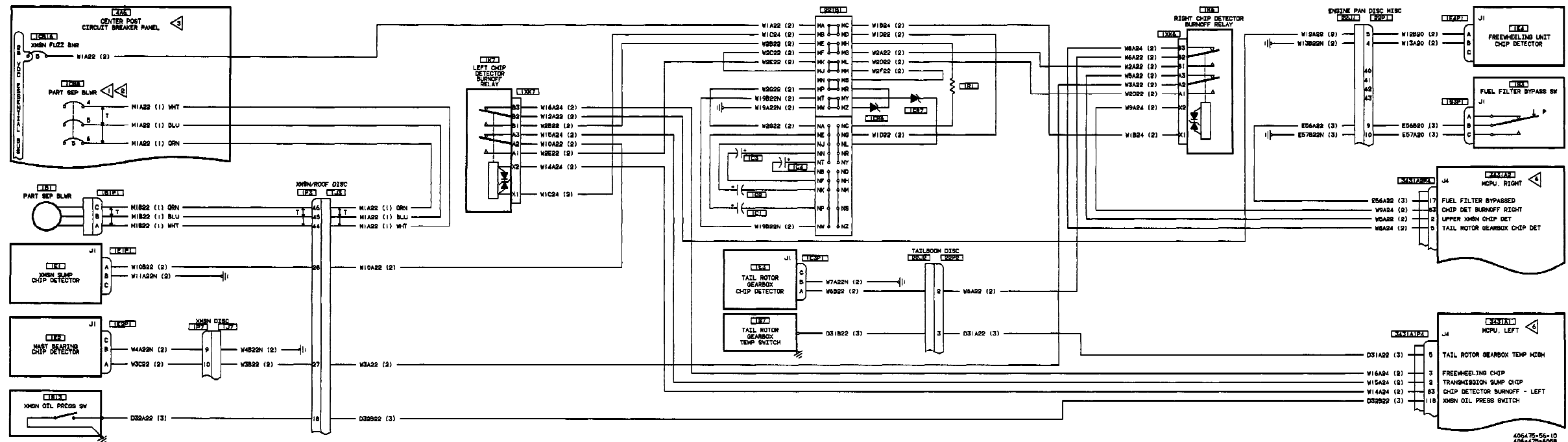

Figure FO-4. Power Plant Transmission Wiring Diagram (Sheet 1 of 8)

406475-56-10  
406-475-6088

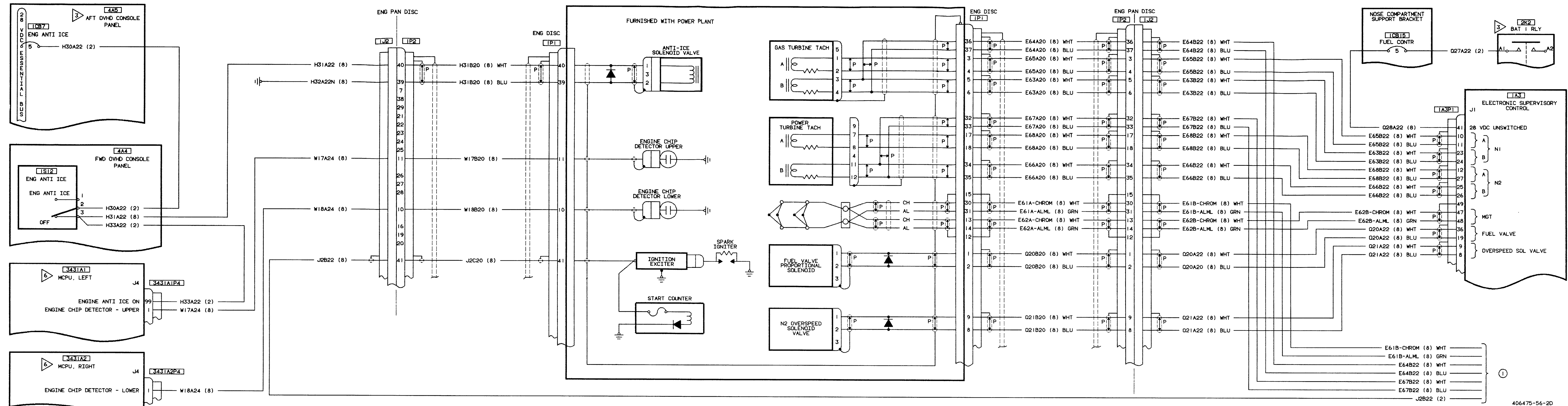

Figure FO-4. Power Plant Transmission Wiring Diagram (Sheet 2 of 8)

406475-56-2D  
406-475-605B



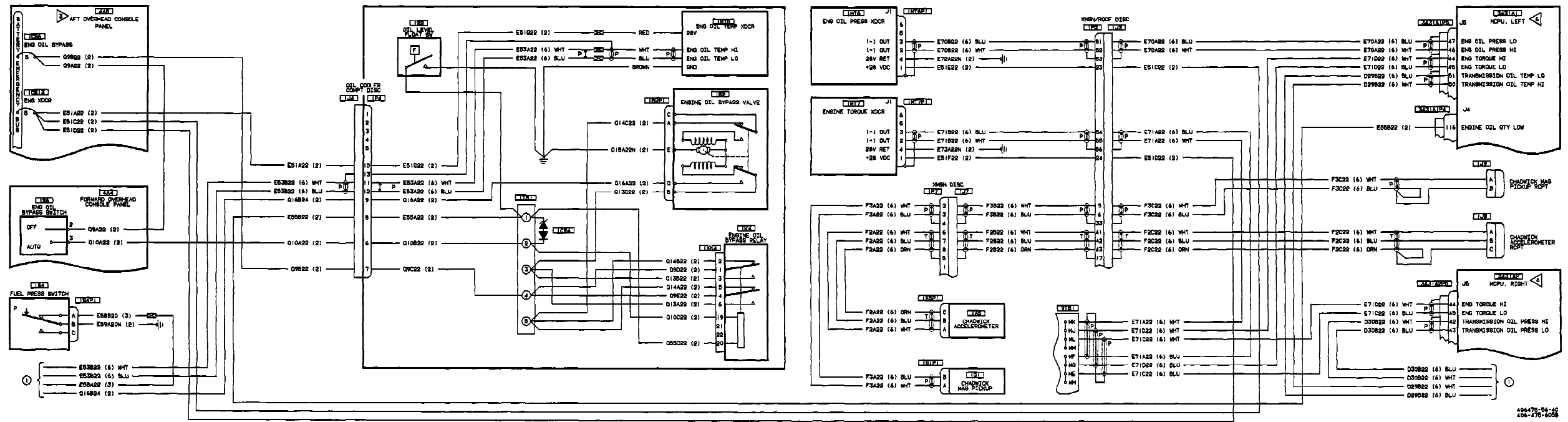
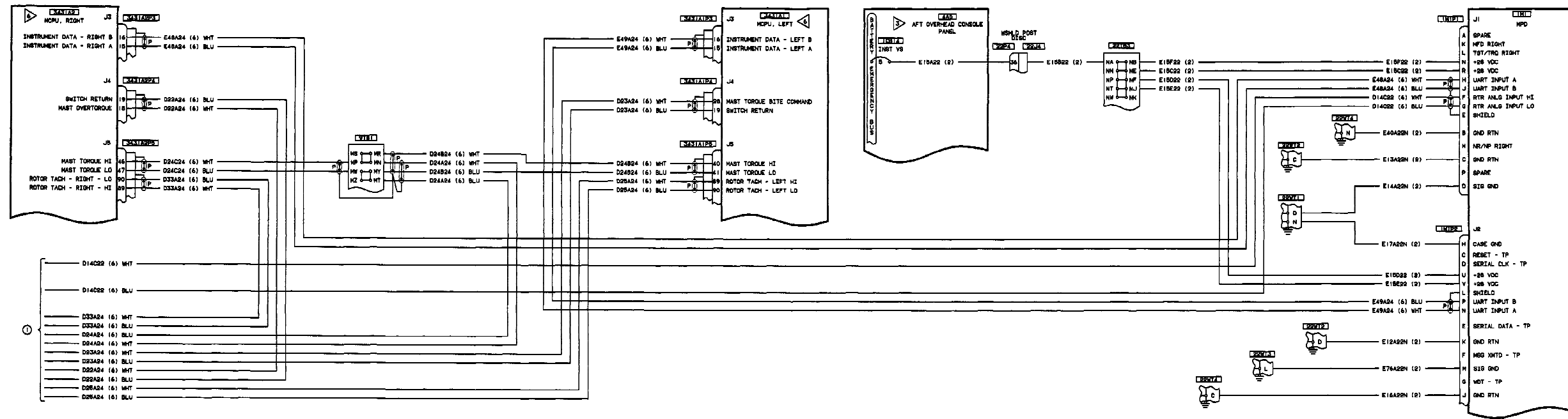

Figure FO-4. Power Plant Transmission Wiring Diagram (Sheet 4 of 8)

496475-54-4C  
496-475-6058





404475-56-9C  
408-475-6008

Figure FO-4. Power Plant Transmission Wiring Diagram (Sheet 6 of 8)



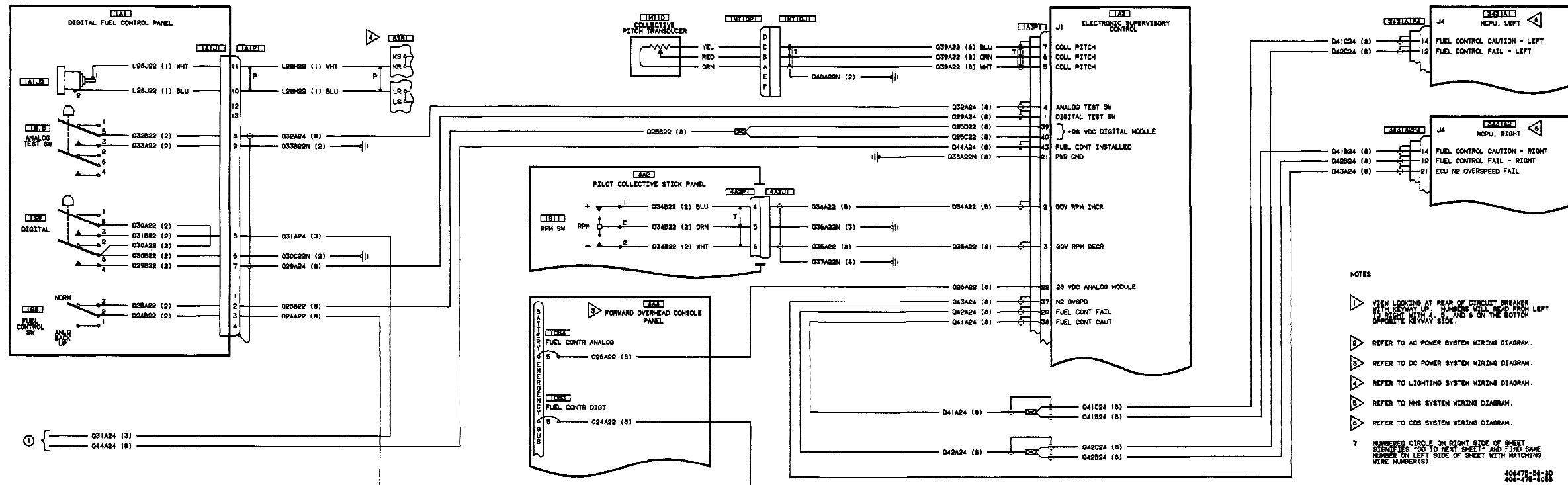
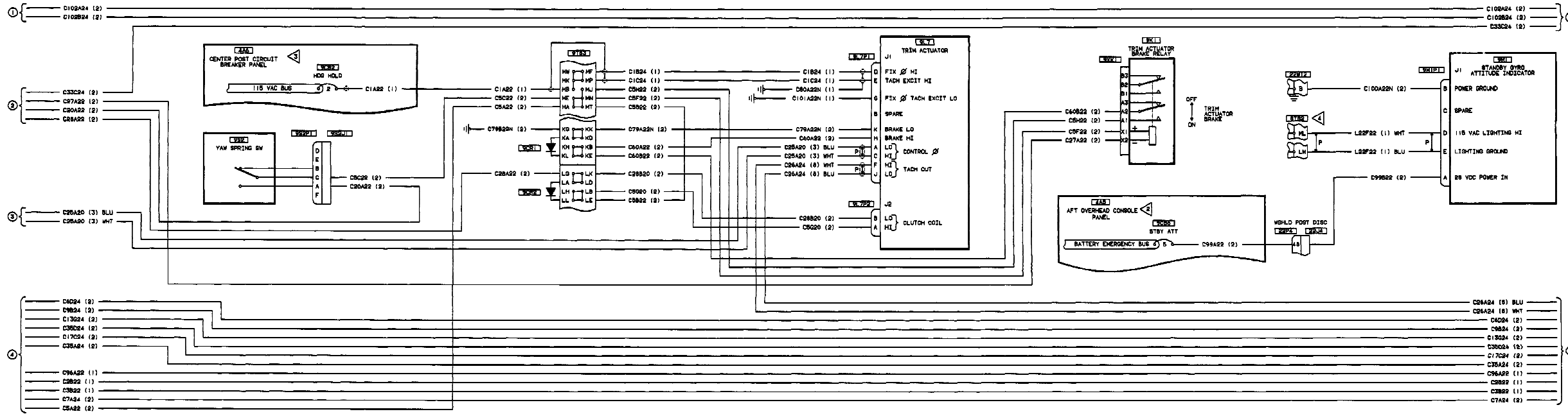

Figure FO-4. Power Plant Transmission Wiring Diagram (Sheet 8 of 8)







40475-11-25  
404-475-601A

Figure FO-5. SCAS Hydraulic, and Standby Attitude Gyro Wiring Diagram (Sheet 2 of 6)

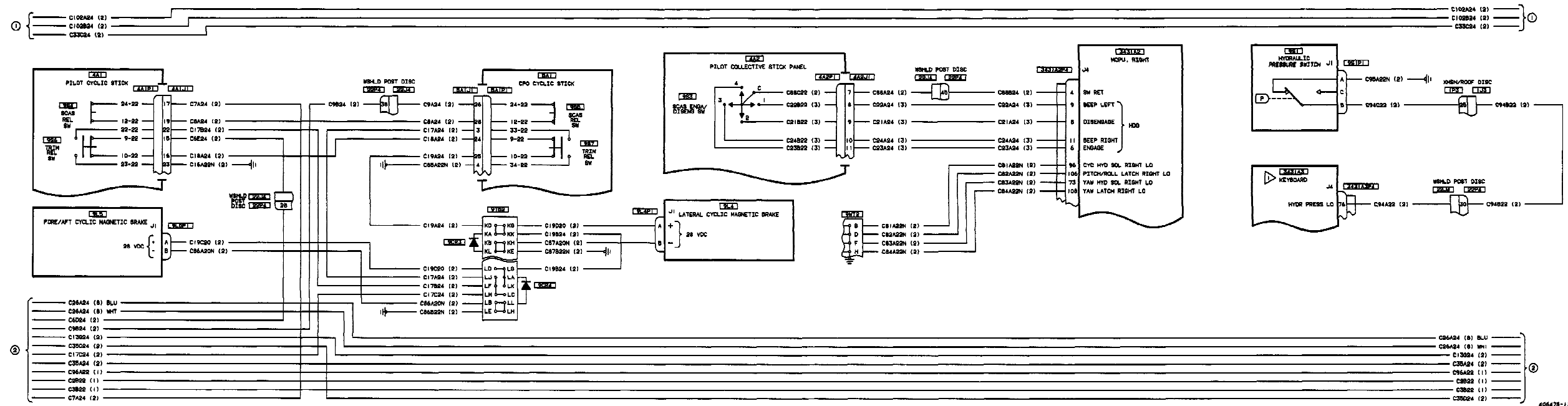

Figure FO-5. SCAS, Hydraulic, and Standby Attitude Gyro Wiring Diagram (Sheet 3 of 6)

406478-11-32  
406-478-806A

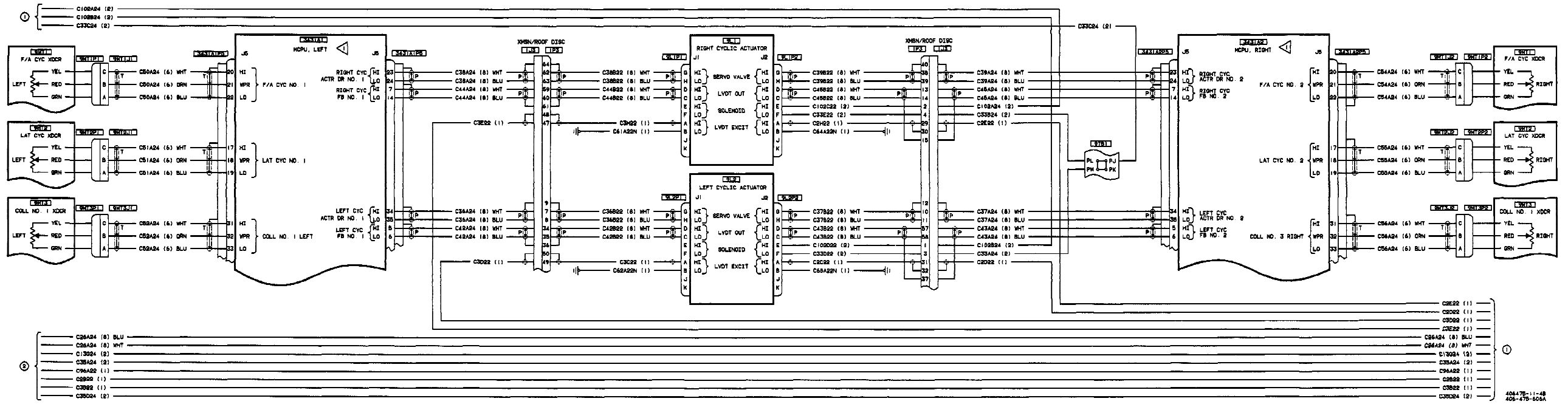

Figure FO-5. SCAS, Hydraulic, and Standby Attitude Gyro Wiring Diagram (Sheet 4 of 6)











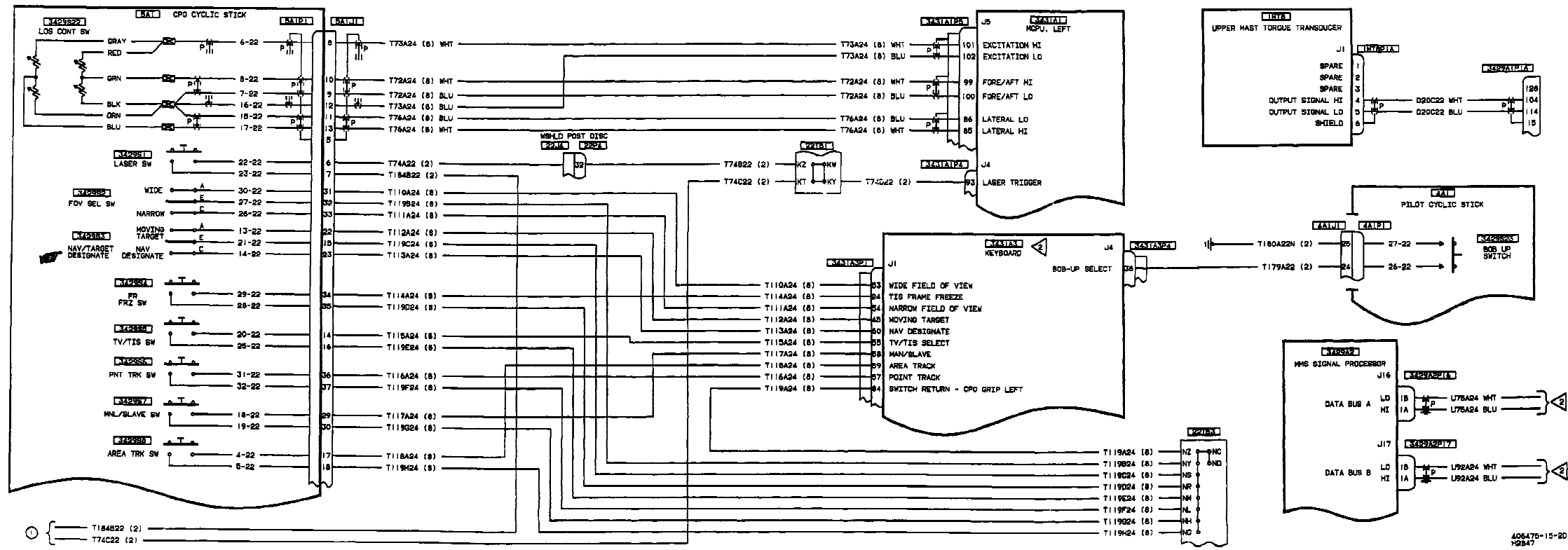
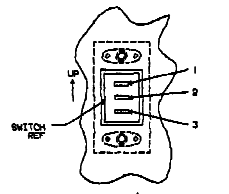
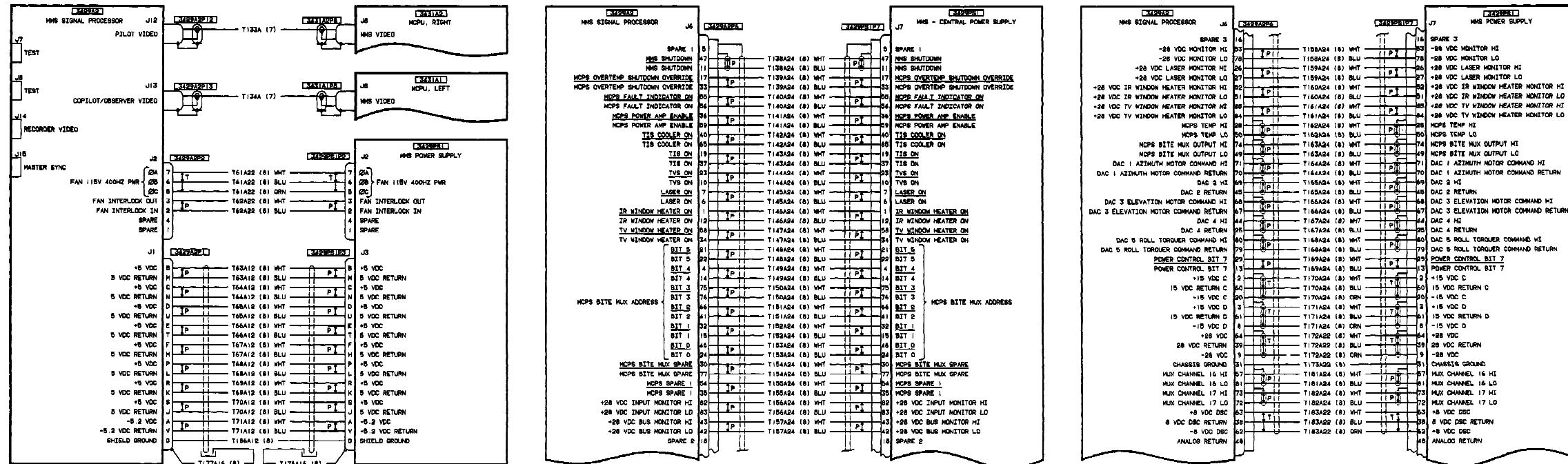

Figure FO-7. MMS Wiring Diagram (Sheet 2 of 4)

406475-15-20  
12847





VIEW A  
VIEW LOOKING AT REAR OF SWITCH AS INSTALLED IN PANEL TO SHOW SWITCH IDENTIFICATION.

- NOTES
- 1 REFER TO POWER BLUNT AND TRANSMISSION SYSTEM WIRING DIAGRAM.
  - 2 REFER TO COS SYSTEM WIRING DIAGRAM.
  - 3 REFER TO DC POWER SYSTEM WIRING DIAGRAM.
  - 4 REFER TO AC POWER SYSTEM WIRING DIAGRAM.
  - 5 REFER TO LIGHTING SYSTEM WIRING DIAGRAM.
  - 6 FURNISHED CONNECTOR CONTACT IDENTIFICATION FOR TERMINATING A 5-CONDUCTOR SHIELDED BICHERED CABLE SHALL BE AS FOLLOWS:  
2 = PIN CONTACT  
3 = SOCKET CONTACT
  - 7 SEE VIEW A FOR SWITCH TERMINAL IDENTIFICATION
  - 8 SEE VIEW A FOR SWITCH TERMINAL IDENTIFICATION
  - 9 NUMBERED CIRCLE ON RIGHT SIDE OF SHEET IDENTIFIES WIRE TO NEXT SHEET\*  
\*WIRE NUMBER ON LEFT SIDE OF SHEET WITH MATCHING WIRE NUMBER(S).

406476-15-4D  
406-476-606A

Figure FO-7. MMS Wiring Diagram (Sheet 4 of 4)

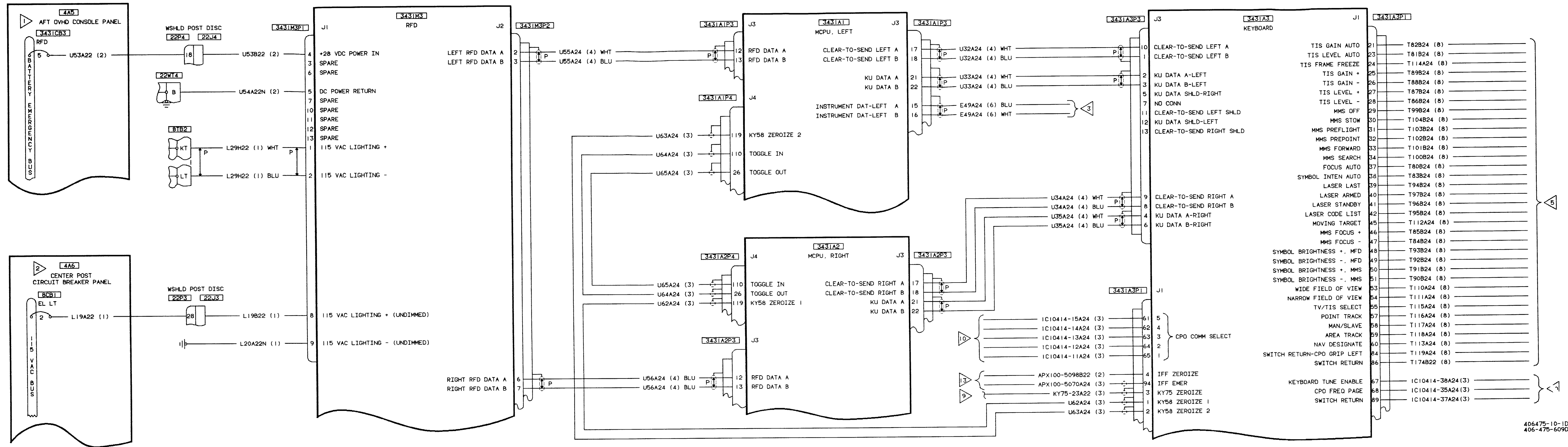

Figure FO-8. CDS Wiring Diagram (Sheet 1 of 9)

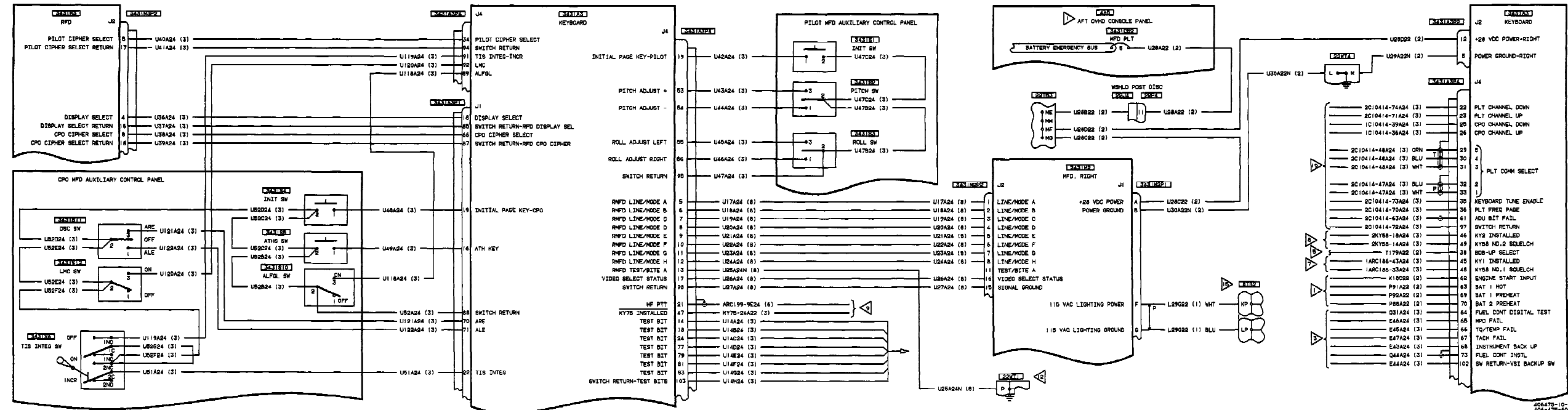
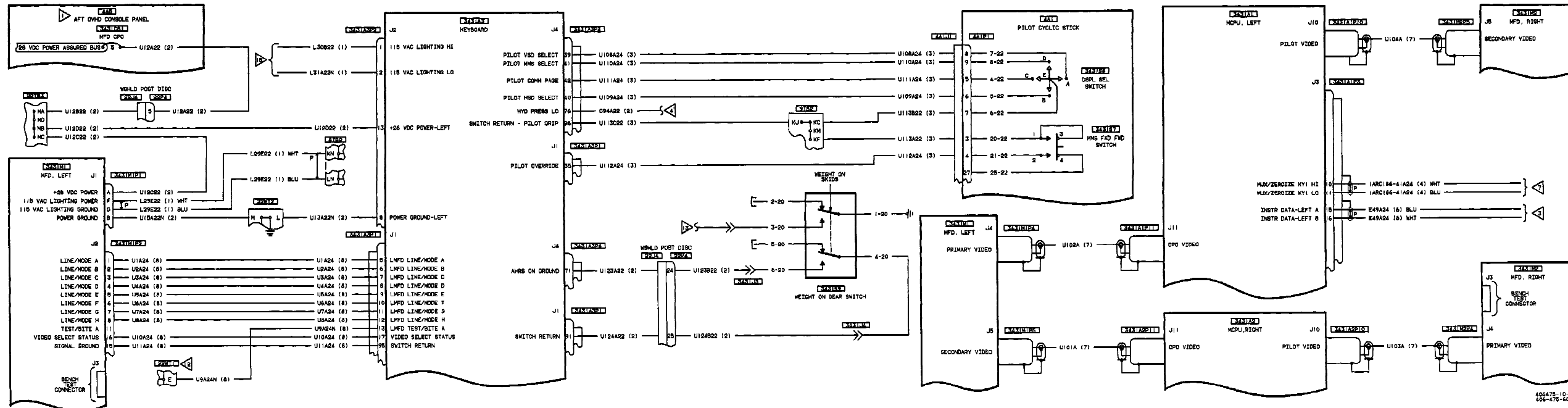

Figure FO-8. CDS Wiring Diagram (Sheet 2 of 9)

406475-10-2E  
406475-4090



406475-10-3E  
406-475-6090

Figure FO-8. CDS Wiring Diagram (Sheet 3 of 9)

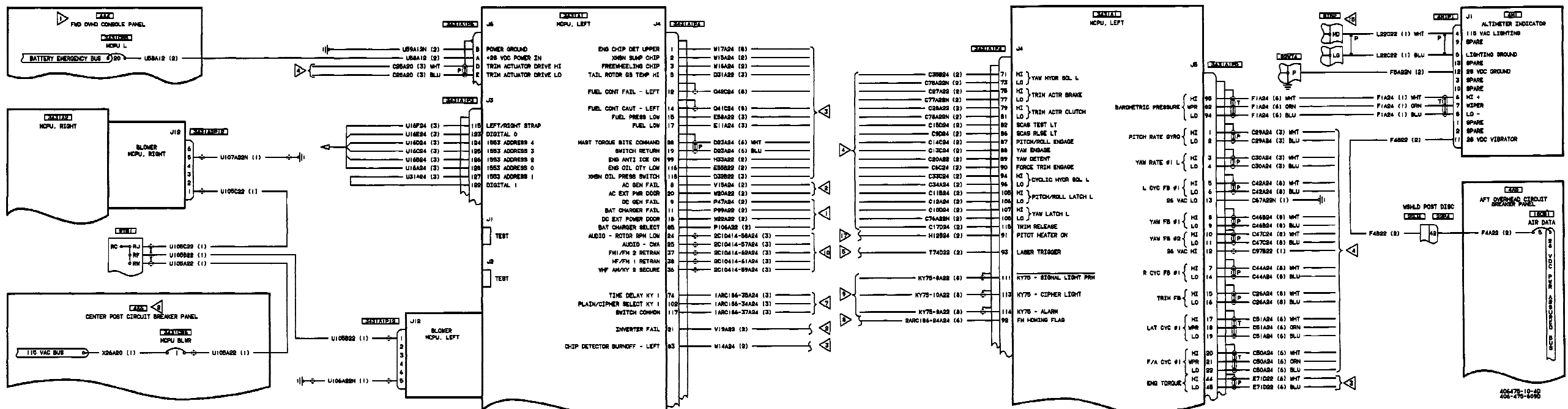
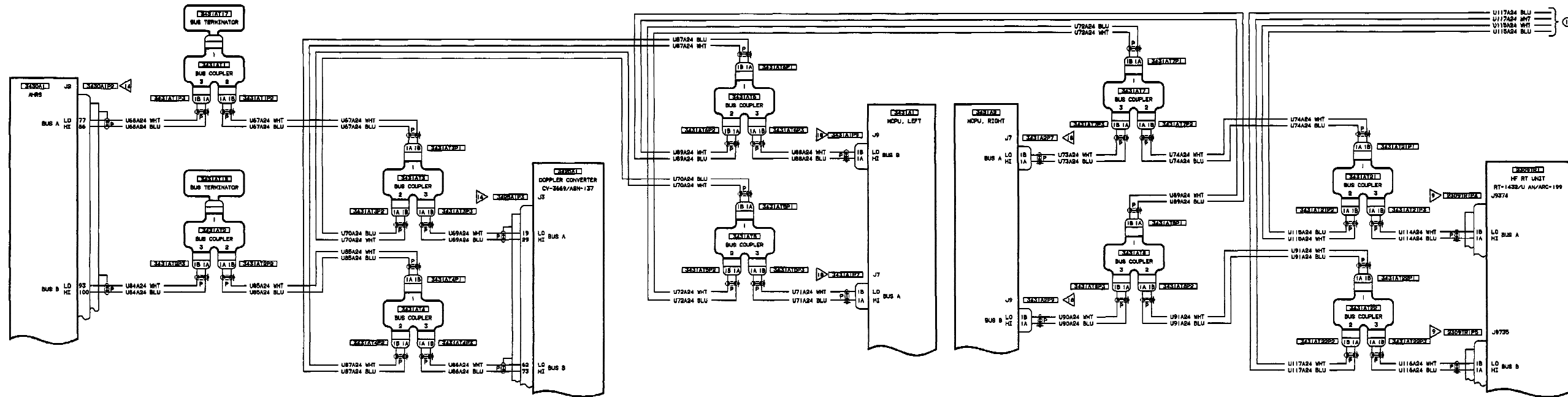

Figure FO-8 CDS Wiring Diagram (Sheet 4 of 9)

406475-10-02  
406-475-6090







404475-10-82  
406-475-6096

Figure FO-8. CDS Wiring Diagram (Sheet 6 of 9)

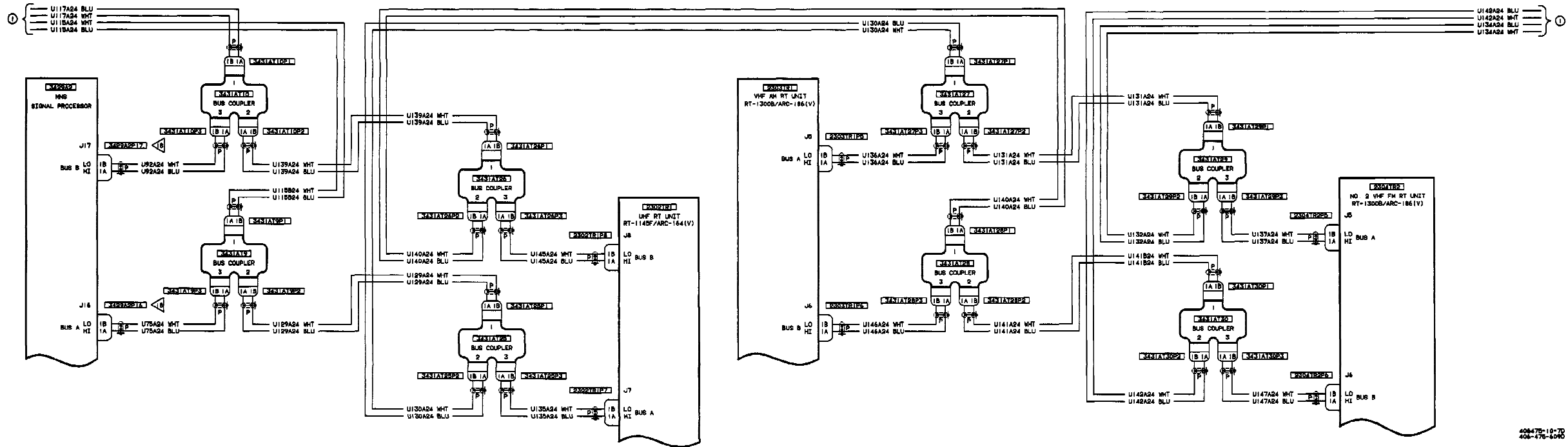

Figure FO-8. CDS Wiring Diagram (Sheet 7 of 9)

408475-10-7D  
408-475-6095

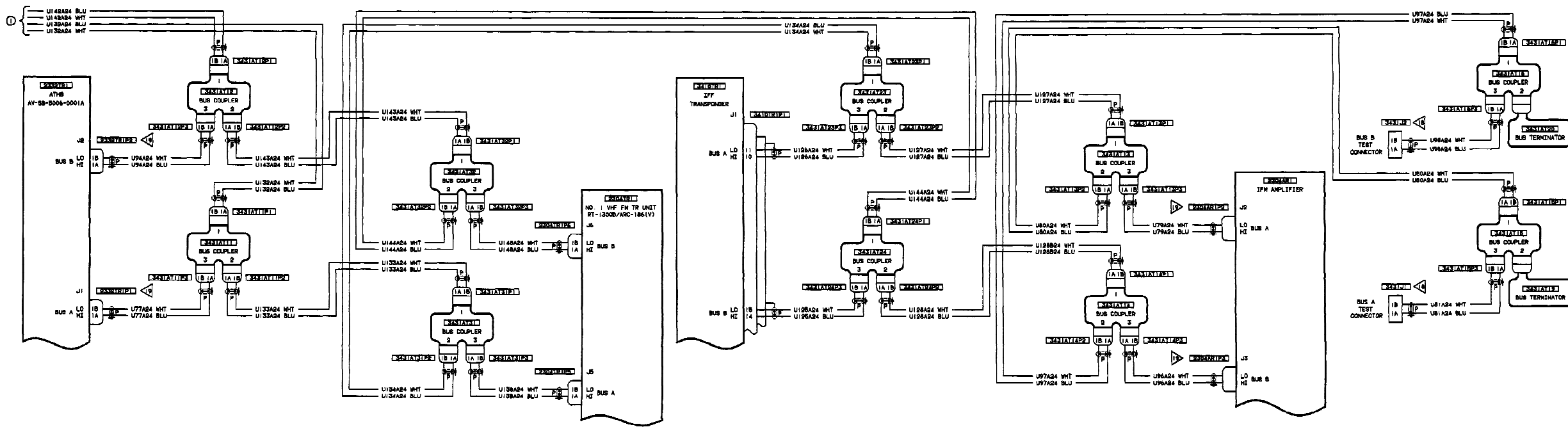
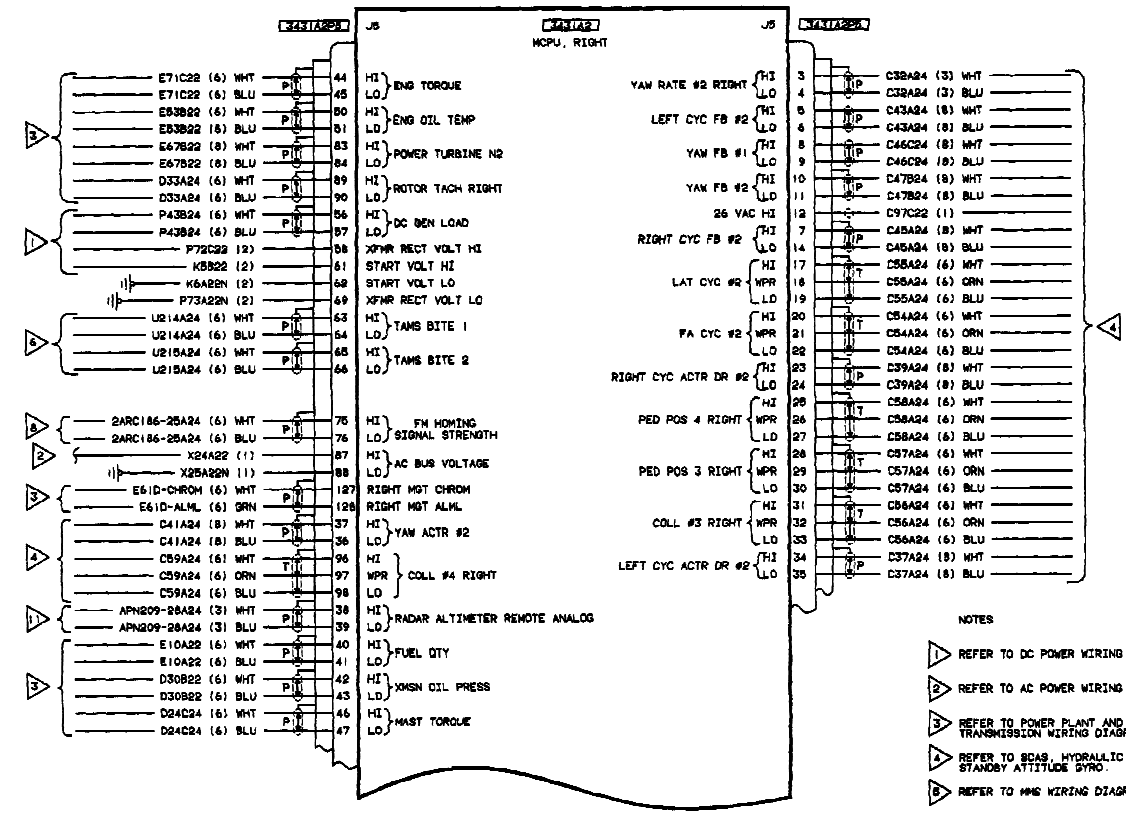
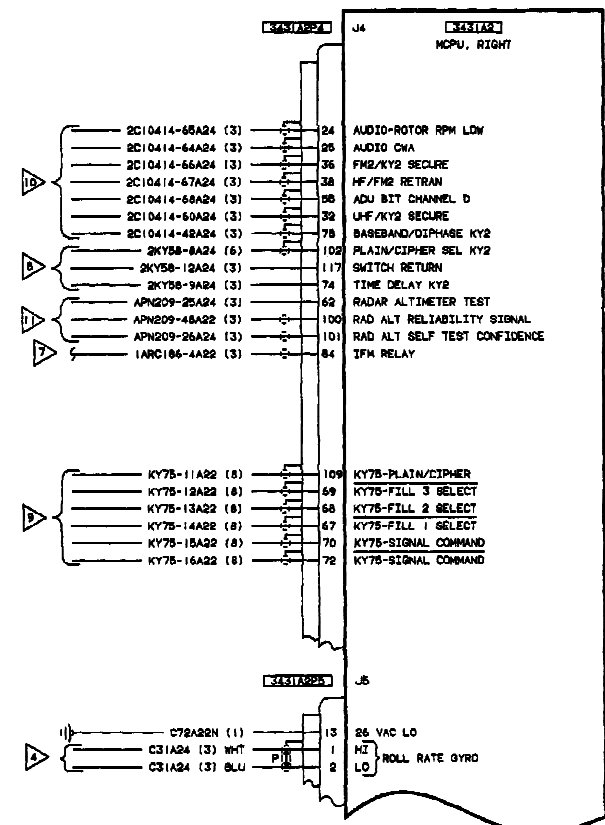

Figure FO-8. CDS Wiring Diagram (Sheet 8 of 9)



- 1 REFER TO TRANSMISSION ALIGNMENT MEASUREMENT SYSTEM WIRING DIAGRAM.
- 2 REFER TO NO. 1 VHF FM WIRING DIAGRAM TM 11-1520-248-23.
- 3 REFER TO NO. 2 VHF FM WIRING DIAGRAM TM 11-1520-248-23.
- 4 REFER TO HF WIRING DIAGRAM TM 11-1520-248-23.
- 5 REFER TO ICS WIRING DIAGRAM TM 11-1520-248-23.
- 6 REFER TO RADAR ALTIMETER WIRING DIAGRAM TM 11-1520-248-23.
- 7 REFER TO ADS SYSTEM WIRING DIAGRAM.
- 8 REFER TO IFF WIRING DIAGRAM TM 11-1520-248-23.
- 9 REFER TO DOPPLER NAVIGATION WIRING DIAGRAM TM 11-1520-248-23.
- 10 REFER TO LIGHTING SYSTEM WIRING DIAGRAM.
- 11 REFER TO AMRS WIRING DIAGRAM TM 11-1520-248-23.
- 12 REFER TO ENVIRONMENTAL ELECTRICAL SYSTEM WIRING DIAGRAM.
- 13 CONNECTOR CONTACT SUFFIX LETTERS ARE DEFINED AS FOLLOWS:  
A-DENOTES CONNECTOR CONTACT INNER CONDUCTOR  
B-DENOTES CONNECTOR CONTACT OUTER CONDUCTOR  
ONE CONTACT IS REQUIRED FOR TWO WIRES PER CONTACT CAVITY
- 14 WHEN INSTALLING A TWISTED SHIELDED PAIR IN A TRIAX TYPE CONNECTOR, TERMINATIONS ARE DEFINED AS FOLLOWS:  
BLU = CENTER CONDUCTOR (HI)  
WHT = INTERMEDIATE CONDUCTOR (LO)
- 20 NUMBERED CIRCLE ON RIGHT SIDE SIGNIFIES #20 TO NEXT SHEET AND FIND SAME NUMBER ON LEFT SIDE OF SHEET WITH MATCHING NUMBER(S).

- NOTES
- 1 REFER TO DC POWER WIRING DIAGRAM.
  - 2 REFER TO AC POWER WIRING DIAGRAM.
  - 3 REFER TO POWER PLANT AND TRANSMISSION WIRING DIAGRAM.
  - 4 REFER TO SDAS, HYDRAULIC, AND STANDBY ATTITUDE GYRO.
  - 5 REFER TO HHS WIRING DIAGRAM.

406475-(0-90)  
406-478-6090

Figure FO-8. CDS Wiring Diagram (Sheet 9 of 9)

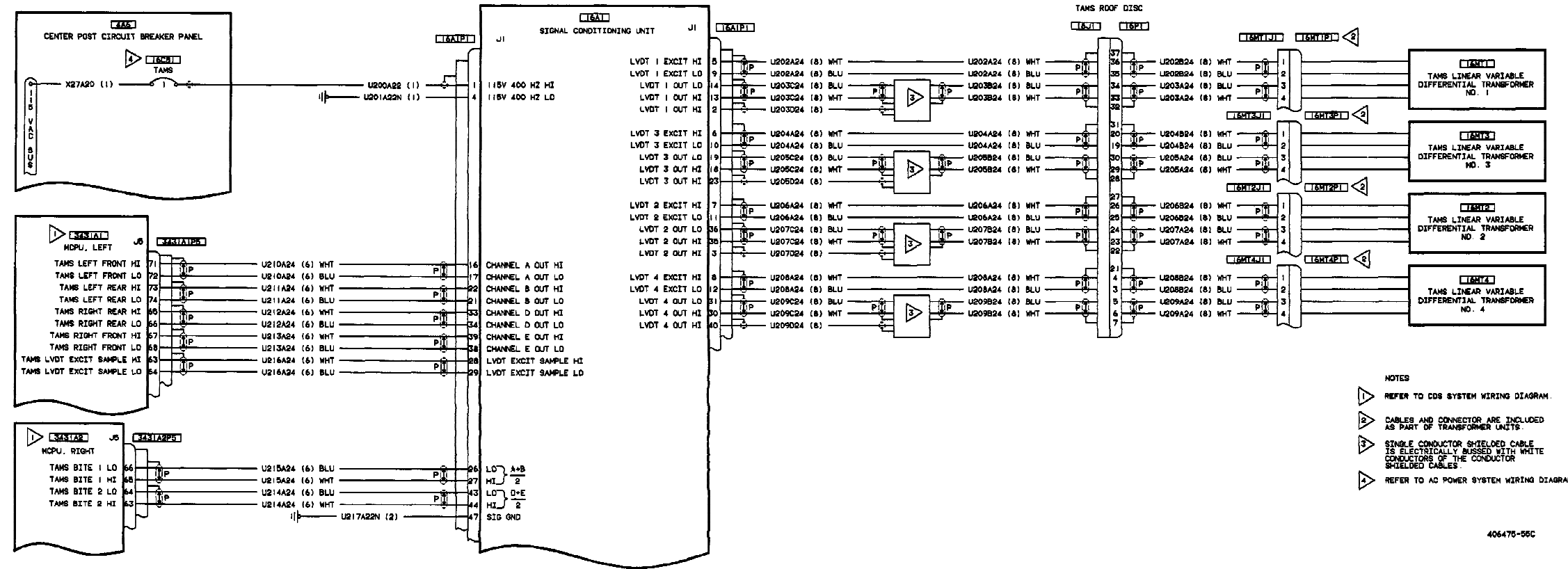

406470-55C

Figure FO-9. TAMS Wiring Diagram

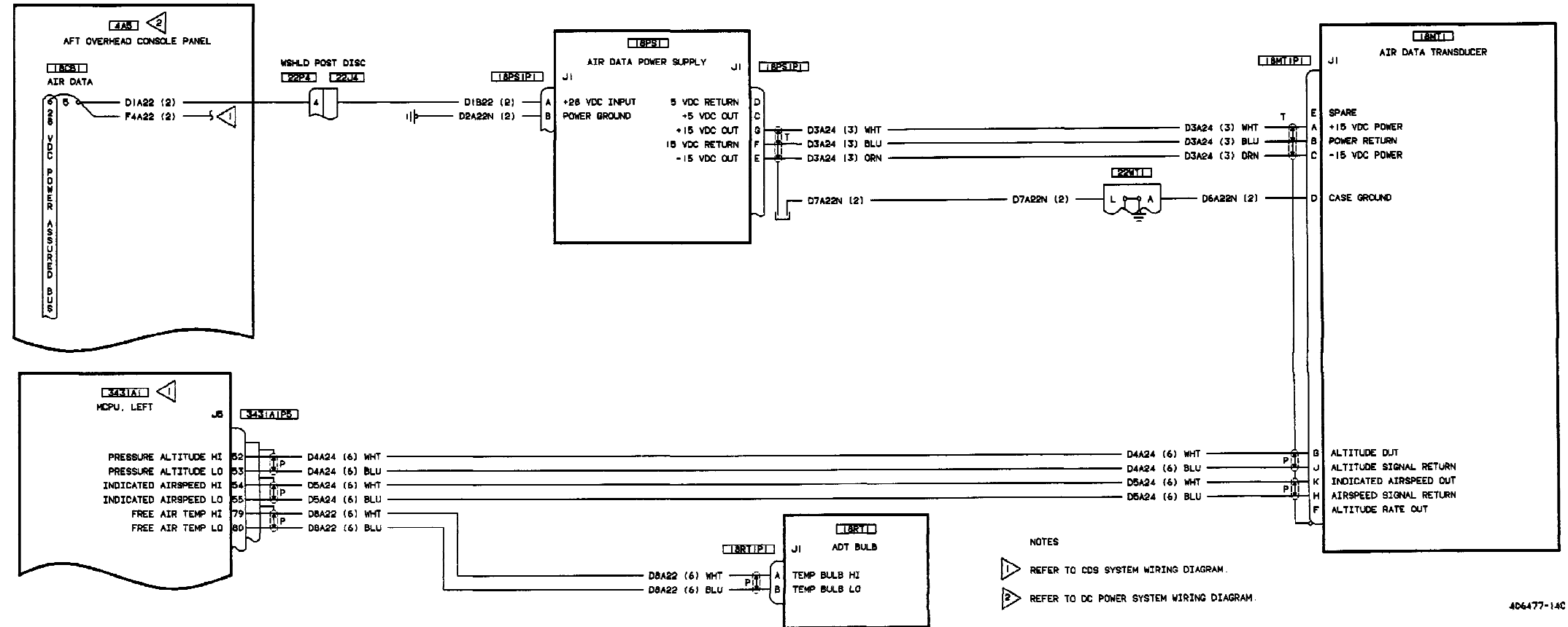

406477-14C

Figure FO-10. ADS Wiring Diagram









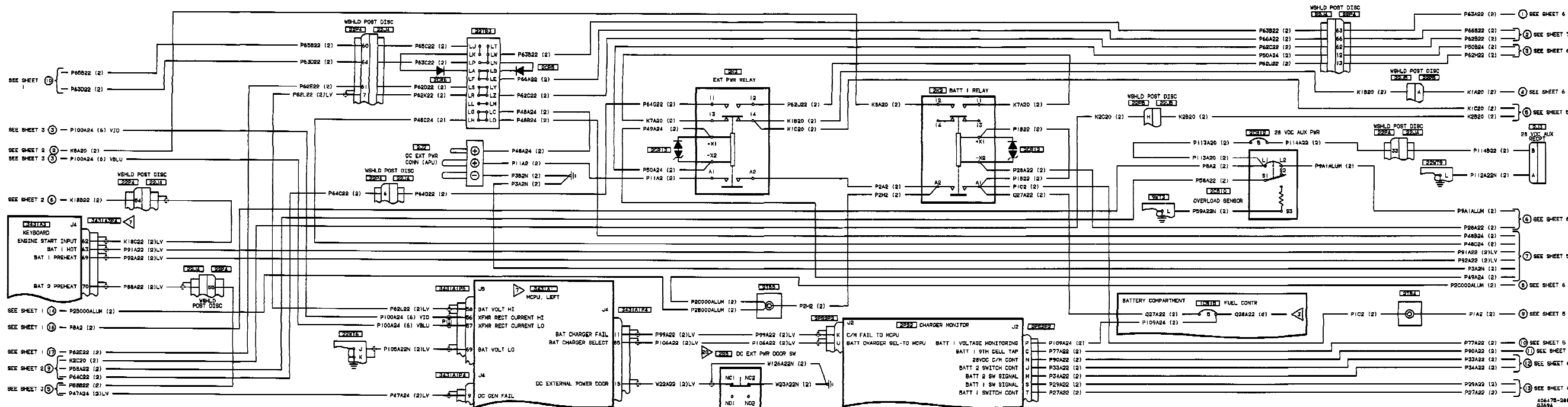

FO-11. DC Power System Wiring Diagram (Sheet 4 of 8)

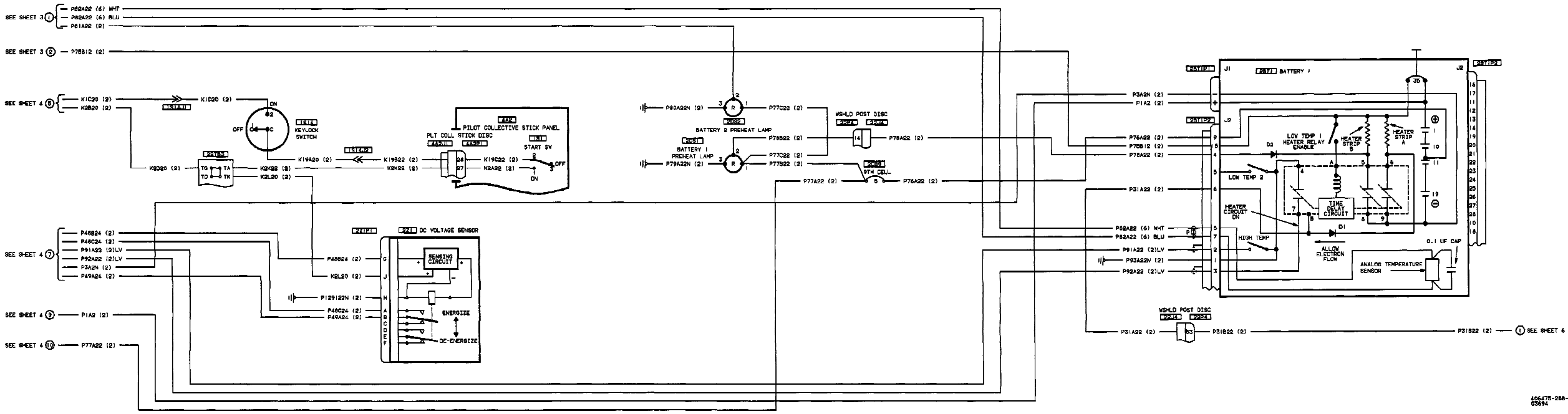

FO-11. DC Power System Wiring Diagram (Sheet 5 of 8)

406475-288-5  
63694

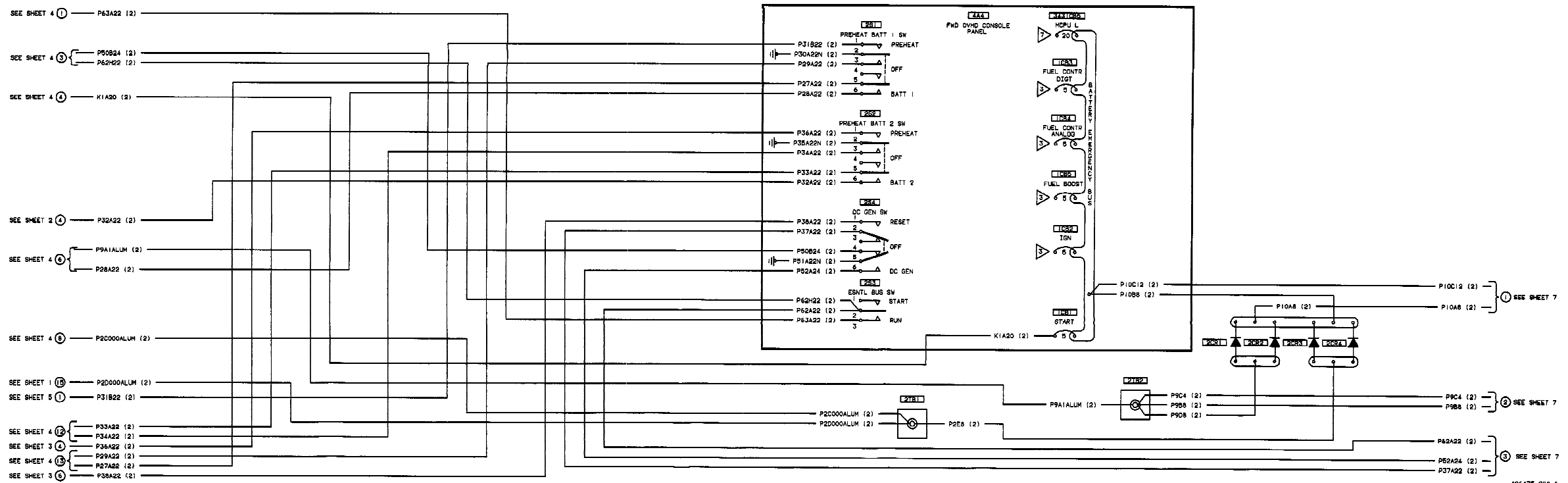

FO-11. DC Power System Wiring Diagram (Sheet 6 of 8)

406475-285-5  
03694

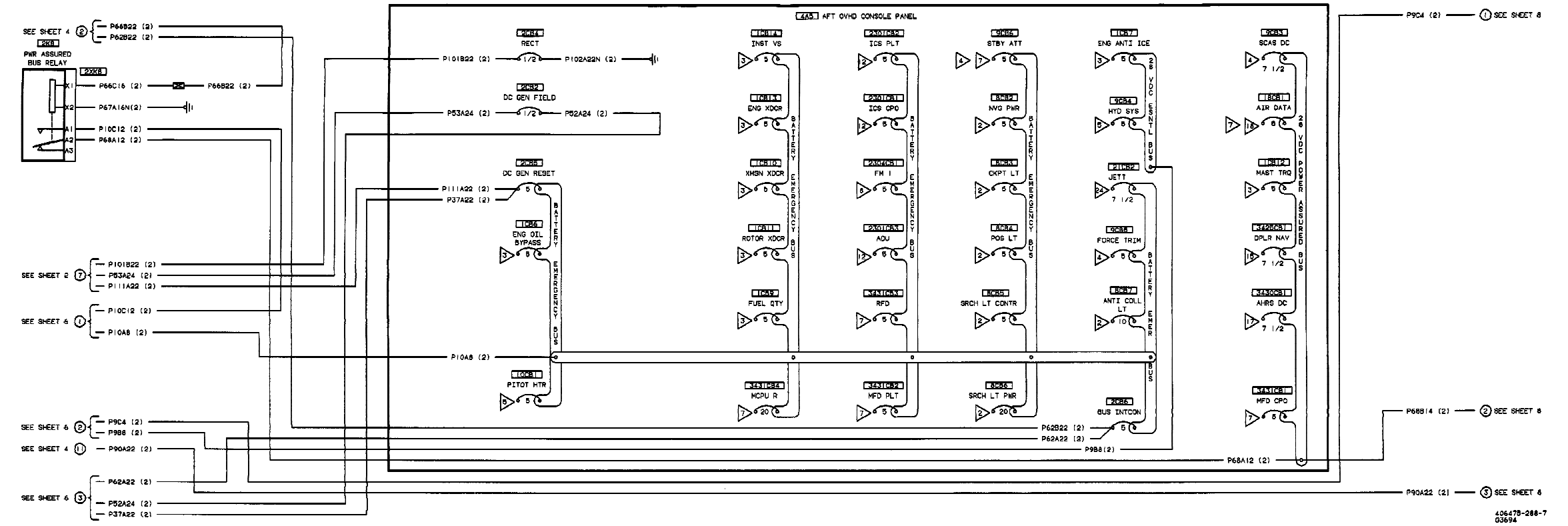

FO-11. DC Power System Wiring Diagram (Sheet 7 of 8)

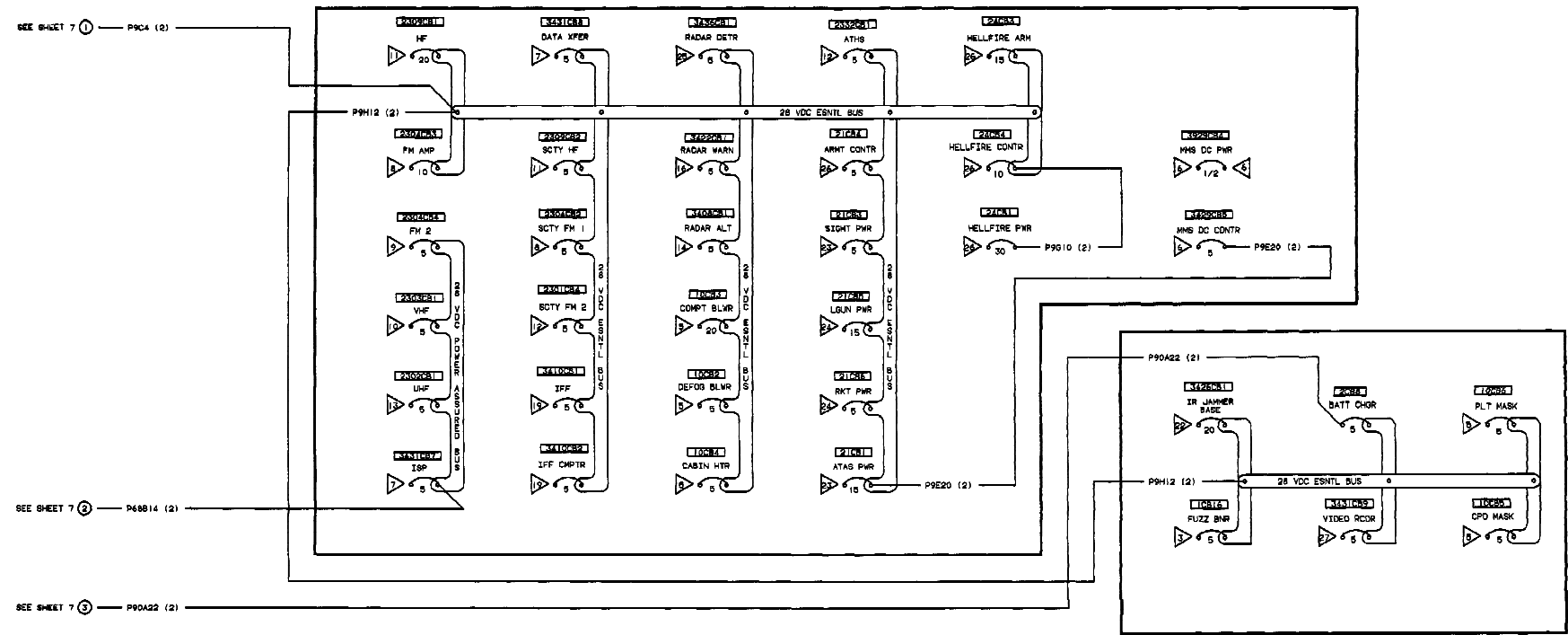

- NOTES
- REFER TO AC POWER SYSTEM WIRING DIAGRAM.
  - REFER TO LIGHTING SYSTEM WIRING DIAGRAM.
  - REFER TO POWER PLANT AND TRANSMISSION SYSTEM WIRING DIAGRAM.
  - REFER TO SCAS, HYDRAULIC, AND STANDBY ATTITUDE CYRO SYSTEM WIRING DIAGRAM.
  - REFER TO ENVIRONMENTAL SYSTEM WIRING DIAGRAM.
  - REFER TO HMS SYSTEM WIRING DIAGRAM.
  - REFER TO CDS SYSTEM WIRING DIAGRAM.
  - REFER TO NO. 1 VHF FM WIRING DIAGRAM TM 11-1520-248-23.
  - REFER TO NO. 2 VHF FM WIRING DIAGRAM TM 11-1520-248-23.
  - REFER TO VHF AM WIRING DIAGRAM TM 11-1520-248-23.
  - REFER TO HF WIRING DIAGRAM TM 11-1520-248-23.
  - REFER TO ICS WIRING DIAGRAM TM 11-1520-248-23.
  - REFER TO UHF WIRING DIAGRAM TM 11-1520-248-23.
  - REFER TO RADAR ALTIMETER WIRING DIAGRAM TM 11-1520-248-23.
  - REFER TO DOPPLER NAVIGATION WIRING DIAGRAM TM 11-1520-248-23.
  - REFER TO RADAR WARNING WIRING DIAGRAM TM 11-1520-248-23.
  - REFER TO AHS WIRING DIAGRAM TM 11-1520-248-23.
  - REFER TO ADS SYSTEM WIRING DIAGRAM.
  - REFER TO IFF WIRING DIAGRAM TM 11-1520-248-23.
  - SEE VIEW A FOR IDENTIFICATION OF SWITCH TERMINALS.
- 21 NUMBERED CIRCLE ON RIGHT SIDE OF SHEET IDENTIFIES "SEE SHEET" AND FIND SAME NUMBER ON LEFT SIDE OF SHEET WITH MATCHING WIRE NUMBER (S).
  - REFER TO IR JAMMER AN/ALQ-144 WIRING DIAGRAM TM 11-1520-248-23.
  - REFER TO ATAS SYSTEM WIRING DIAGRAM.
  - REFER TO GUN AND ROCKETS WIRING DIAGRAM.
  - REFER TO AN/APR-44 RADAR DETECTOR WIRING DIAGRAM.
  - REFER TO HELLFIRE WIRING DIAGRAM.
  - REFER TO VIDEO TAPE RECORDER WIRING DIAGRAM.



406470-288-8  
63694

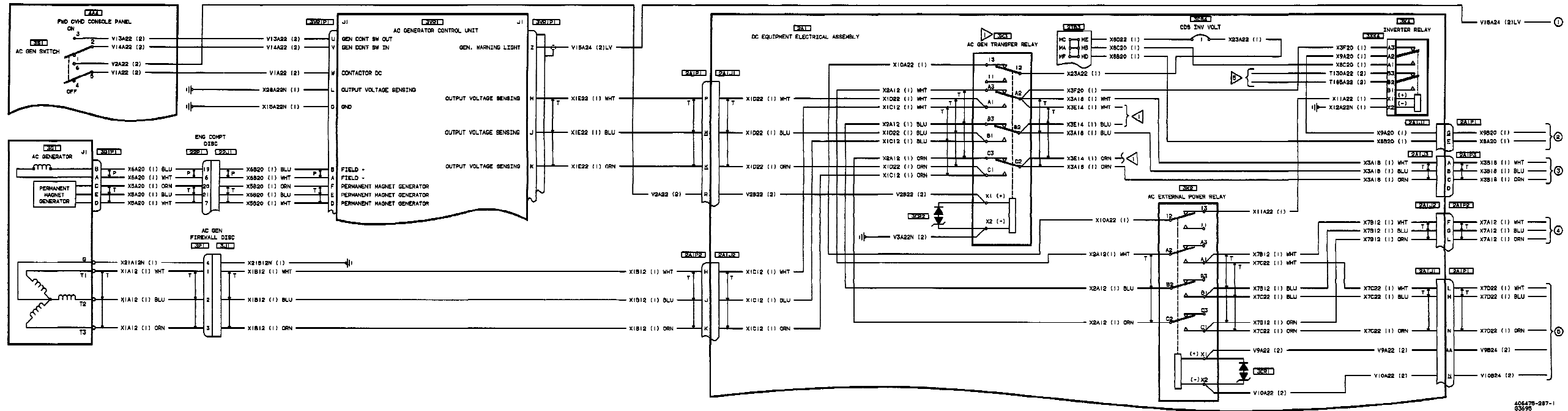

FO-12. AC Power System Wiring Diagram (Sheet 1 of 2)

406475-287-1  
03695







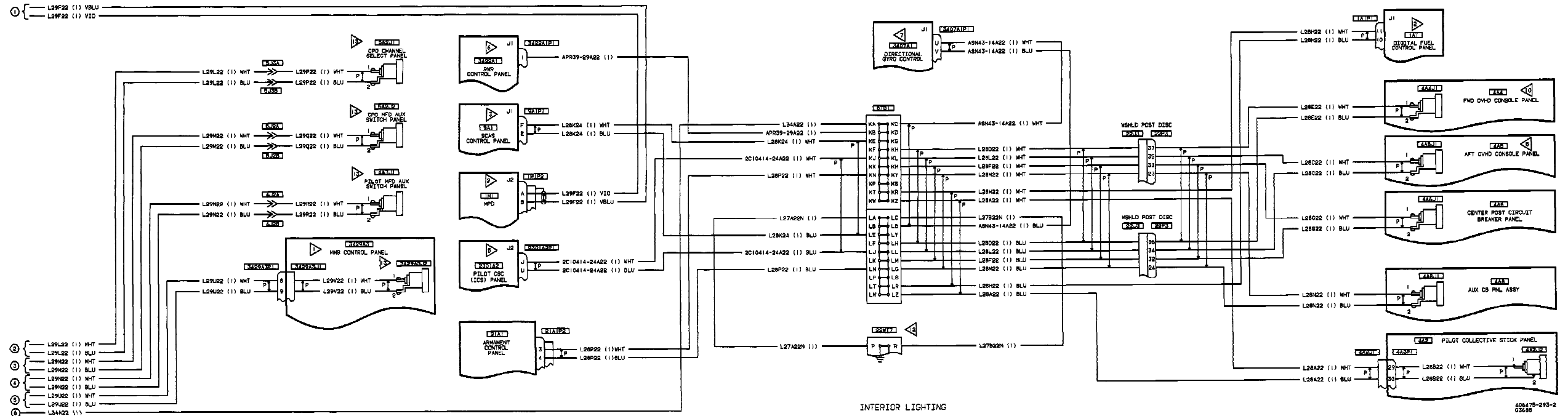

FO-13. Lighting Systems Wiring Diagram (Sheet 2 of 5)

408475-293-2  
03686

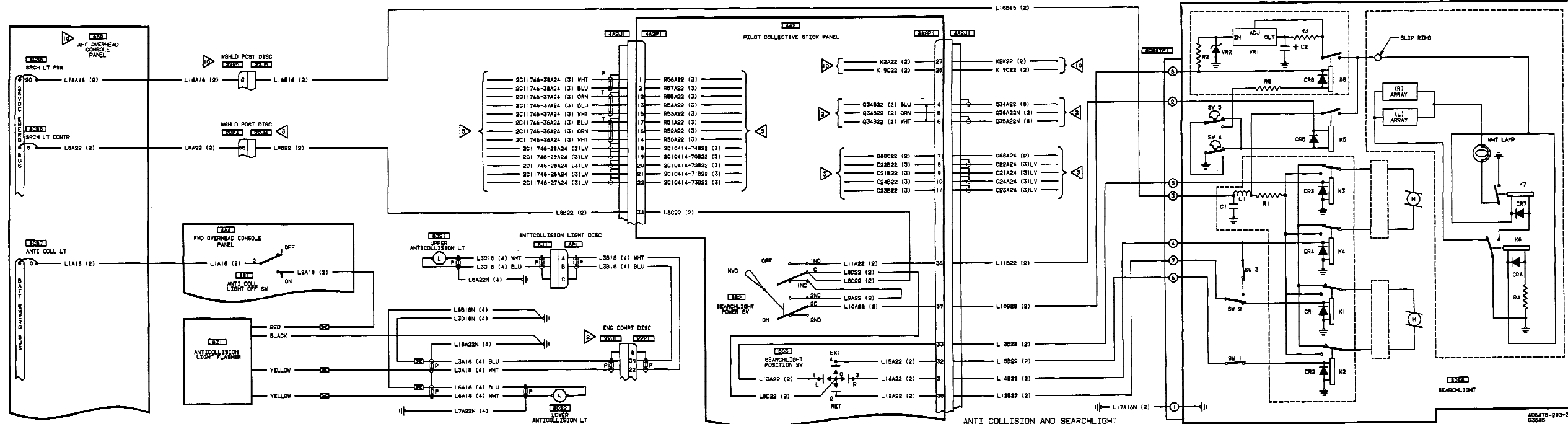

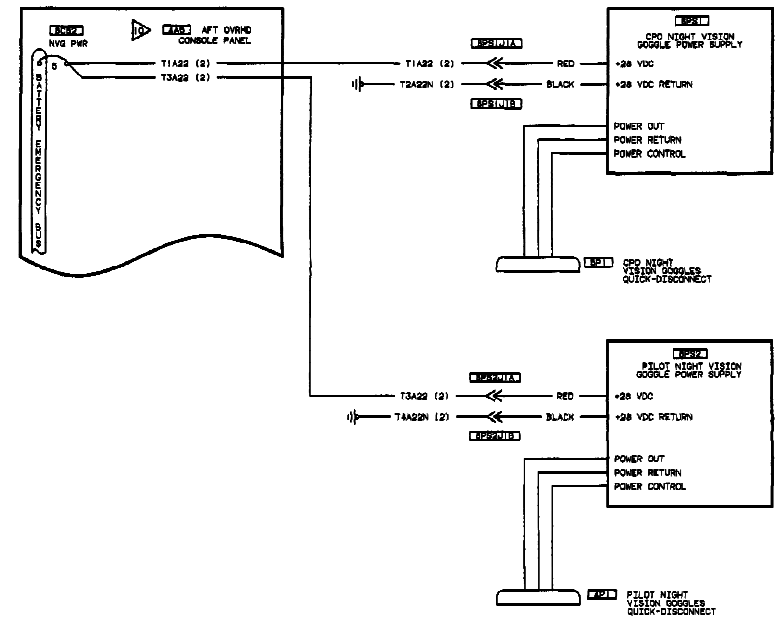

NIGHT VISION GOGGLES LIGHTING

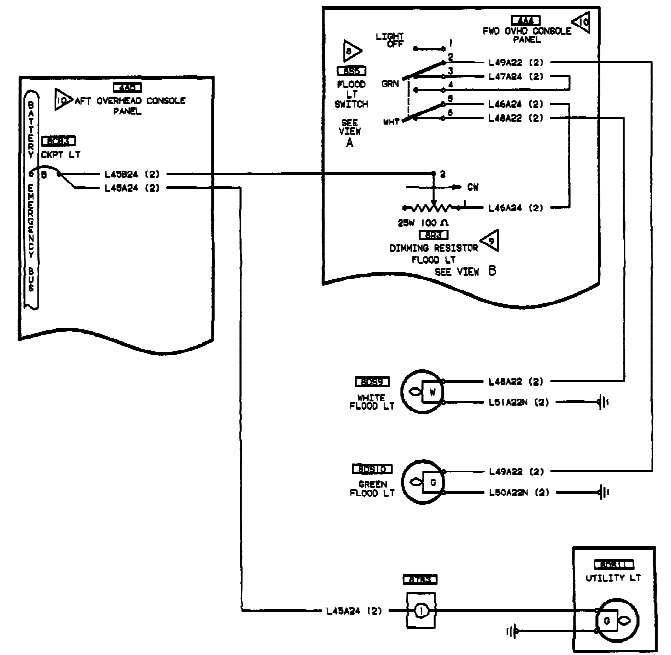

UTILITY AND FLOOD LIGHTING

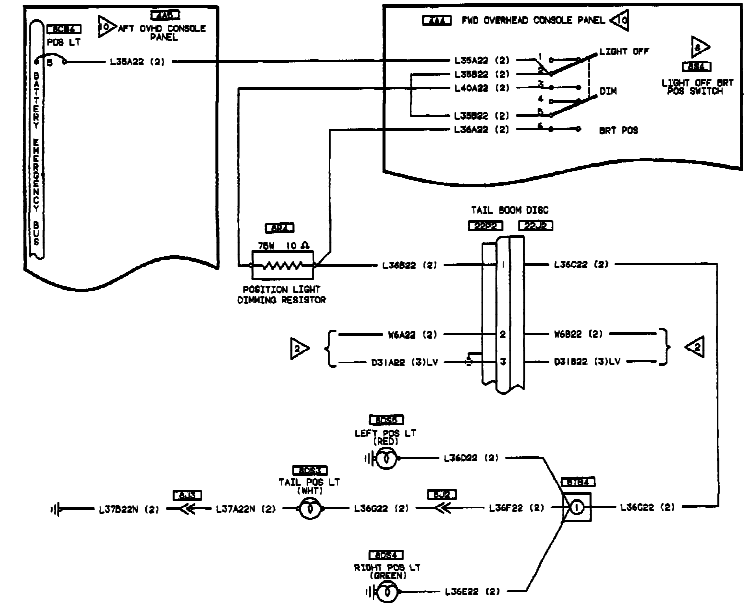

POSITION LIGHTS

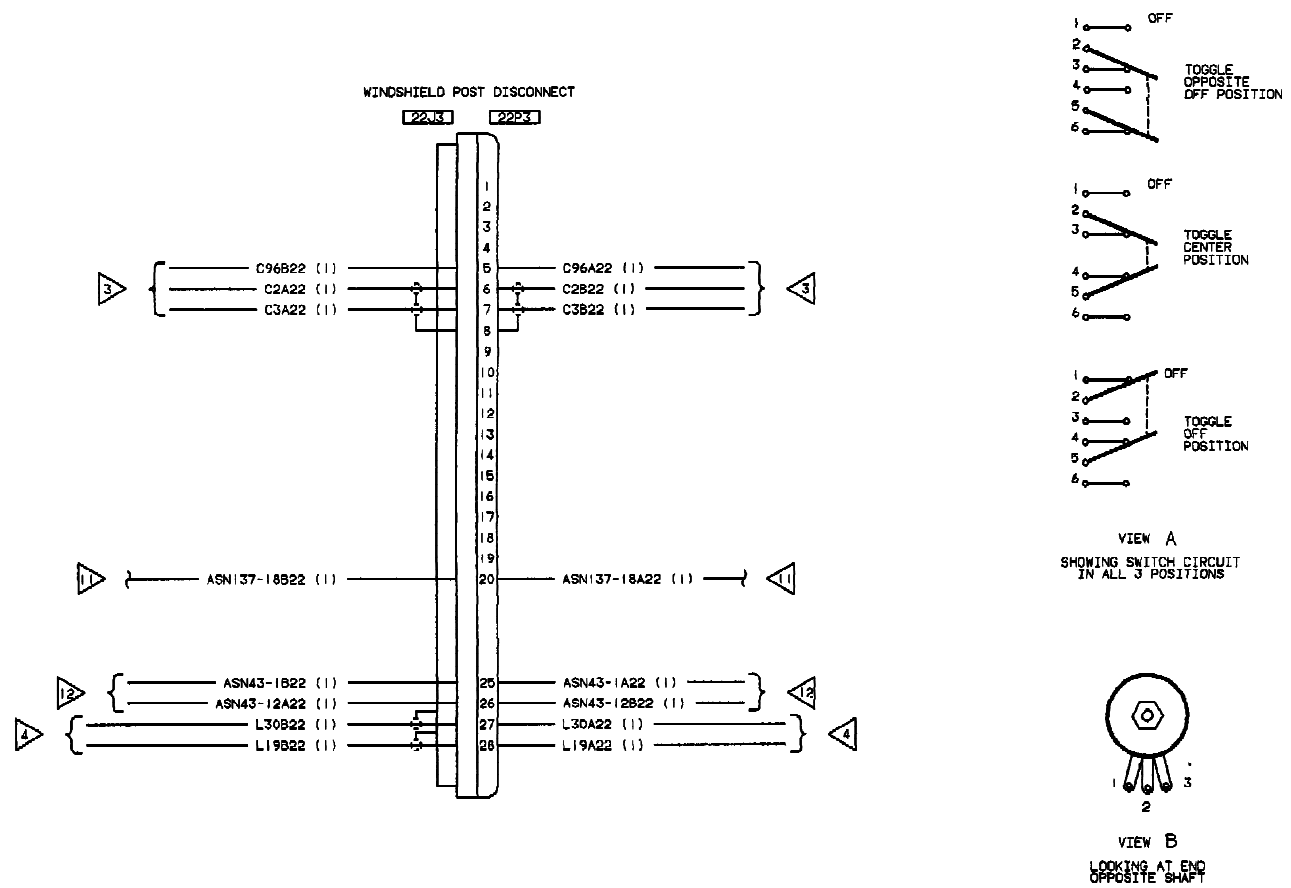

- NOTES**
- 1 REFER TO MMS SYSTEM WIRING DIAGRAM.
  - 2 REFER TO POWER PLANT AND TRANSMISSION SYSTEM WIRING DIAGRAM.
  - 3 REFER TO SCAS, HYDRAULICS SYSTEM WIRING DIAGRAM.
  - 4 REFER TO CDS SYSTEM WIRING DIAGRAM.
  - 5 REFER TO ICS AND ATHS WIRING DIAGRAM, TM 11-1520-248-23.
  - 6 REFER TO RADAR WARNING WIRING DIAGRAM, TM 11-1520-248-23.
  - 7 REFER TO GYROMAGNETIC WIRING DIAGRAM, TM 11-1520-248-23.
  - 8 SEE VIEW A FOR TOGGLE SWITCH POSITIONS.
  - 9 SEE VIEW B FOR TERMINAL CONNECTIONS.
  - 10 REFER TO DC POWER SYSTEM WIRING DIAGRAM.
  - 11 REFER TO DOPPLER WIRING DIAGRAM TM 11-1520-248-23.
  - 12 REFER TO GYROMAGNETIC COMPASS WIRING DIAGRAM TM 11-1520-248-23.
  - 13 MS90335-(1) CONNECTOR TERMINALS SHALL BE IDENTIFIED AS FOLLOWS:
    - 1. POSITIVE CONNECTION (CENTER TERMINAL)
    - 2. NEGATIVE CONNECTION (OUTER TERMINAL)

406475-293-5  
G3665

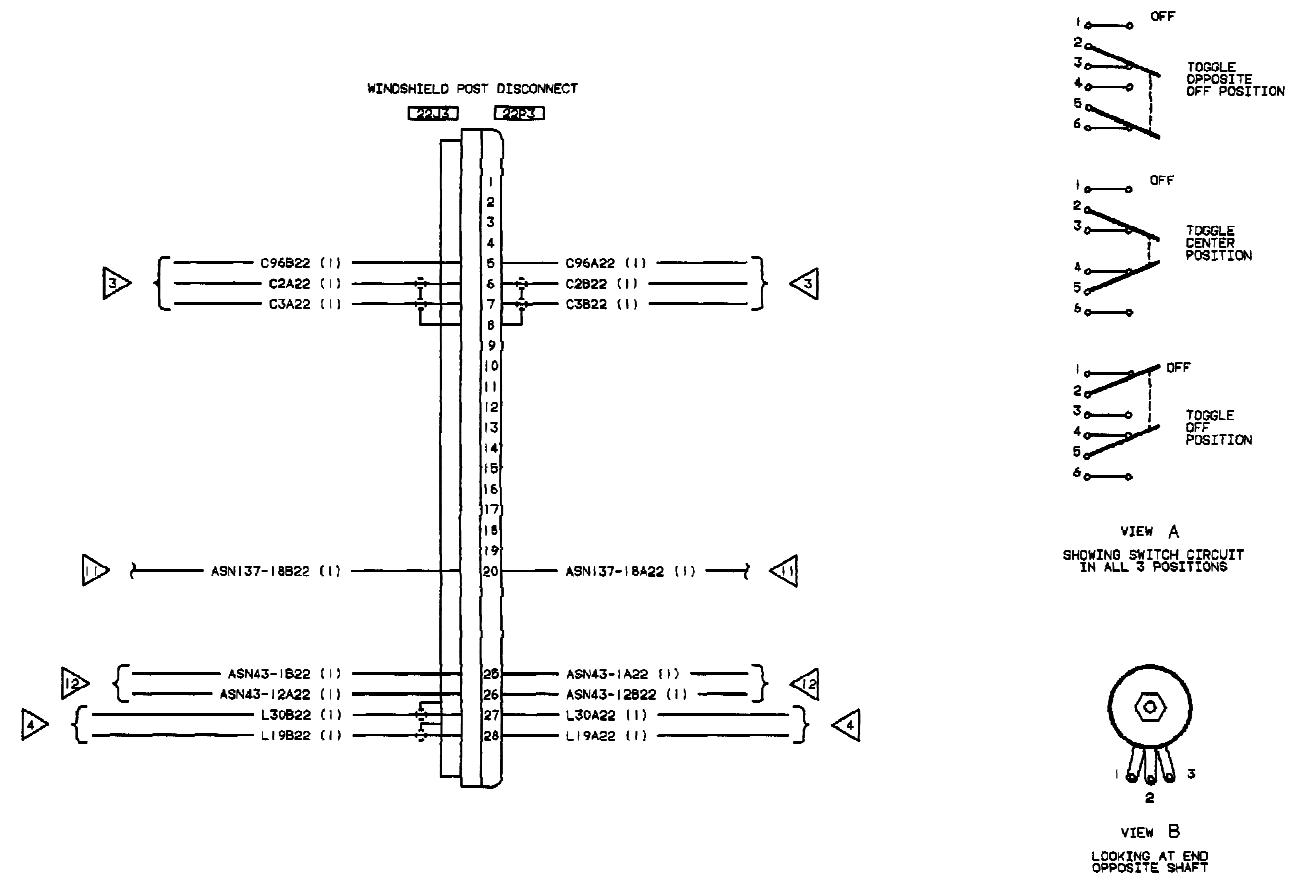

- NOTES**
- 1 REFER TO MMS SYSTEM WIRING DIAGRAM.
  - 2 REFER TO POWER PLANT AND TRANSMISSION SYSTEM WIRING DIAGRAM.
  - 3 REFER TO SCAS, HYDRAULICS SYSTEM WIRING DIAGRAM.
  - 4 REFER TO CDS SYSTEM WIRING DIAGRAM.
  - 5 REFER TO ICS AND ATHS WIRING DIAGRAM, TM 11-1520-248-23.
  - 6 REFER TO RADAR WARNING WIRING DIAGRAM, TM 11-1520-248-23.
  - 7 REFER TO GYROMAGNETIC WIRING DIAGRAM, TM 11-1520-248-23.
  - 8 SEE VIEW A FOR TOGGLE SWITCH POSITIONS.
  - 9 SEE VIEW B FOR TERMINAL CONNECTIONS.
  - 10 REFER TO DC POWER SYSTEM WIRING DIAGRAM.
  - 11 REFER TO DOPPLER WIRING DIAGRAM TM 11-1520-248-23.
  - 12 REFER TO GYROMAGNETIC COMPASS WIRING DIAGRAM TM 11-1520-248-23.
  - 13 MS90335-1 CONNECTOR TERMINALS SHALL BE IDENTIFIED AS FOLLOWS:
    1. POSITIVE CONNECTION (CENTER TERMINAL)
    2. NEGATIVE CONNECTION (OUTER TERMINAL)

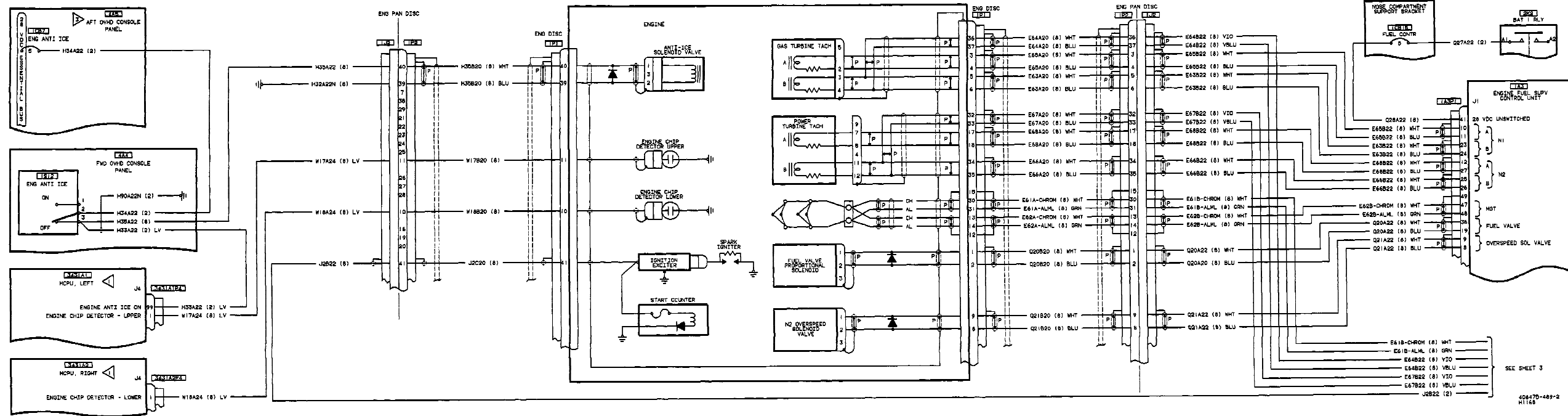

FO-14. Power Plant and Transmission Systems Wiring Diagram (Sheet 2 of 8)





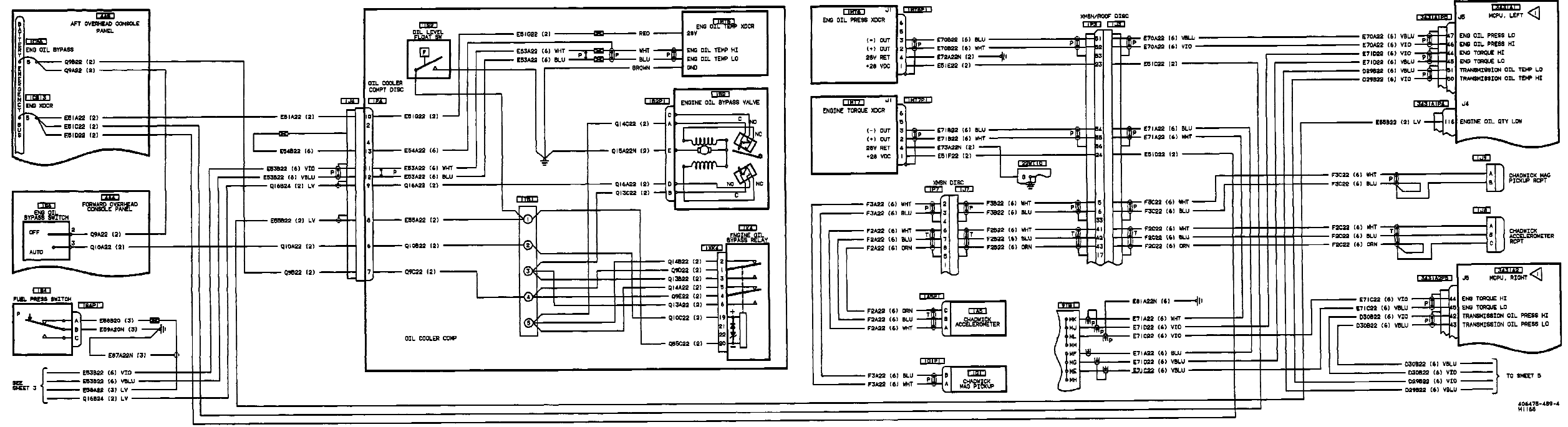

FO-14. Power Plant and Transmission Systems Wiring Diagram (Sheet 4 of 8)

406478-489-4 H1165

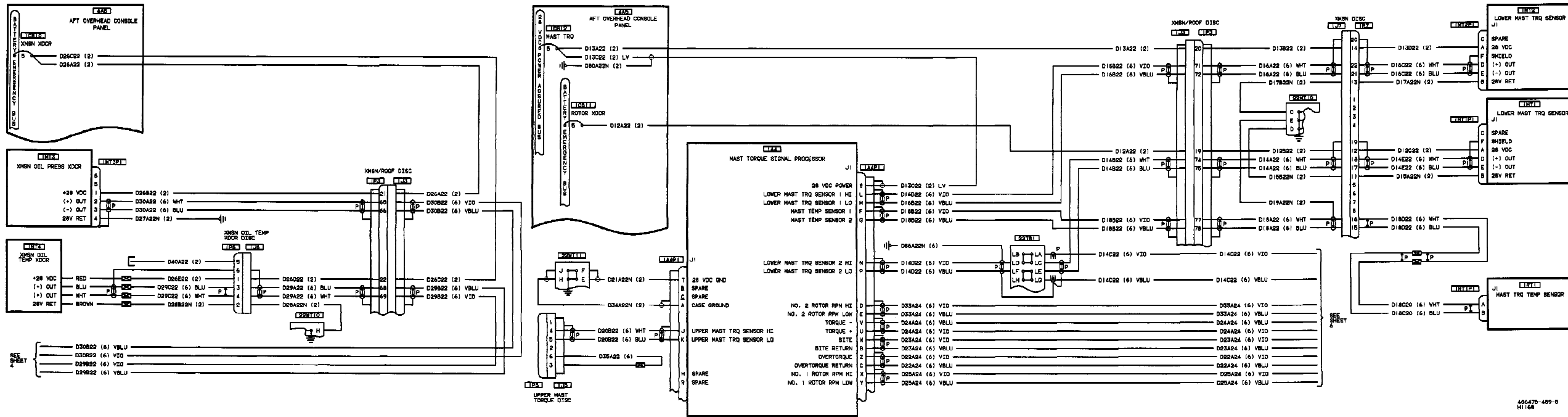

FP-14. Power Plant and Transmission Systems Wiring Diagram (Sheet 5 of 8)

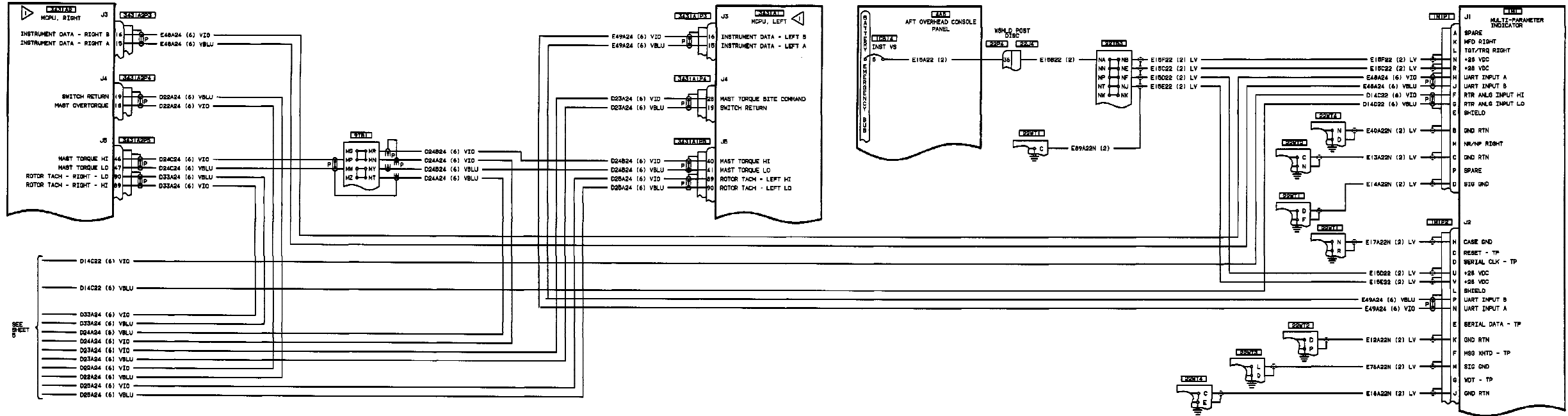

406475-109-8  
HI168

FP-14. Power Plant and Transmission Systems Wiring Diagram (Sheet 6 of 8)



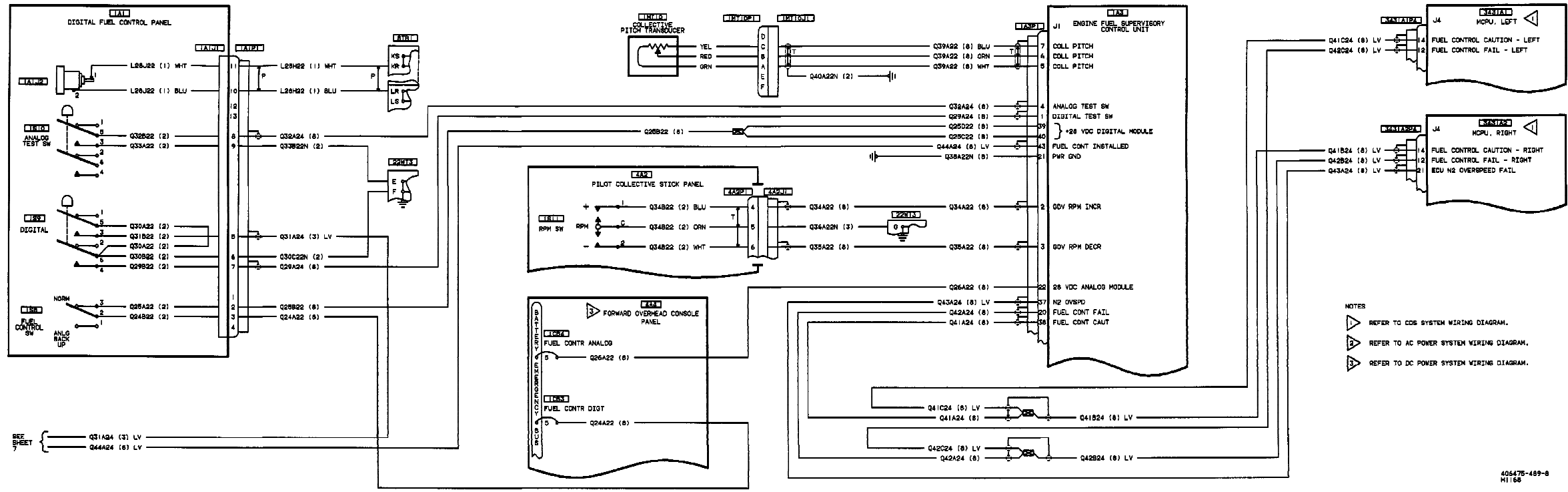

SEE SHEET

FO-14. Power Plant and Transmission Systems Wiring Diagram (Sheet 8 of 8)

406475-489-8  
M1168

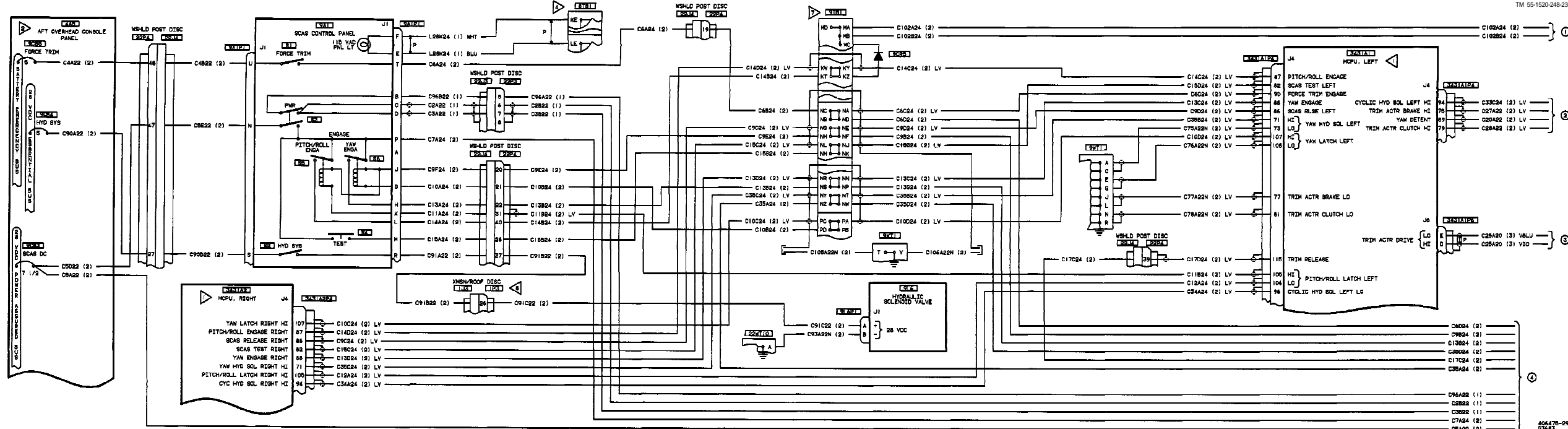

FO-15. SCAS, Hydraulic, and Standby Altitude Gyro System Wiring Diagram (Sheet 1 of 7)

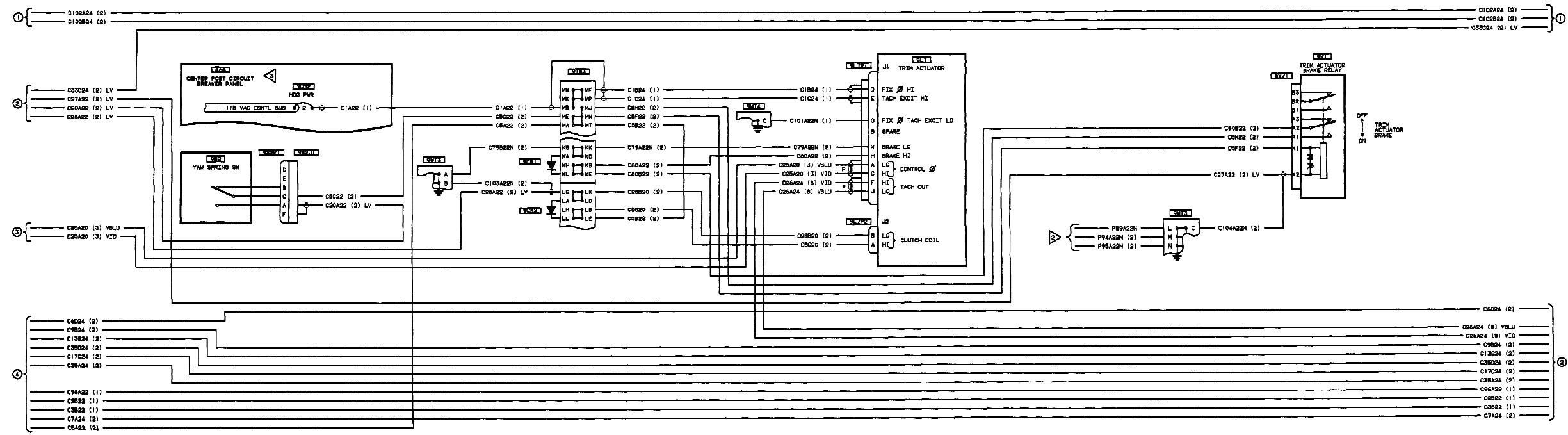

FO-15. SCAS, Hydraulic, and Standby Altitude Gyro System Wiring Diagram (Sheet 2 of 7)

406479-294-2  
09465







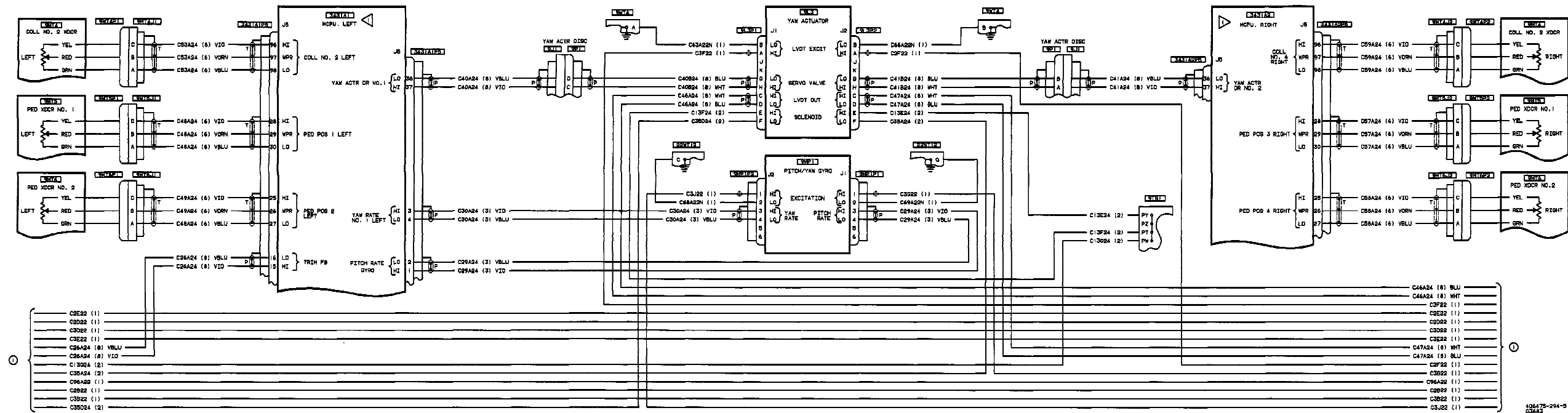

FO-15. SCAS, Hydraulic, and Standby Altitude Gyro System Wiring Diagram (Sheet 5 of 7)

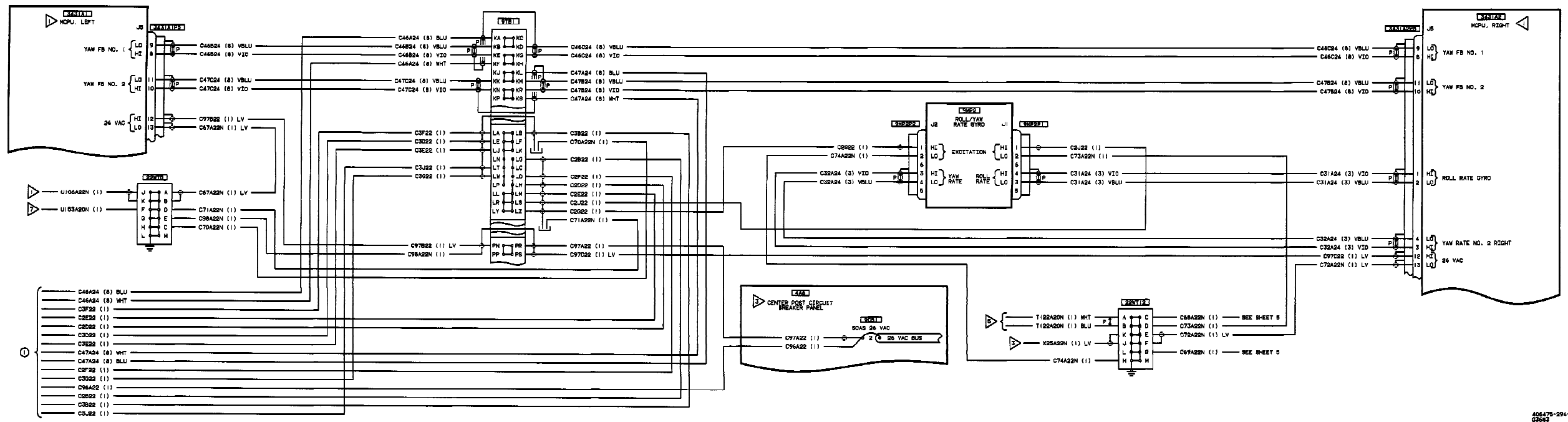

FO-15. SCAS, Hydraulic, and Standby Altitude Gyro System Wiring Diagram (Sheet 6 of 7)

406475-294-6  
C3643

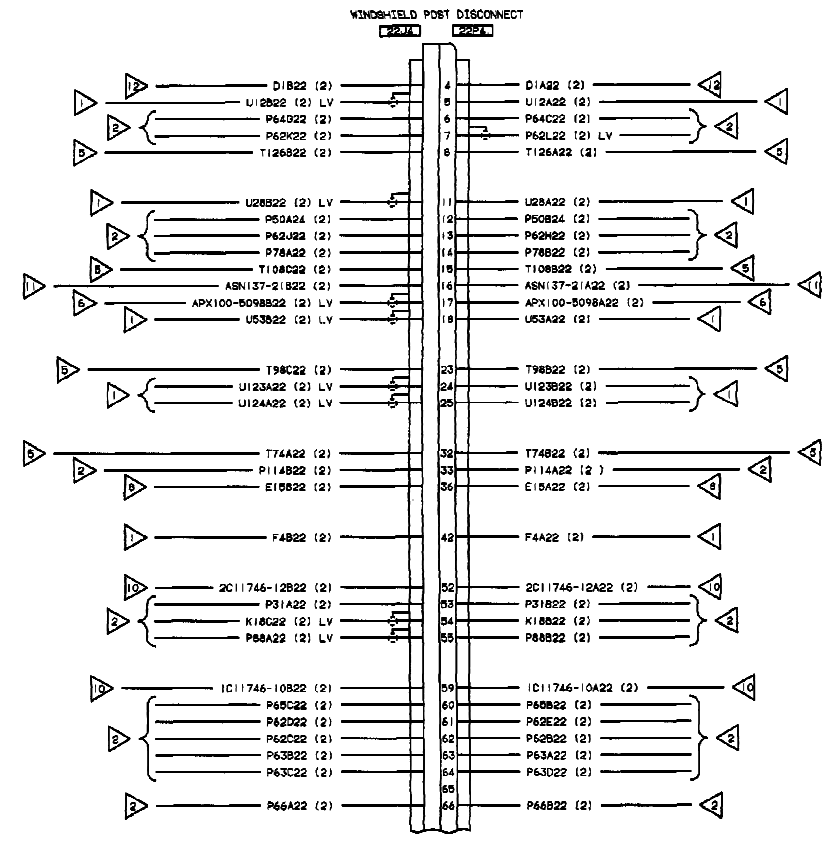
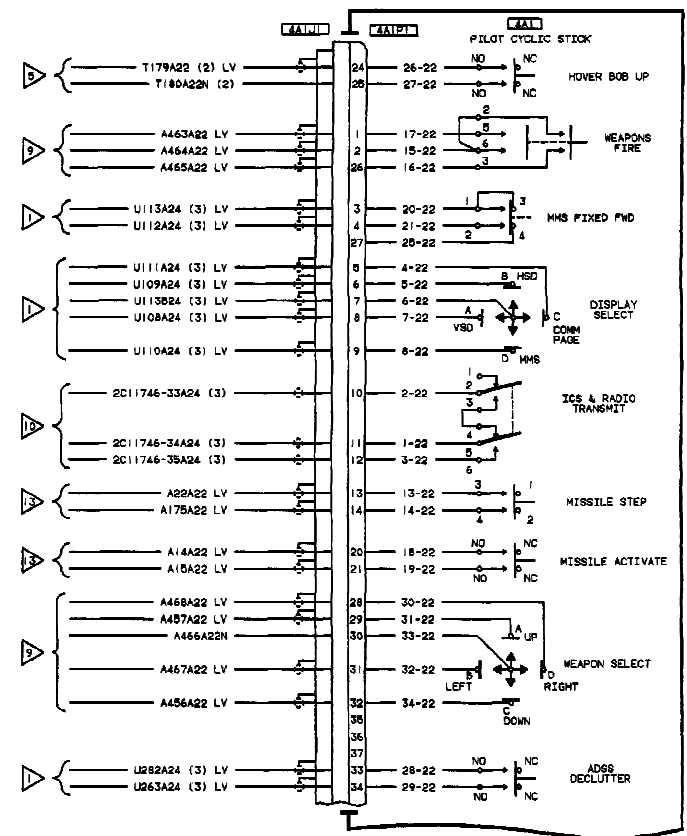

NOTES

- 1 REFER TO CDS SYSTEM WIRING DIAGRAM.
- 2 REFER TO DC POWER SYSTEM WIRING DIAGRAM.
- 3 REFER TO AC POWER SYSTEM WIRING DIAGRAM.
- 4 REFER TO LIGHTING SYSTEM WIRING DIAGRAM.
- 5 REFER TO HHS SYSTEM WIRING DIAGRAM.
- 6 REFER TO AN/APX100 IFF SYSTEM WIRING DIAGRAM TM 11-1520-248-23.
- 7 REFER TO AHRS SYSTEM WIRING DIAGRAM TM 11-1520-248-23.
- 8 REFER TO POWER PLANT AND TRANSMISSION WIRING DIAGRAM.
- 9 REFER TO GUNS AND ROCKETS SYSTEM WIRING DIAGRAM.
- 10 REFER TO ICS WIRING DIAGRAM TM 11-1520-248-23.
- 11 REFER TO DOPPLER NAVIGATION WIRING DIAGRAM TM 11-1520-248-23.
- 12 REFER TO ADS WIRING DIAGRAM.
- 13 REFER TO ATAS WIRING DIAGRAM.

14 NUMBERED CIRCLE ON RIGHT SIDE OF SHEET SIGNIFIES "GO TO NEXT SHEET" AND FIND SAME NUMBER ON LEFT SIDE OF SHEET WITH MATCHING WIRE NUMBER(S).

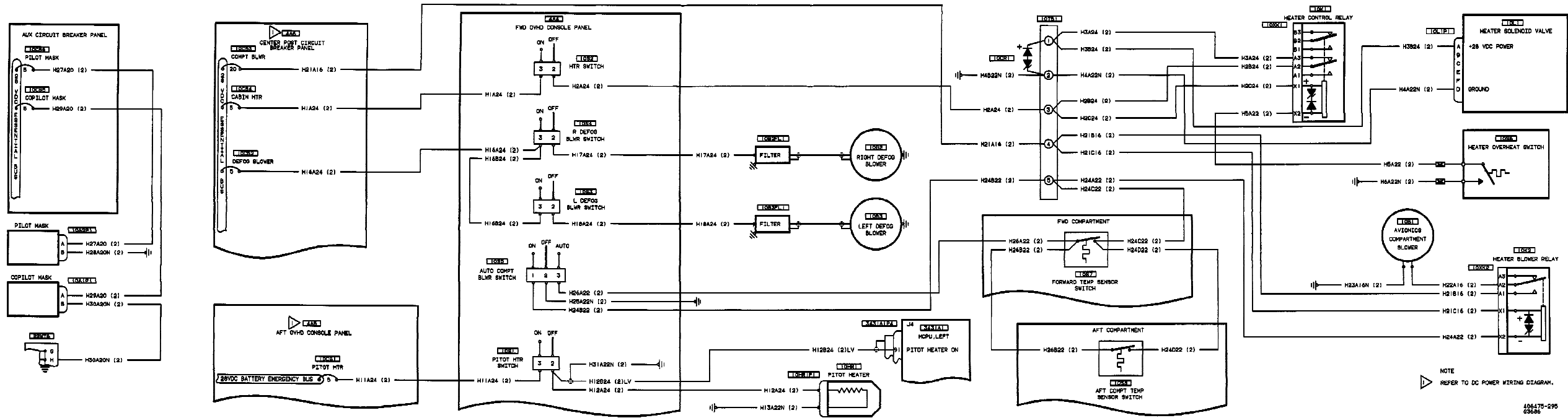

FO-16. Environmental Electrical System Wiring Diagram

406475-295  
63686



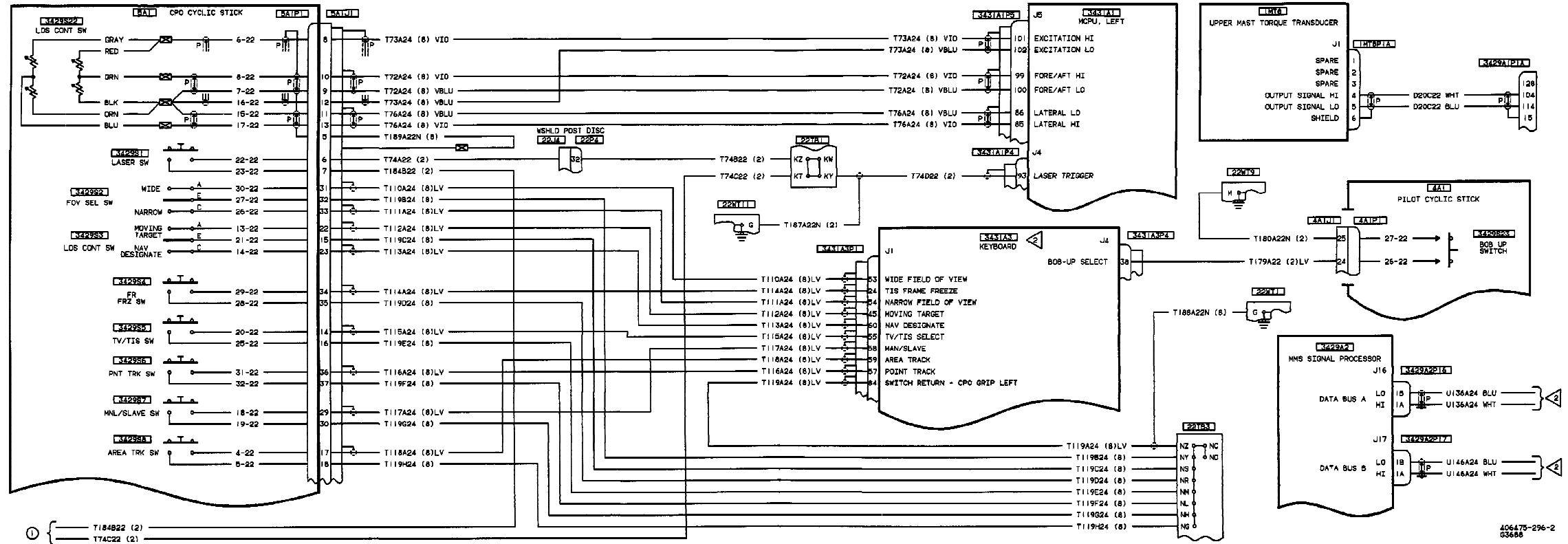

406475-296-2  
53686

FO-17. Mast Mounted Sight (MMS) System Wiring Diagram (Sheet 2 of 4)





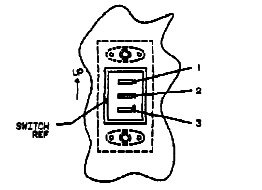
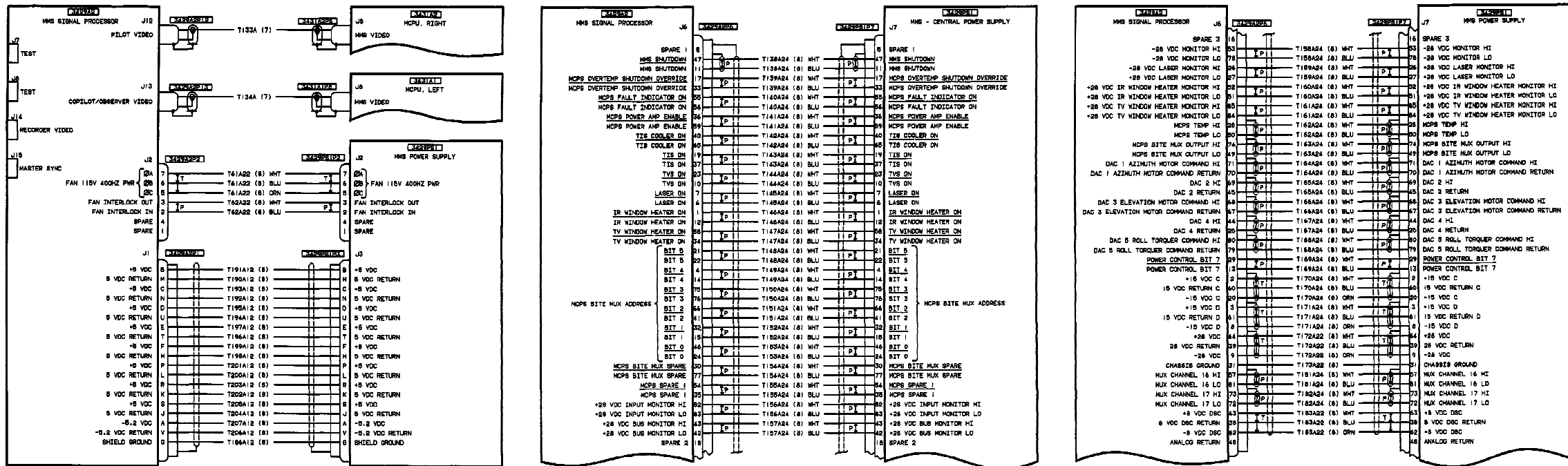

VIEW LOOKING AT REAR OF SWITCH AS INSTALLED IN PANEL TO SHOW SWITCH TERMINAL (1), (2), OR (3) IDENTIFICATION.

- NOTES
- 1. REFER TO POWER PLANT AND TRANSMISSION SYSTEM WIRING DIAGRAM.
  - 2. REFER TO ODS SYSTEM WIRING DIAGRAM.
  - 3. REFER TO DC POWER SYSTEM WIRING DIAGRAM.
  - 4. REFER TO AC POWER SYSTEM WIRING DIAGRAM.
  - 5. REFER TO LIGHTING SYSTEM WIRING DIAGRAM.
  - 6. FURNISHED CONNECTOR CONTACT IDENTIFICATION FOR TERMINATING A 3-CONDUCTOR SHIELDED JACKETED CABLE SHALL BE AS FOLLOWS:  
P = PIN CONTACT  
S = SOCKET CONTACT
  - 7. SEE VIEW A FOR SWITCH TERMINAL IDENTIFICATION.
  - 8. VIEW LOOKING AT REAR OF CIRCUIT BREAKER, NUMBERS WILL READ FROM LEFT TO RIGHT WITH 1, 2, AND 3 ON THE TOP, OR REAR SIDE.
  - 9. NUMBERED CIRCLE ON RIGHT SIDE OF SHEET IDENTIFIES "GO TO NEXT SHEET" AND FIND SAME NUMBER ON LEFT SIDE OF SHEET WITH MATCHING WIRE NUMBER(S).

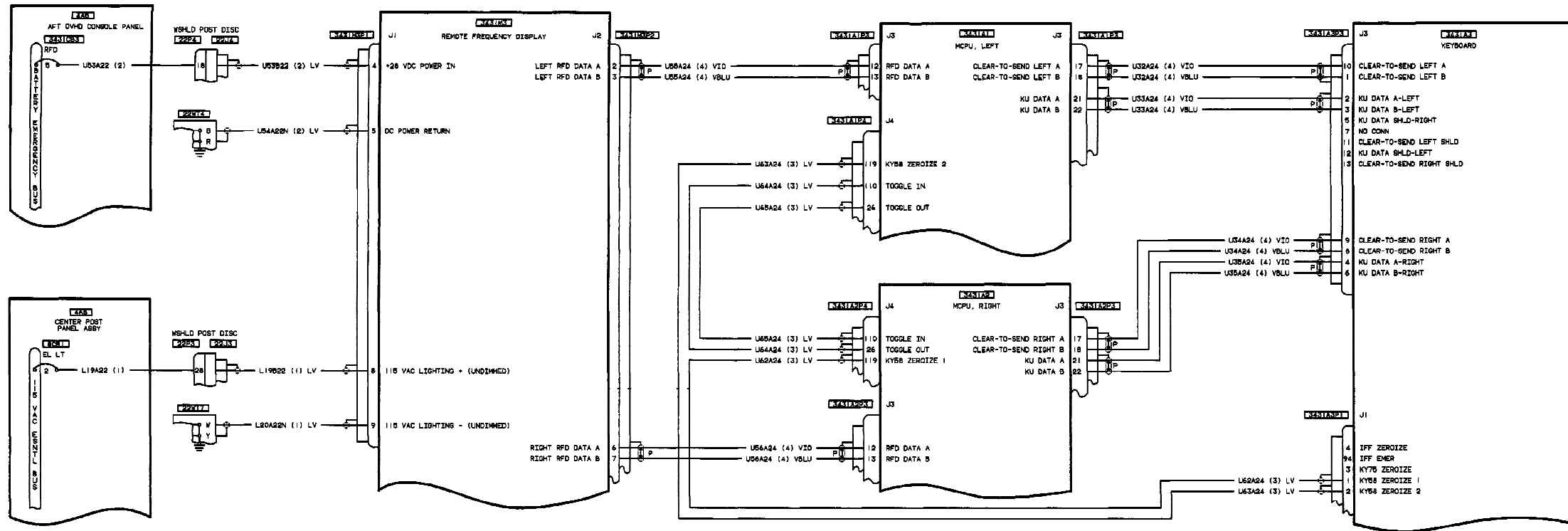

FO-18. Control Display System (CDS) Wiring Diagram (Sheet 1 of 10)

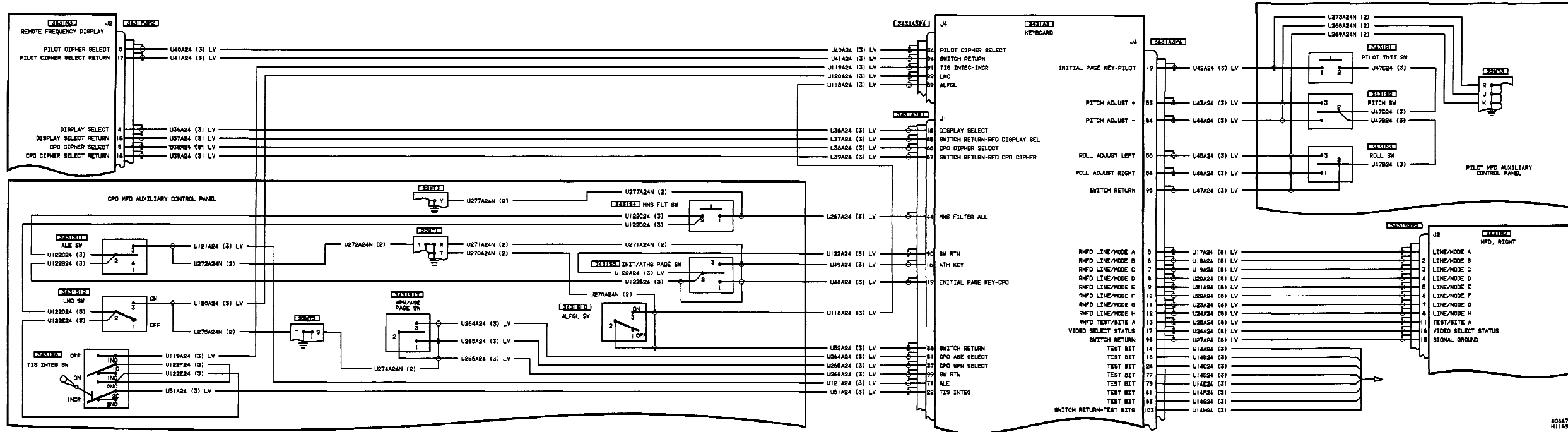

FO-18. Control Display System (CDS) Wiring Diagram (Sheet 2 of 10)

006675-1179-2  
H165



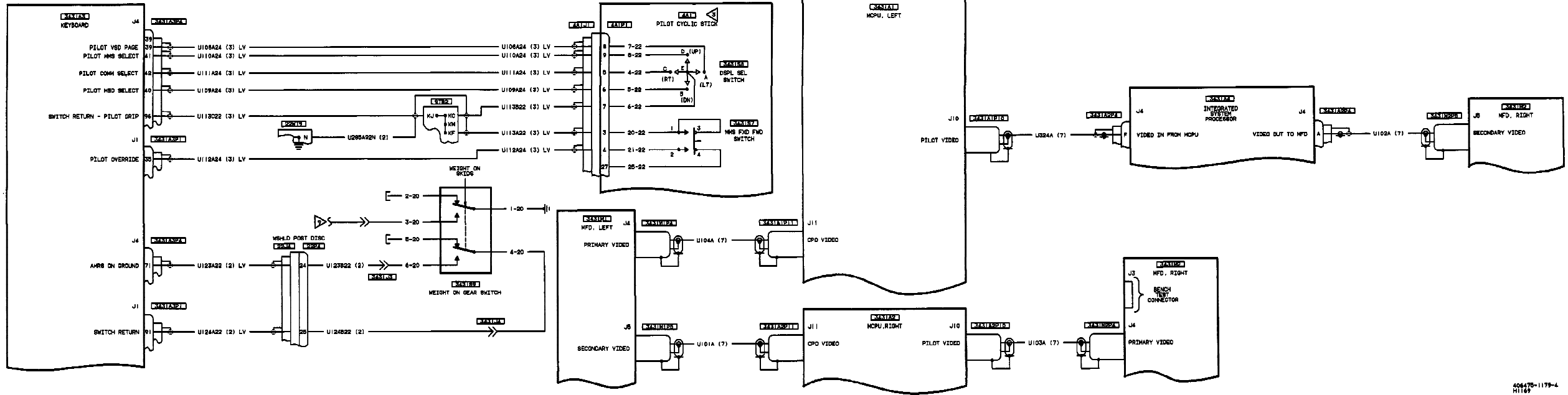

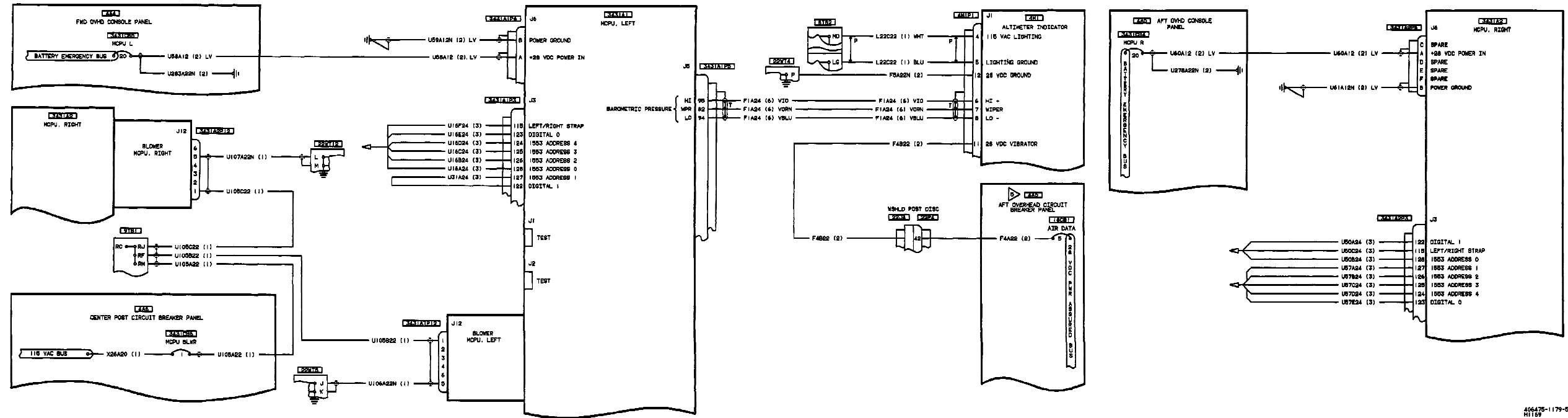

FO-18. Control Display System (CDS) Wiring Diagram (Sheet 5 of 10)

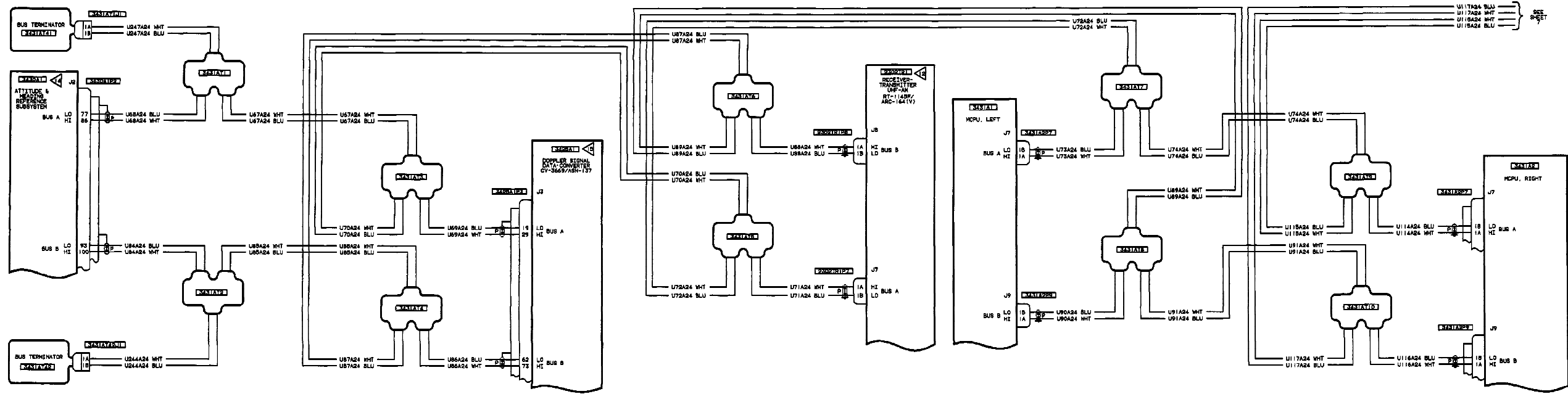

FO-18. Control Display System (CDS) Wiring Diagram (Sheet 6 of 10)





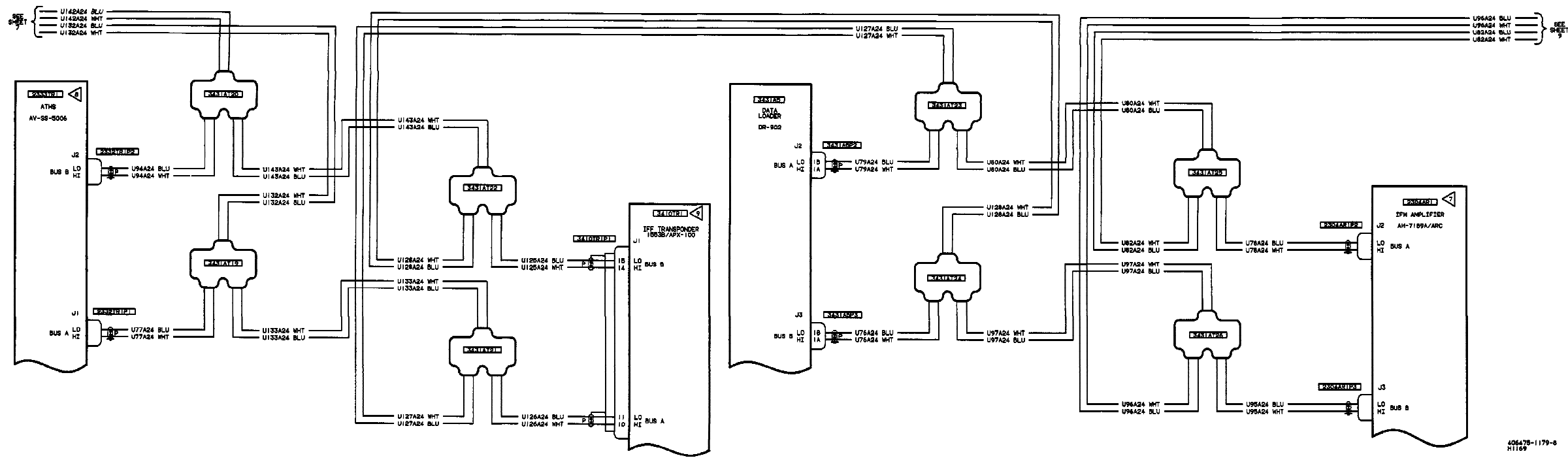

FO-18. Control Display System (CDS) Wiring Diagram (Sheet 8 of 10)



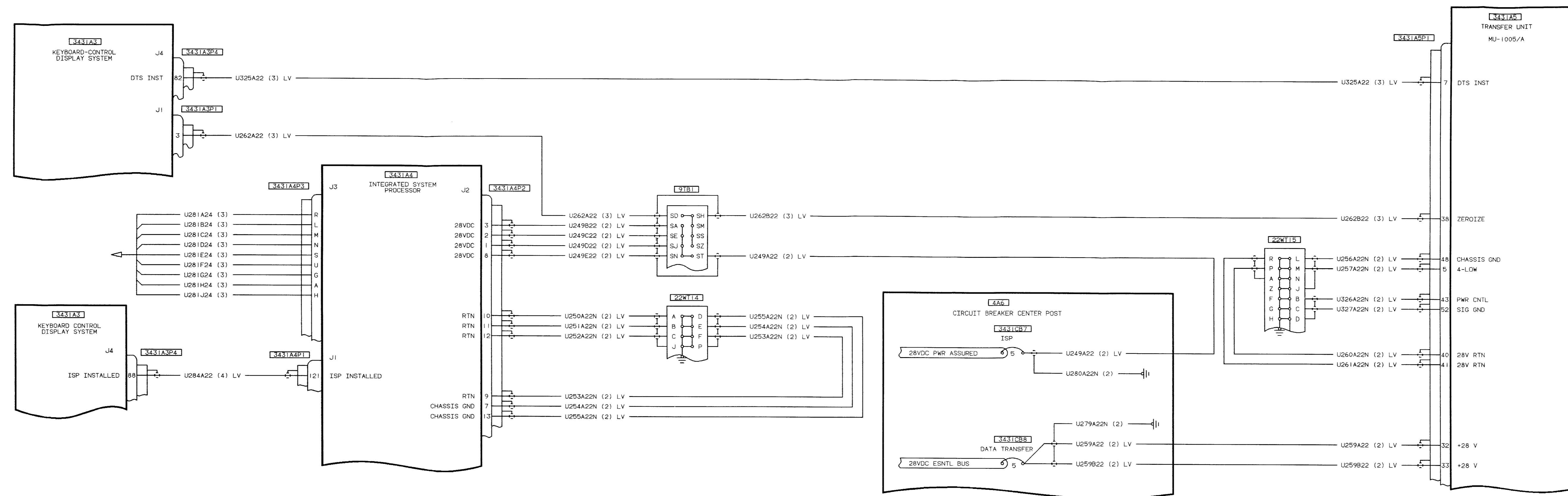

- NOTES
- 1 REFER TO AN/APR-44 RADAR DETECTOR WIRING DIAGRAM.
  - 2 REFER TO AC POWER SYSTEM WIRING DIAGRAM.
  - 3 REFER TO FIGHT CONTROL AND HYDRAULIC SYSTEM WIRING DIAGRAM.
  - 4 REFER TO VIDEO TAPE RECORDER WIRING DIAGRAM.
  - 5 REFER TO AIR DATA SUBSYSTEM WIRING DIAGRAM.
  - 6 REFER TO NO. 2 VHF-FM WIRING DIAGRAM.
  - 7 REFER TO NO. 1 VHF-FM WIRING DIAGRAM.
  - 8 REFER TO INTERCOM AND ATH SYSTEMS WIRING DIAGRAM.
  - 9 REFER TO IFF (AN/APX-100) WIRING DIAGRAM.
  - 10 REFER TO MAST MOUNTED SIGHT WIRING DIAGRAM.
  - 11 REFER TO HF COMM SYSTEM (AN/ARC-199) WIRING DIAGRAM.
  - 12 REFER TO UHF-AM COMM (AN/ARC-164) WIRING DIAGRAM.
  - 13 REFER TO VHF-AM COMM (AN/ARC-186) WIRING DIAGRAM.
  - 14 REFER TO ATTITUDE AND HEADING REFERENCE SYSTEM WIRING DIAGRAM.
  - 15 REFER TO DOPPLER NAV SYSTEM (AN/ASN-137) WIRING DIAGRAM.
  - 16 REFER TO LIGHTING SYSTEM WIRING DIAGRAM.

FO-18. Control Display System (CDS) Wiring Diagram (Sheet 10 of 10)

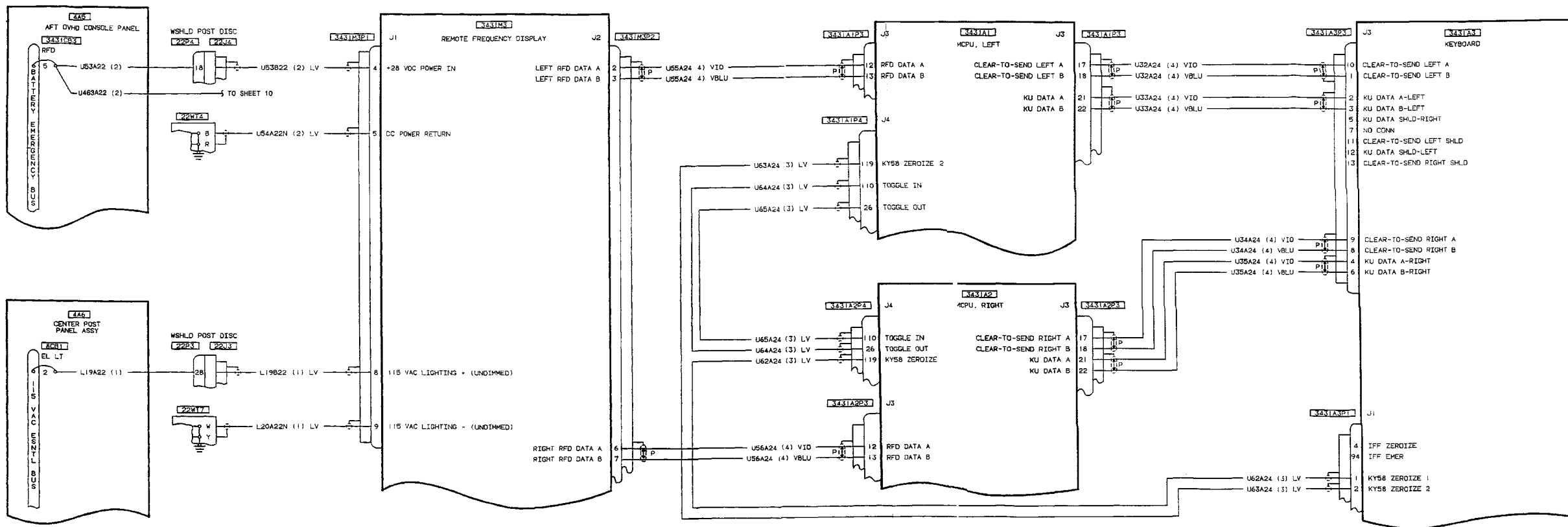

Figure FO-18.1. Control Display System (CDS) Wiring Diagram (With EGI System) (Sheet 1 of 10)

Change 5 FP-174.1/(FP-174.2 blank)

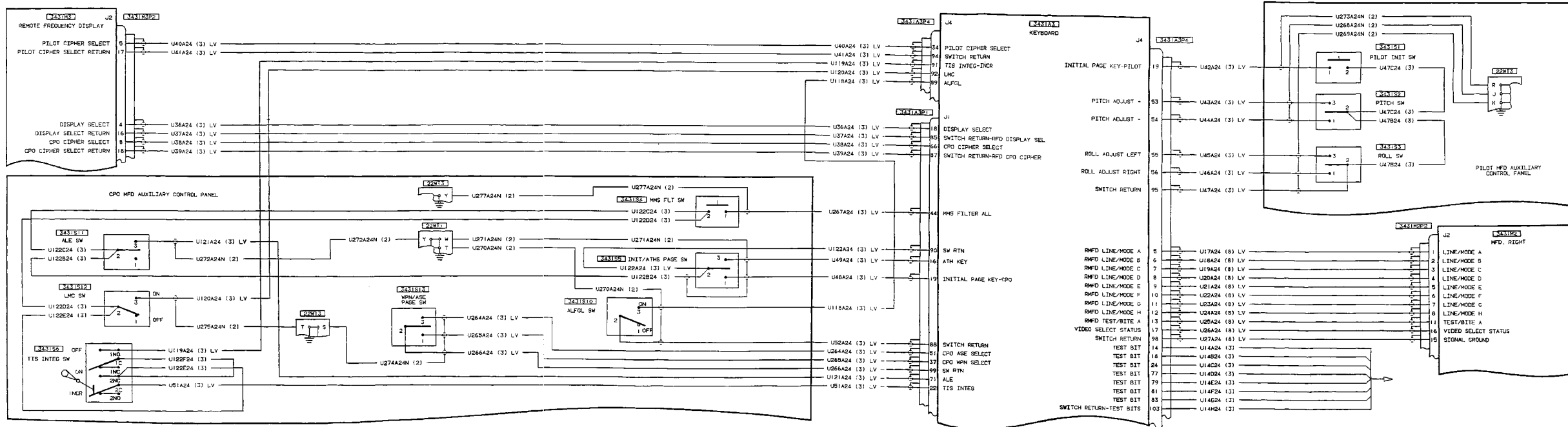

Figure FO-18.1. Control Display System (CDS) Wiring Diagram (With EGI System) (Sheet 2 of 10)

Change 5 FP-174.3/(FP-174.4 blank)



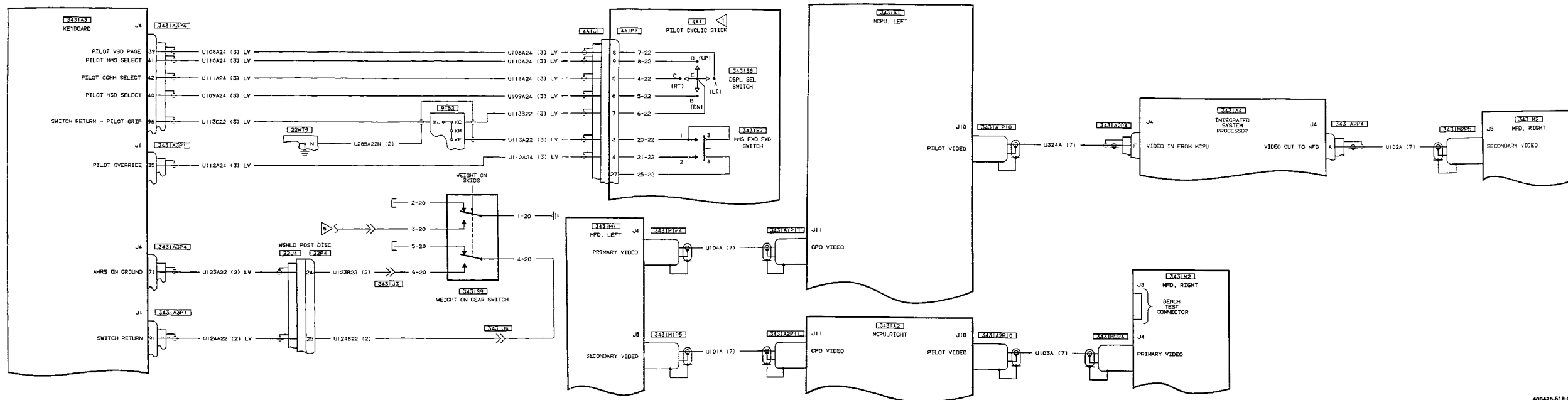
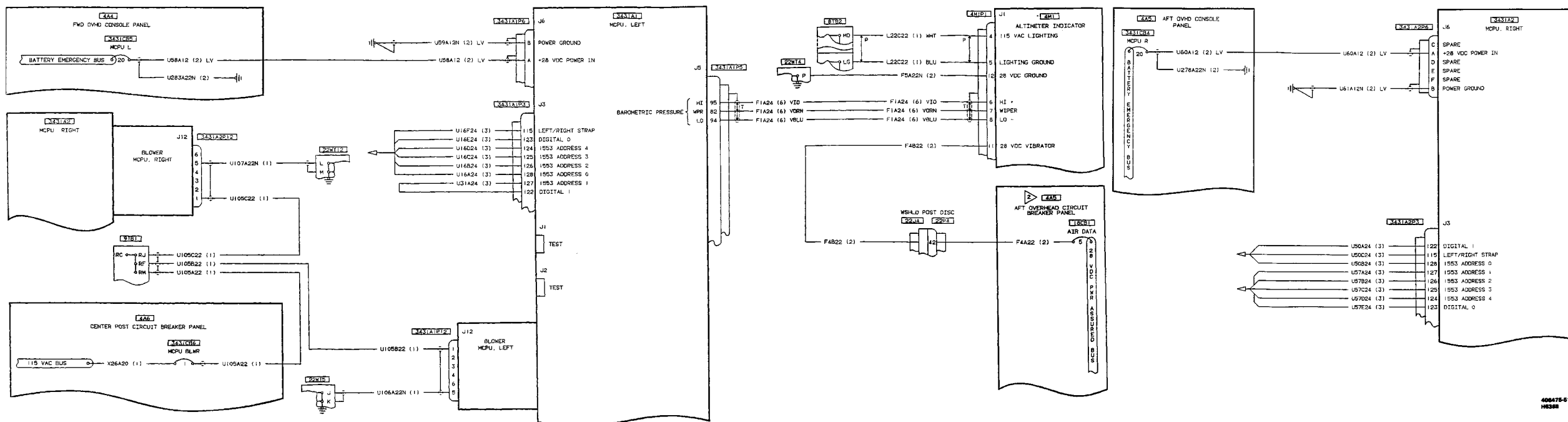

Figure FO-18.1. Control Display System (CDS) Wiring Diagram (With EGI System) (Sheet 4 of 10)

Change 5 FP-174.7/(FP-174.8 blank)



400475-518-5  
H5358

Figure FO-18.1. Control Display System (CDS) Wiring Diagram (With EGI System) (Sheet 5 of 10)

Change 5 FP-174.9/(FP-174.10 blank)



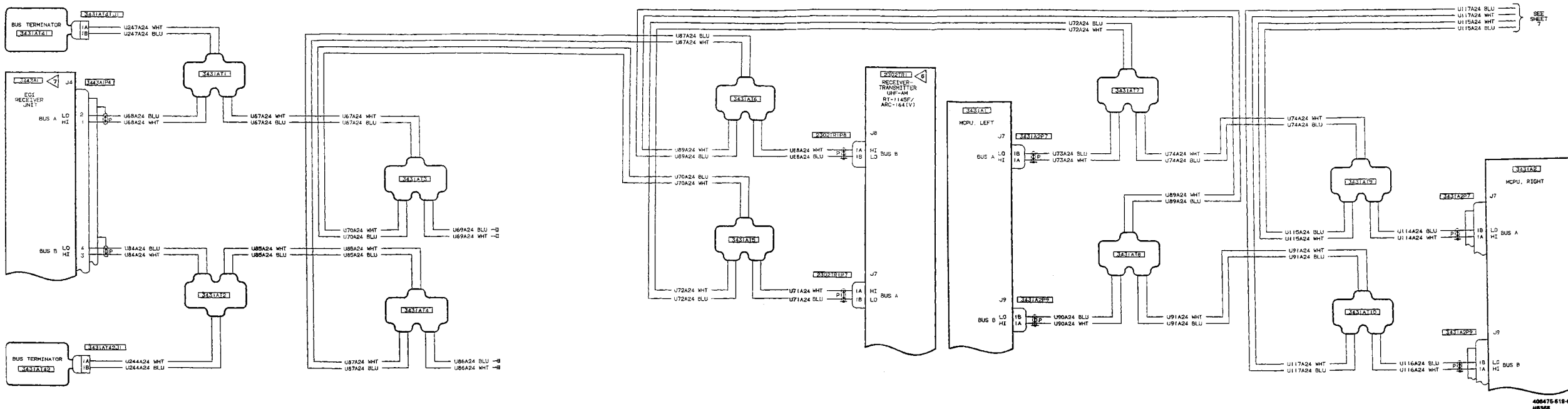

Figure FO-18.1. Control Display System (CDS) Wiring Diagram (With EGI System) (Sheet 6 of 10).

Change 5 FP-174.11/(FP-174.12 blank)

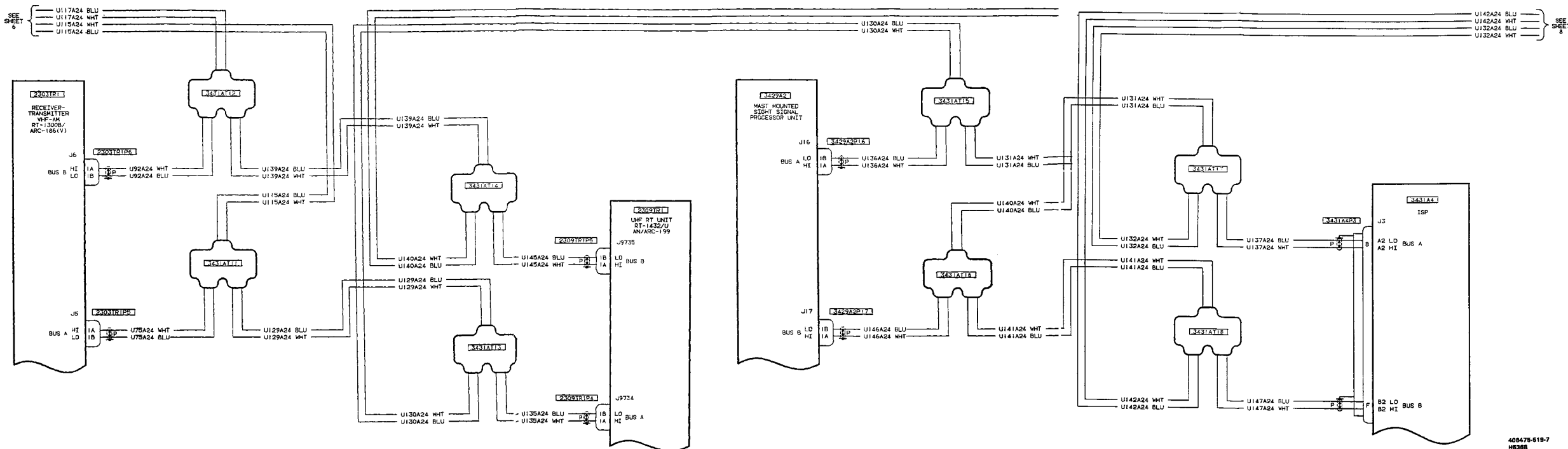

Figure FO-18.1. Control Display System (CDS) Wiring Diagram (With EGI System) (Sheet 7 of 10).

Change 5 FP-174.13/(FP-174.14 blank)

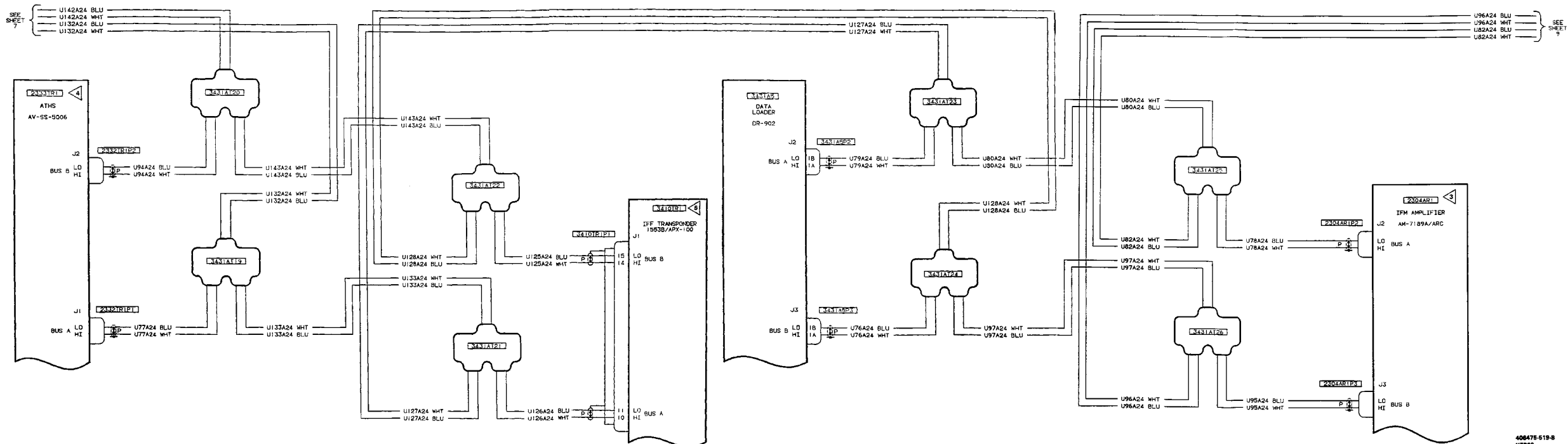

Figure FO-18.1. Control Display System (CDS) Wiring Diagram (With EGI System) (Sheet 8 of 10).

Change 5 FP-174.15/(FP-174.16 blank)

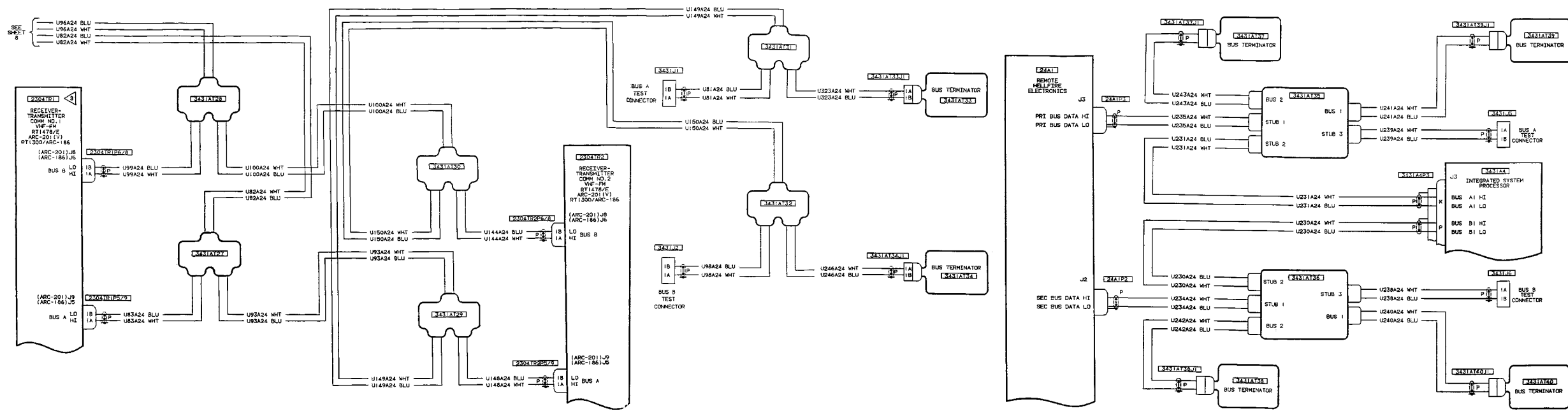
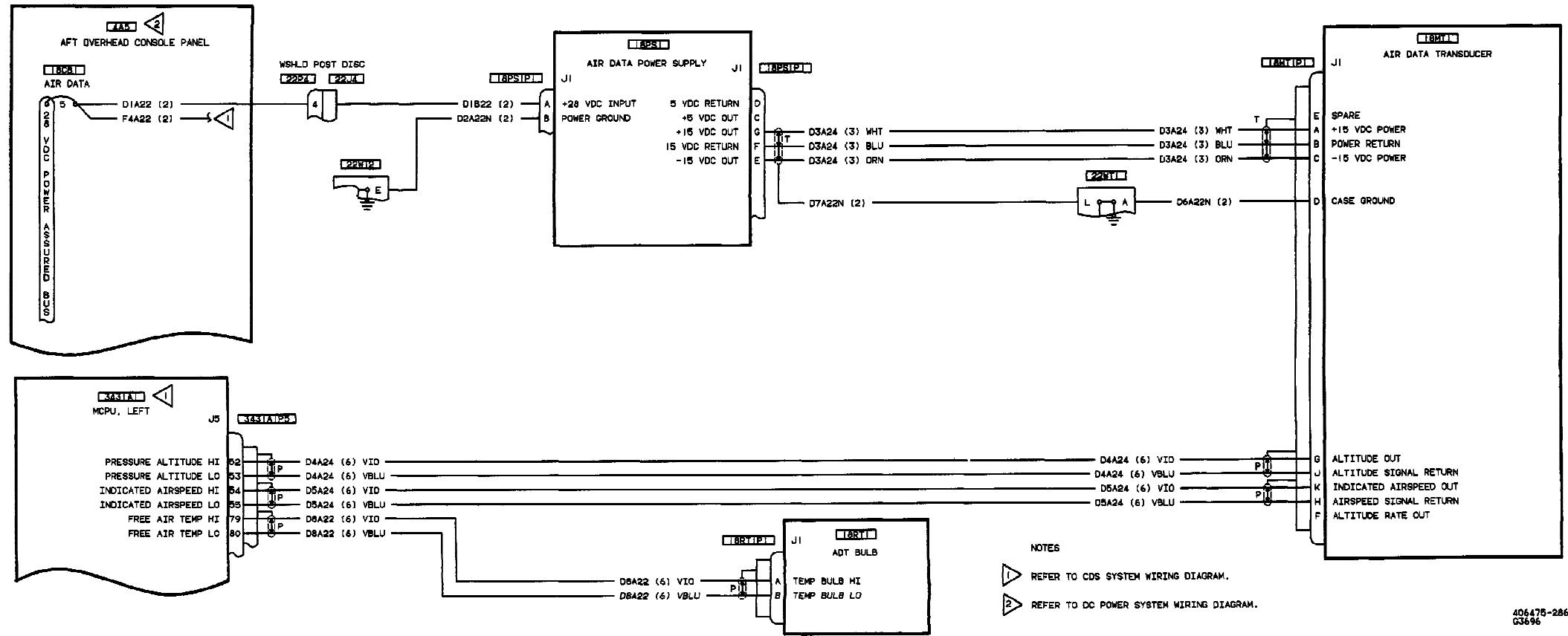

Figure FO-18.1. Control Display System (CDS) Wiring Diagram (With EGI System) (Sheet 9 of 10).

Change 5 FP-174.17/(FP-174.18 blank)







405475-286  
G3696

FO-20. Air Data Systems (ADS) Wiring Diagram

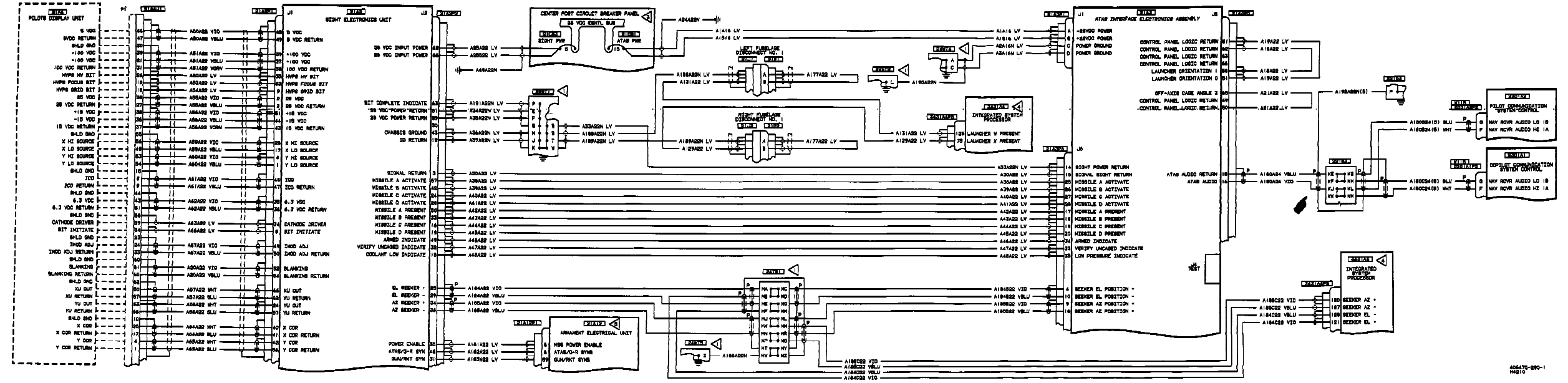



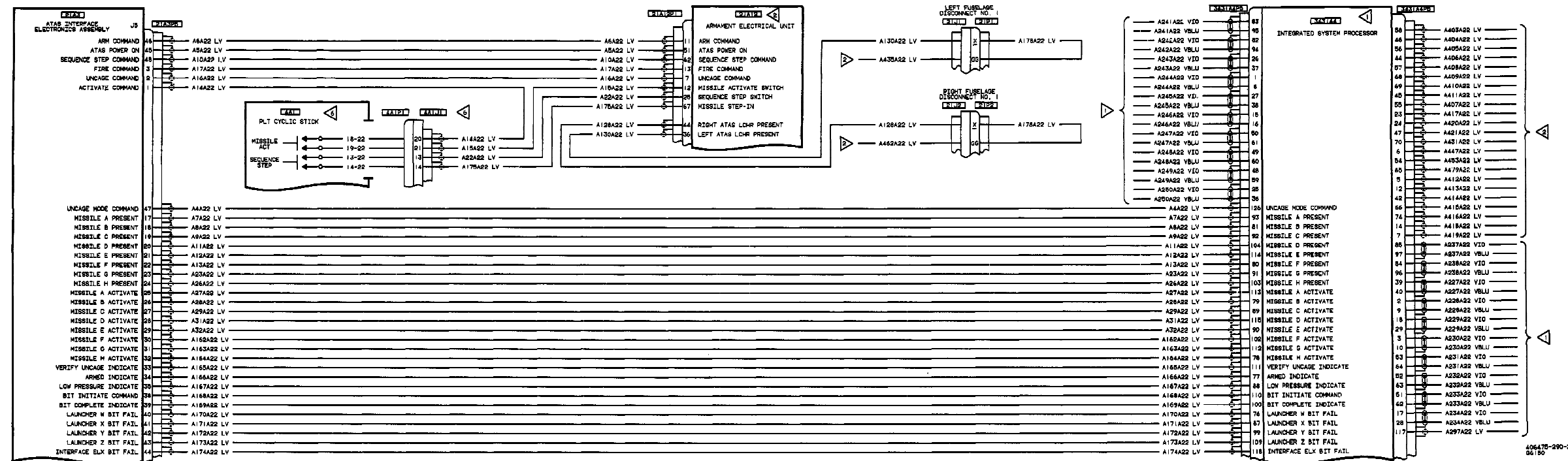

FO-21. Air-to-Air Stringer (ATAS) Missile System Wiring Diagram (Sheet 2 of 3)

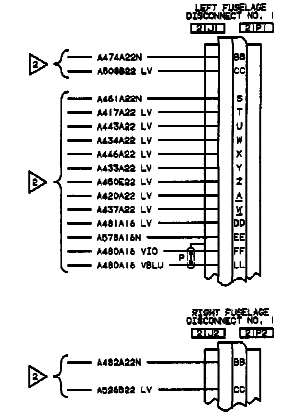
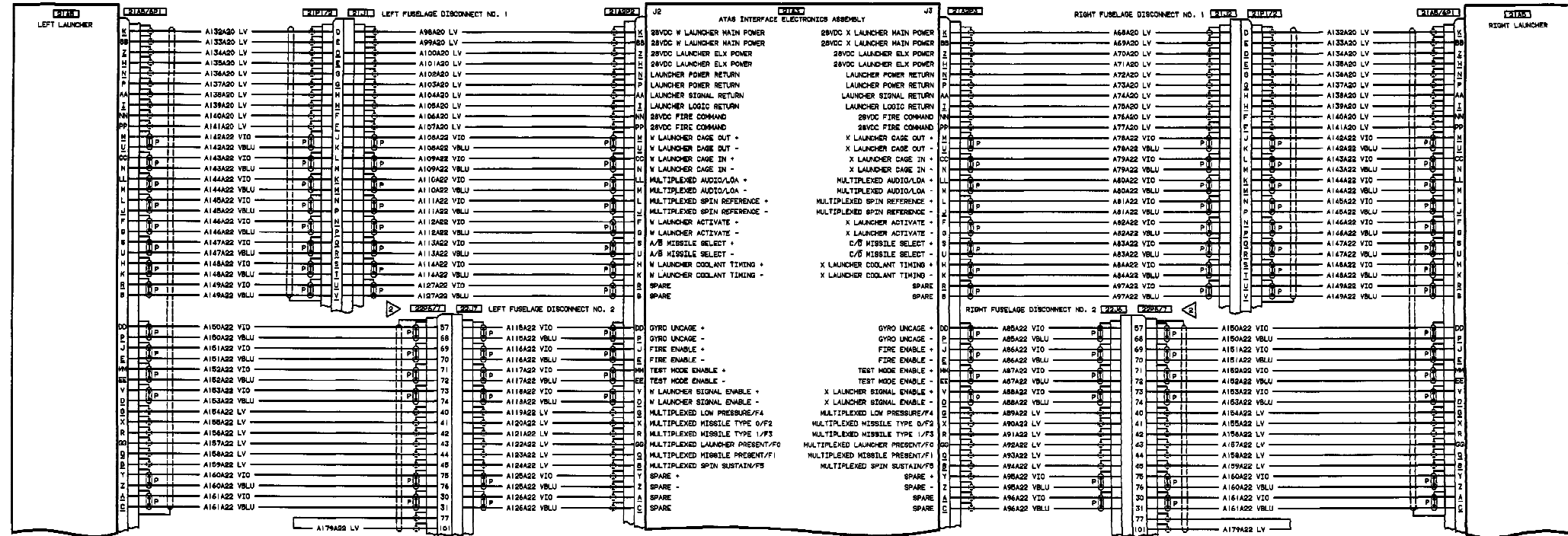

- NOTES
- REFER TO HELLFIRE SYSTEM WIRING DIAGRAM.
  - REFER TO GUN AND ROCKETS WIRING DIAGRAM.
  - REFER TO DC POWER SYSTEM WIRING DIAGRAM.
  - REFER TO CDS SYSTEM WIRING DIAGRAM.
  - REFER TO ICS SYSTEM WIRING DIAGRAM TM 11-1520-248-23.
  - REFER TO SCAS AND HYDRAULICS WIRING DIAGRAM.

FO-21. Air-to-Air Stringer (ATAS) Missile System Wiring Diagram (Sheet 3 of 3)

404475-290-3  
06150

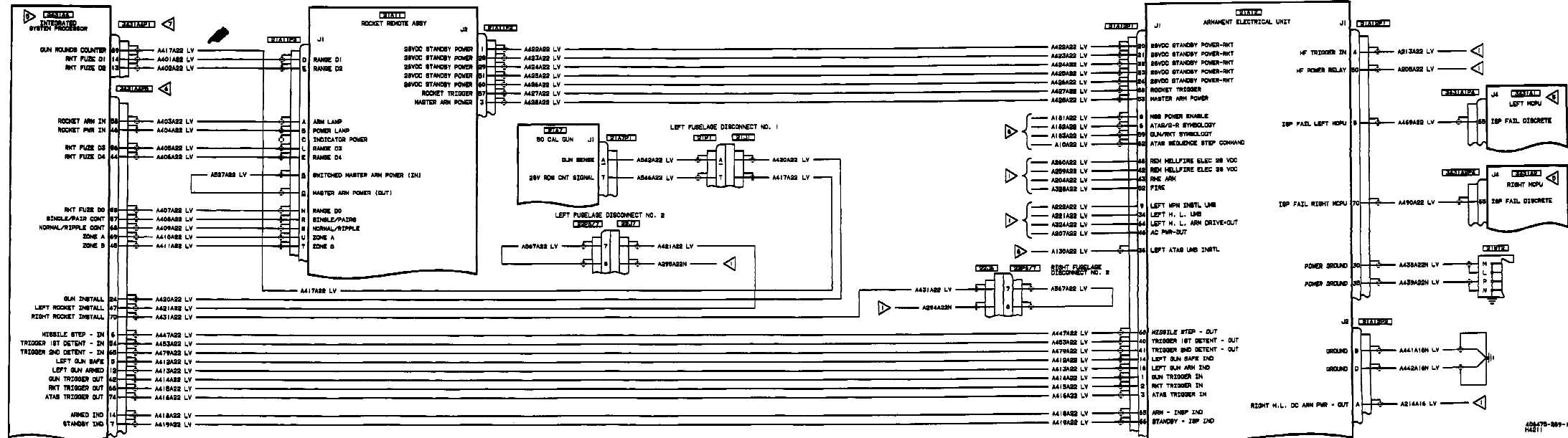

Change 3 FO-22. Guns and Rockets System Wiring Diagram (Sheet 1 of 4)

408470-209-1 44211

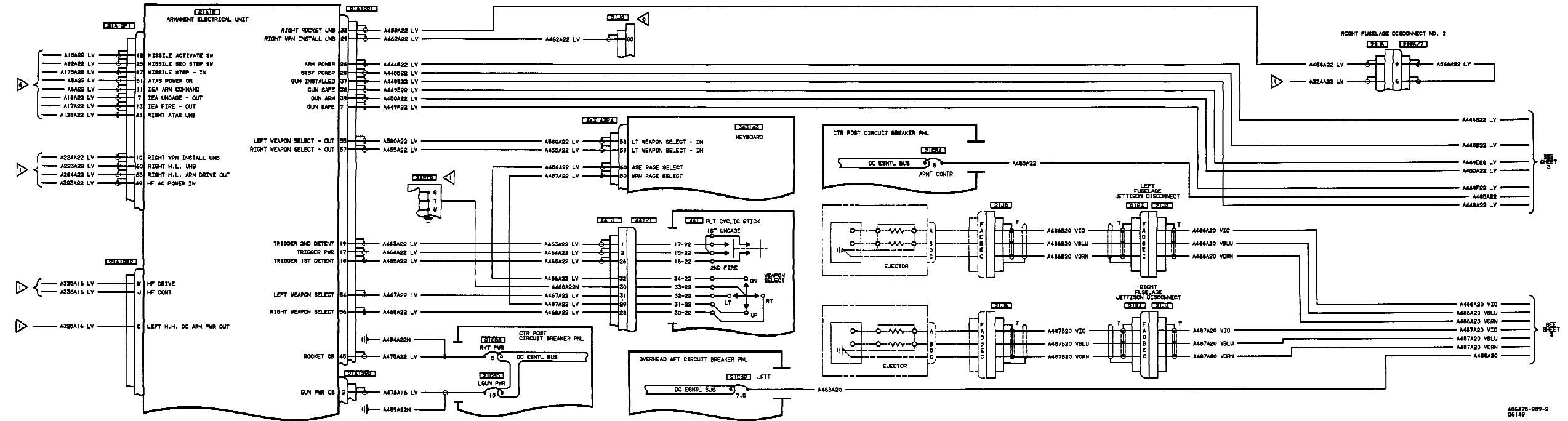

FO-22. Guns and Rockets System Wiring Diagram (Sheet 2 of 4)

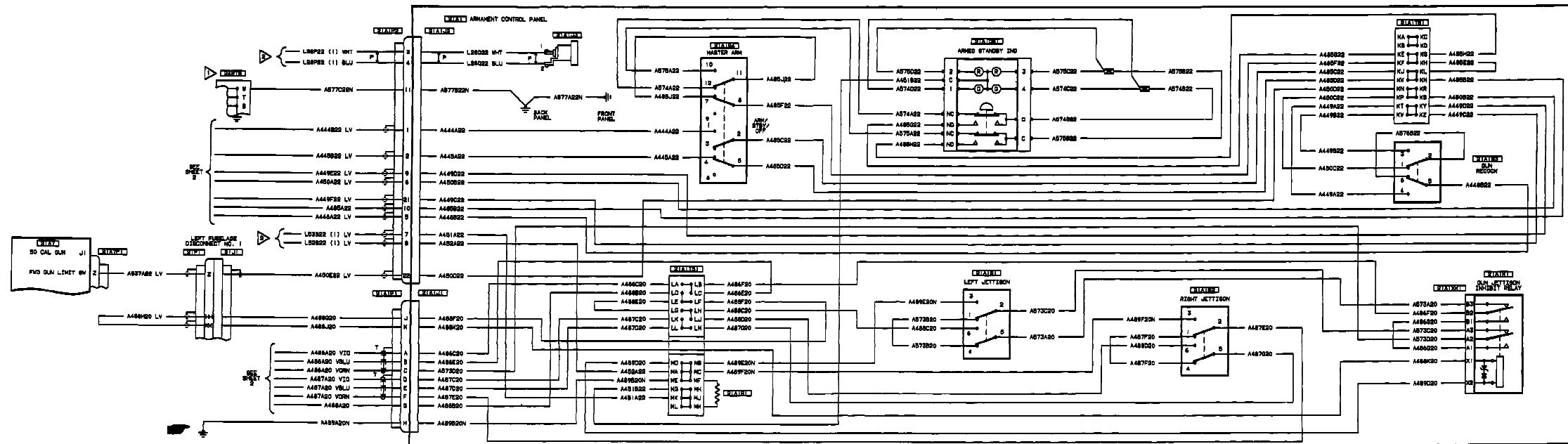

Change 3 FO-22 Guns and Rockets System Wiring Diagram (Sheet 3 of 4)

30875-289-3

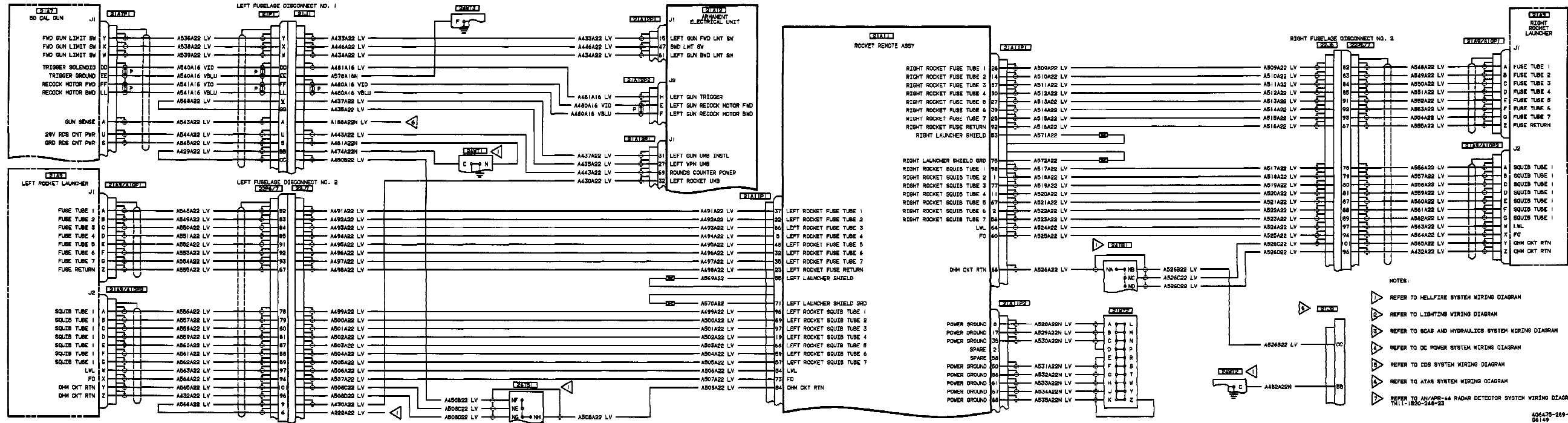

FO-22. Guns and Rockets System Wiring Diagram (Sheet 4 of 4)

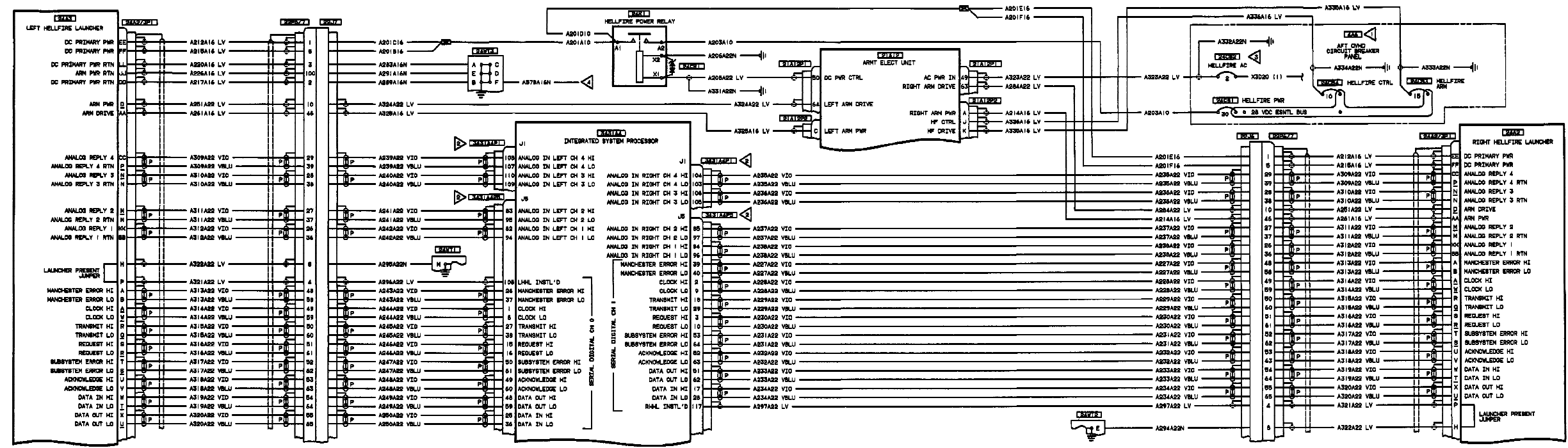

FO-23. HELLFIRE Missile System (HMS) Wiring Diagram (Sheet 1 of 3)

404475-291-1  
02151

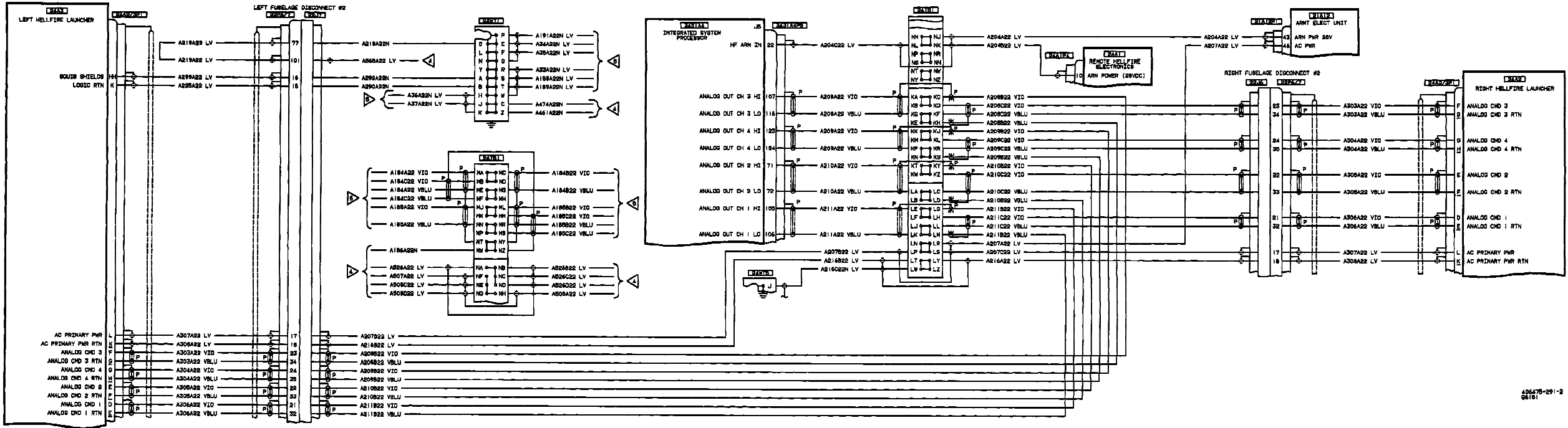





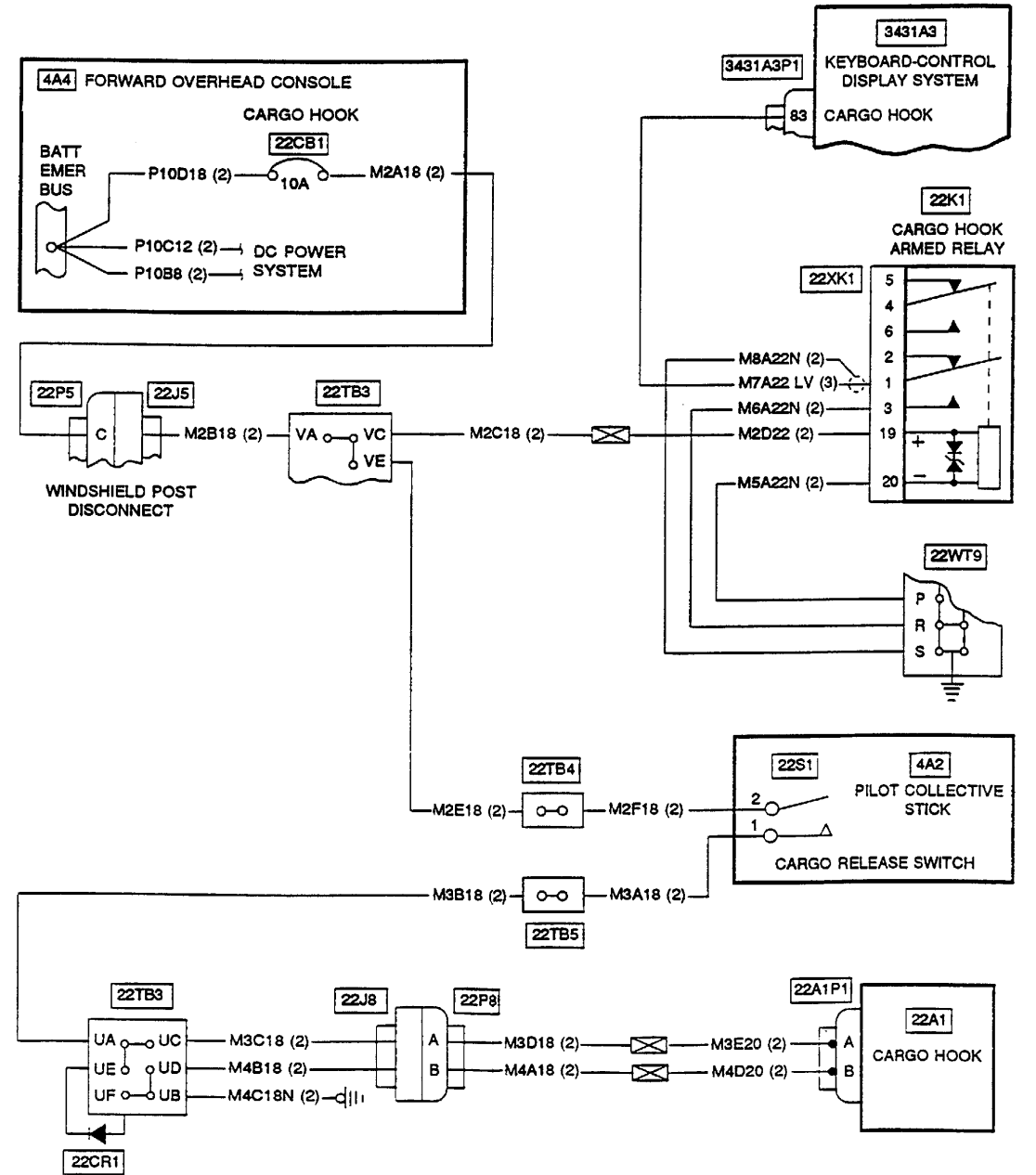

Figure FO-24. Cargo Hook Wiring Diagram  
Change 4 FP-199/(FP-200 blank)

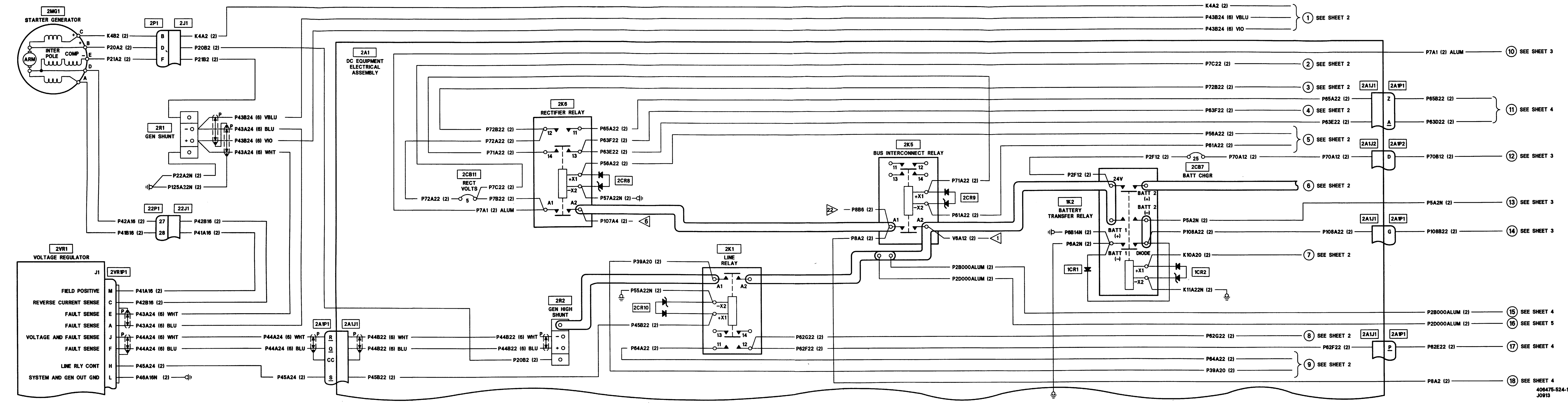

Figure FO-25. DC Power Systems Wiring Diagram OH-58D(R) (Sheet 1 of 6)



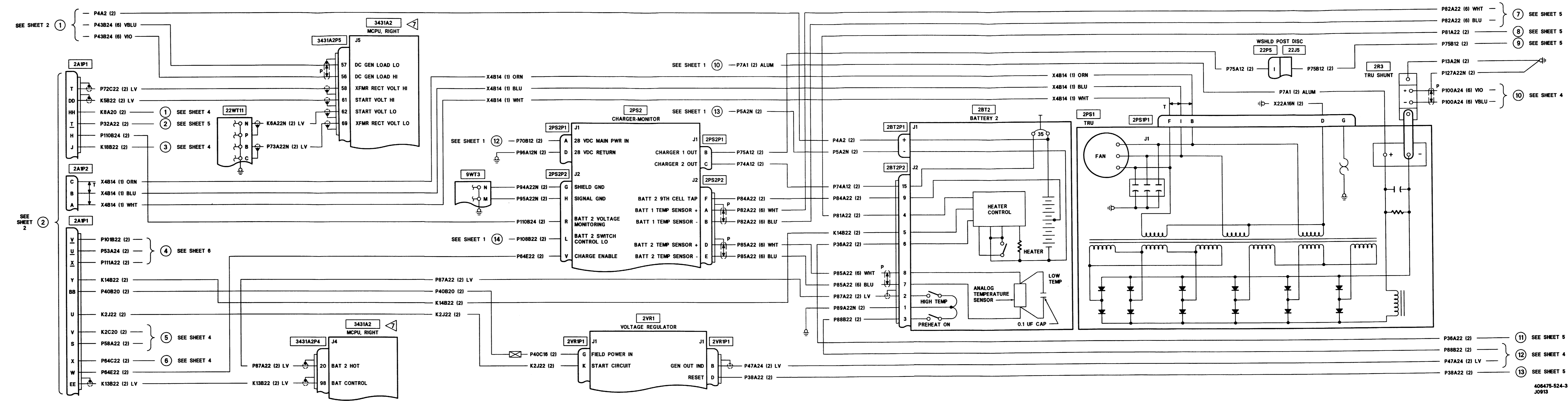

Figure FO-25. DC Power Systems Wiring Diagram OH-58D(R) (Sheet 3 of 6)

406475-524-3  
J0913

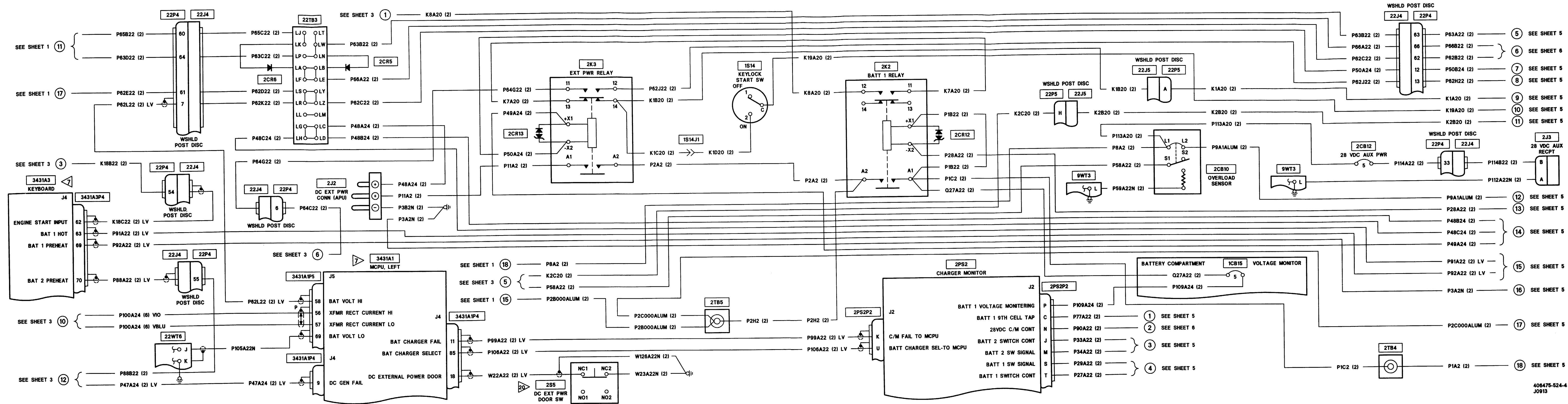
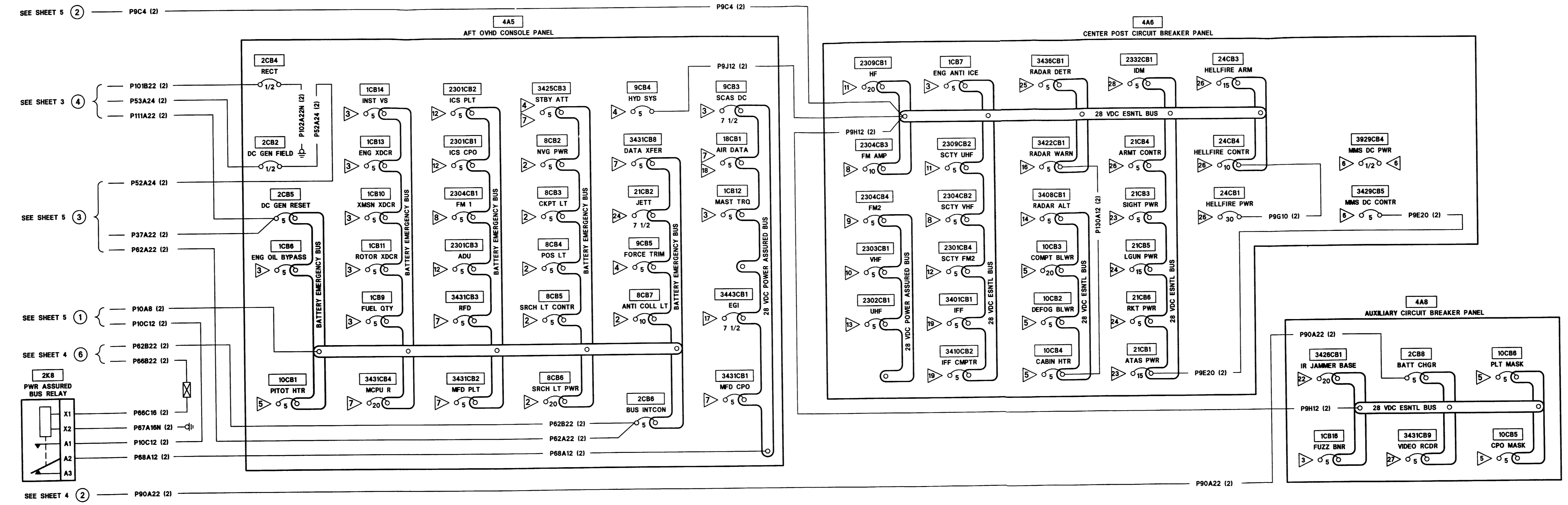

Figure FO-25. DC Power Systems Wiring Diagram OH-58D(R) (Sheet 4 of 6)

406475-524-4  
J0913





NOTES

- 1 REFER TO AC POWER SYSTEM WIRING DIAGRAM.
- 2 REFER TO LIGHTING SYSTEM WIRING DIAGRAM.
- 3 REFER TO POWERPLANT AND TRANSMISSION SYSTEM WIRING DIAGRAM.
- 4 REFER TO SCAS, HYDRAULIC, AND STANDBY ATTITUDE GYRO SYSTEM WIRING DIAGRAM.
- 5 REFER TO ENVIRONMENTAL SYSTEM WIRING DIAGRAM.
- 6 REFER TO MAST MOUNTED SIGHT (MMS) SYSTEM WIRING DIAGRAM.
- 7 REFER TO CONTROL DISPLAY SYSTEM (CDS) WIRING DIAGRAM.
- 8 REFER TO NO. 1 VHF-FM WIRING DIAGRAM TM 11-1520-248-23.
- 9 REFER TO NO. 2 VHF-FM WIRING DIAGRAM TM 11-1520-248-23.
- 10 REFER TO VHF-AM WIRING DIAGRAM TM 11-1520-248-23.
- 11 REFER TO HF WIRING DIAGRAM TM 11-1520-248-23.
- 12 REFER TO ICS WIRING DIAGRAM TM 11-1520-248-23.
- 13 REFER TO UHF WIRING DIAGRAM TM 11-1520-248-23.
- 14 REFER TO RADAR ALTIMETER WIRING DIAGRAM TM 11-1520-248-23.
- 15 REFER TO CARGO HOOK WIRING DIAGRAM.
- 16 REFER TO RADAR WARNING WIRING DIAGRAM TM 11-1520-248-23.
- 17 REFER TO EGI WIRING DIAGRAM TM 11-1520-248-23.
- 18 REFER TO AIR DATA SYSTEM (ADS) WIRING DIAGRAM.
- 19 REFER TO IFF WIRING DIAGRAM TM 11-1520-248-23.
- 20 SEE VIEW A FOR IDENTIFICATION OF SWITCH TERMINALS.
- 21 NUMBERED CIRCLE ON RIGHT SIDE OF SHEET SIGNIFIES \*SEE SHEET \* AND FIND SAME NUMBER ON LEFT SIDE OF SHEET WITH MATCHING WIRE NUMBER(S).
- 22 REFER TO AN/ALQ-144 WIRING DIAGRAM TM 11-1520-248-23.
- 23 REFER TO AIR-TO-AIR STINGER (ATAS) SYSTEM WIRING DIAGRAM.
- 24 REFER TO GUNS AND ROCKETS SYSTEM WIRING DIAGRAM.
- 25 REFER TO AN/APR-44 WIRING DIAGRAM TM 11-1520-248-23.
- 26 REFER TO HELLFIRE MISSILE SYSTEM (HMS) WIRING DIAGRAM.
- 27 REFER TO VIDEO TAPE RECORDER WIRING DIAGRAM TM 11-1520-248-23.
- 28 REFER TO IDM WIRING DIAGRAM TM 11-1520-248-23.

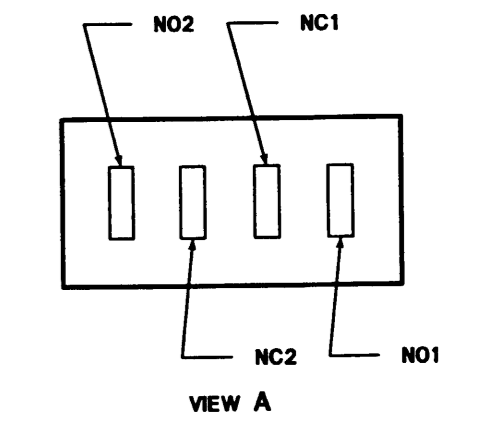

VIEW LOOKING AT REAR OF SWITCH [25] WITH KEYWAY UP

Figure FO-25. DC Power Systems Wiring Diagram OH-58D(R) (Sheet 6 of 6)

406475-524-6 J0913



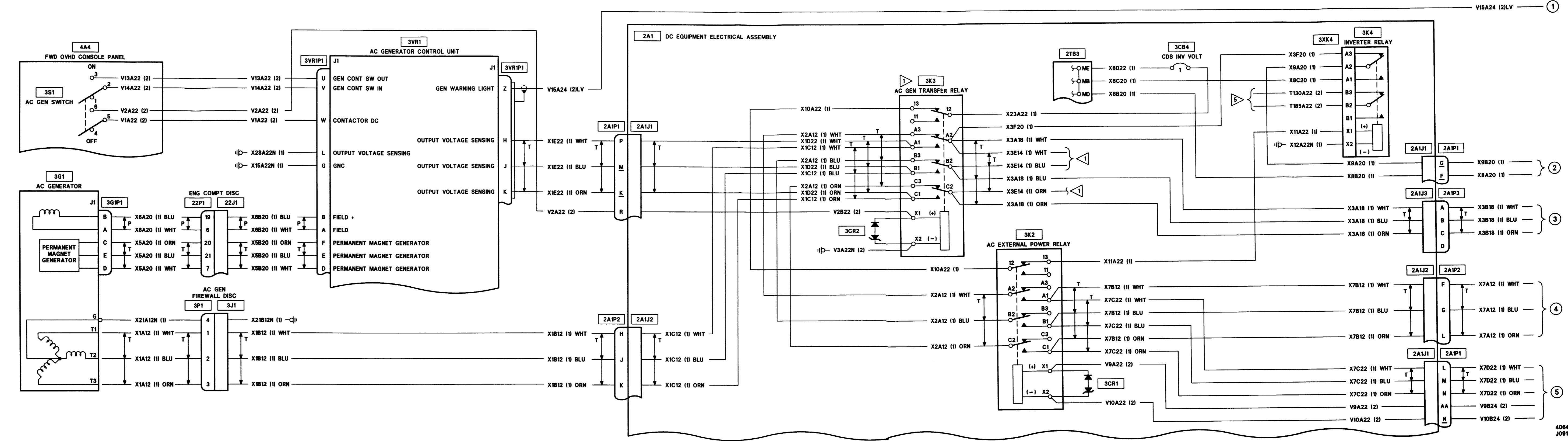
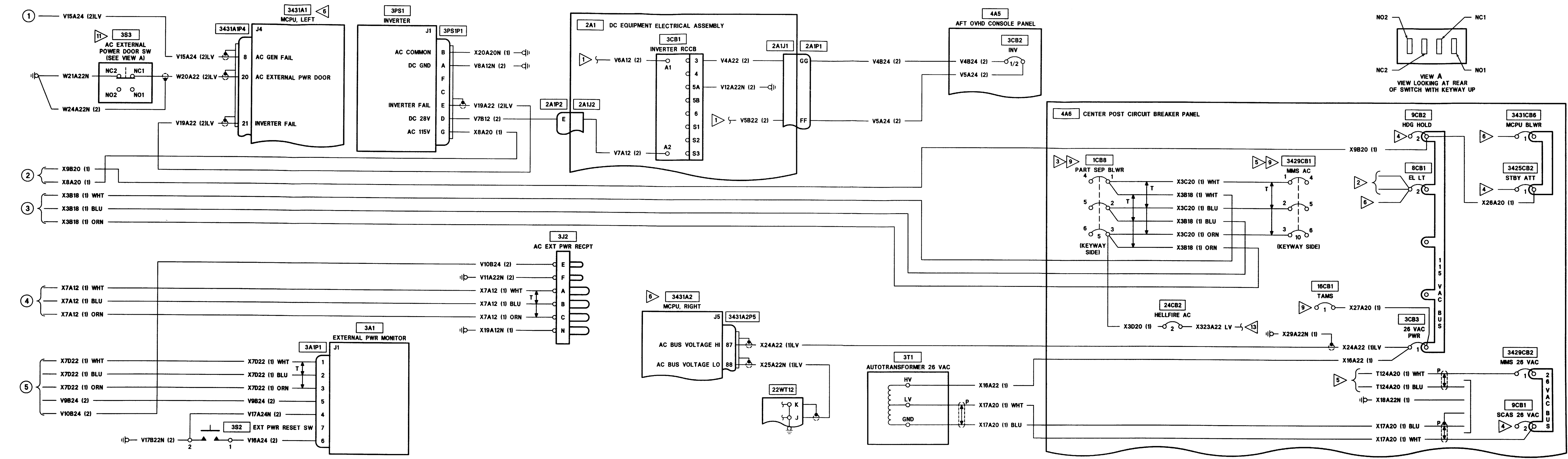

Figure FO-26. AC Power Systems Wiring Diagram OH-58D(R) (Sheet 1 of 2)

406475-525-1  
J0913



- NOTES
- 1 REFER TO DC POWER SYSTEM WIRING DIAGRAM.
  - 2 REFER TO LIGHTING SYSTEM WIRING DIAGRAM.
  - 3 REFER TO POWERPLANT AND TRANSMISSION SYSTEM WIRING DIAGRAM.
  - 4 REFER TO SCAS, HYDRAULIC, AND STANDBY ATTITUDE GYRO SYSTEM WIRING DIAGRAM.
  - 5 REFER TO MAST MOUNTED SIGHT (MMS) SYSTEM WIRING DIAGRAM.
  - 6 REFER TO CONTROL DISPLAY SYSTEM (CDS) WIRING DIAGRAM.
  - 7 REFER TO TAMS SYSTEM WIRING DIAGRAM.
  - 8 REFER TO HELLFIRE MISSILE SYSTEM (HMS) WIRING DIAGRAM.
  - 9 VIEW LOOKING AT REAR OF CIRCUIT BREAKER WITH KEYWAY UP. NUMBER WILL READ FROM LEFT TO RIGHT WITH 1, 2, AND 3 ON THE TOP OR KEYWAY SIDE.
  - 10 SWITCH SHOWN WITH DOOR OPEN SEE VIEW A FOR IDENTIFICATION OF SWITCH TERMINALS.
  - 11 NUMBERED CIRCLE ON RIGHT SIDE SIGNIFIES "GO TO NEXT SHEET" AND FIND SAME NUMBER ON LEFT SIDE OF SHEET WITH MATCHING NUMBER (S).

Figure FO-26. AC Power Systems Wiring Diagram OH-58D(R) (Sheet 2 of 2)

406475-525-2  
J0913



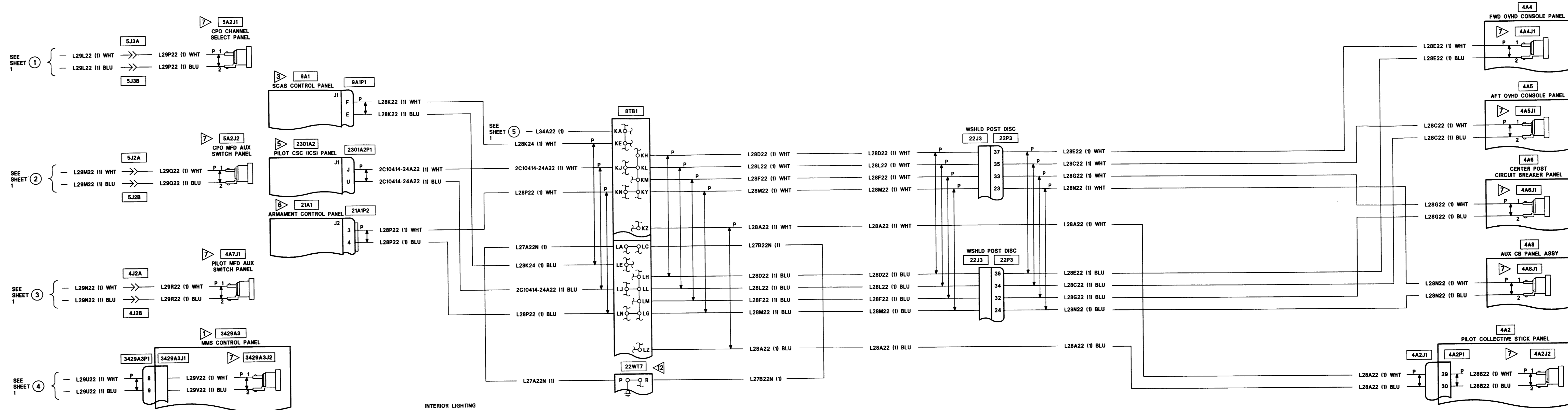

Figure FO-27. Lighting Systems Wiring Diagram OH-58D(R) (Sheet 2 of 4)

408475-528-2  
J0913

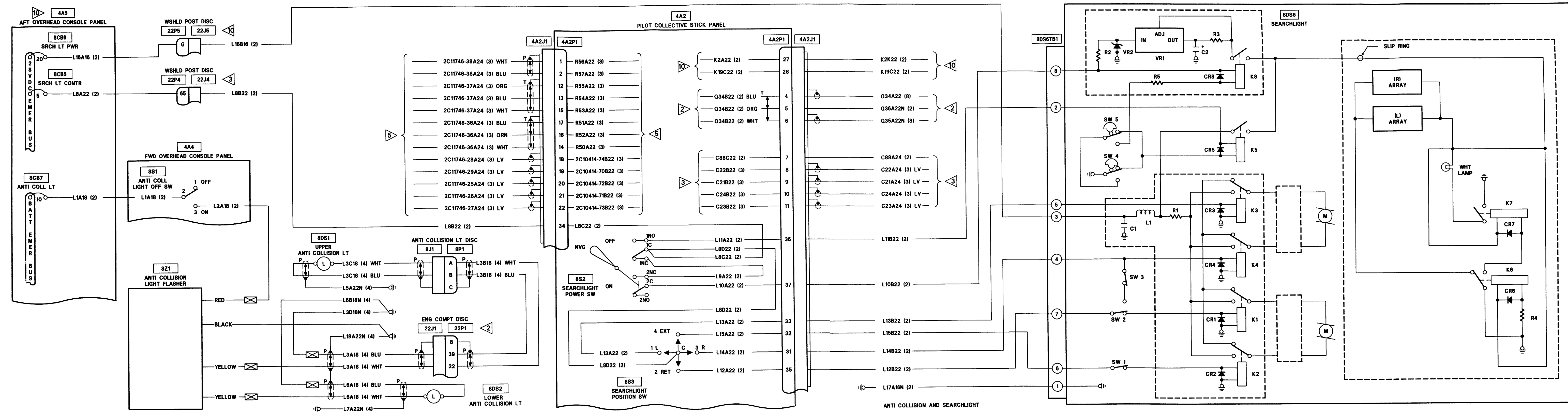
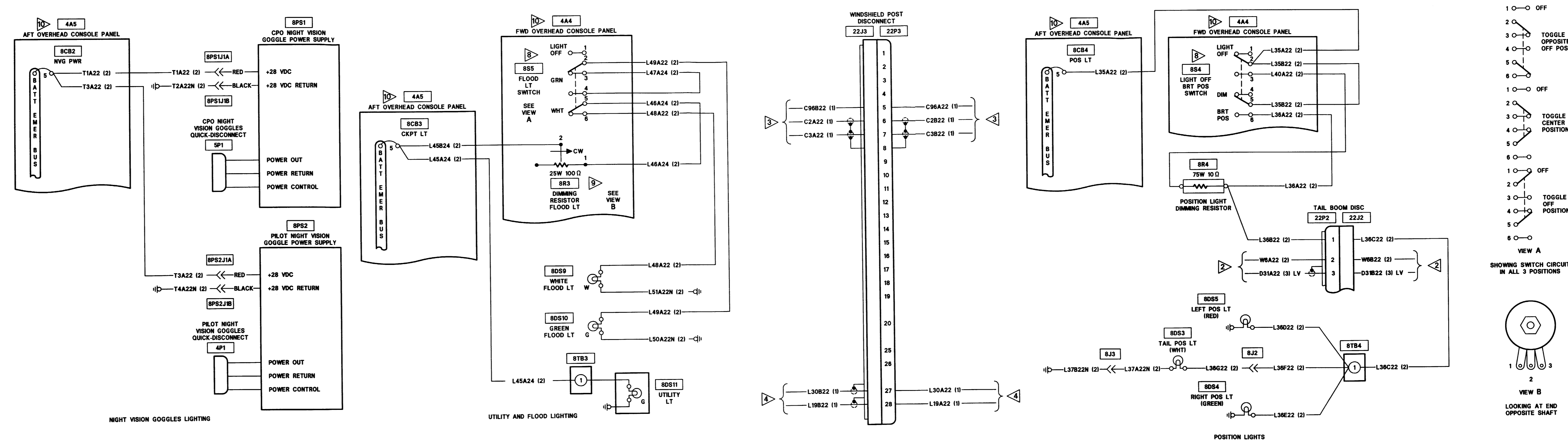

Figure FO-27. Lighting Systems Wiring Diagram OH-58D(R) (Sheet 3 of 4)

406475-526-3  
J0915



**NOTES:**

- REFER TO MAST MOUNTED SIGHT (MMS) SYSTEM WIRING DIAGRAM.
- REFER TO POWERPLANT AND TRANSMISSION SYSTEM WIRING DIAGRAM.
- REFER TO SCAS, HYDRAULICS AND STANDBY ATTITUDE GYRO SYSTEMS WIRING DIAGRAM.
- REFER TO CONTROL DISPLAY SYSTEM (CDS) WIRING DIAGRAM.
- REFER TO ICS WIRING DIAGRAM. TM 11-1520-248-23.
- REFER TO GUNS AND ROCKETS WIRING DIAGRAM.
- MS90335-1 CONNECTOR TERMINALS SHALL BE IDENTIFIED AS FOLLOWS:  
1. POSITIVE CONNECTION (CENTER TERMINAL).  
2. NEGATIVE CONNECTION (OUTER TERMINAL).
- SEE VIEW A FOR TOGGLE SWITCH POSITIONS.
- SEE VIEW B FOR TERMINAL CONNECTIONS.
- REFER TO DC POWER SYSTEM WIRING DIAGRAM.

**VIEW A**  
SHOWING SWITCH CIRCUIT IN ALL 3 POSITIONS

**VIEW B**  
LOOKING AT END OPPOSITE SHAFT

**Legend:**

- 1 - OFF
- 2 - TOGGLE OPPOSITE OFF POSITION
- 3 - TOGGLE CENTER POSITION
- 4 - TOGGLE OFF POSITION

Figure FO-27. Lighting Systems Wiring Diagram OH-58D(R) (Sheet 4 of 4)

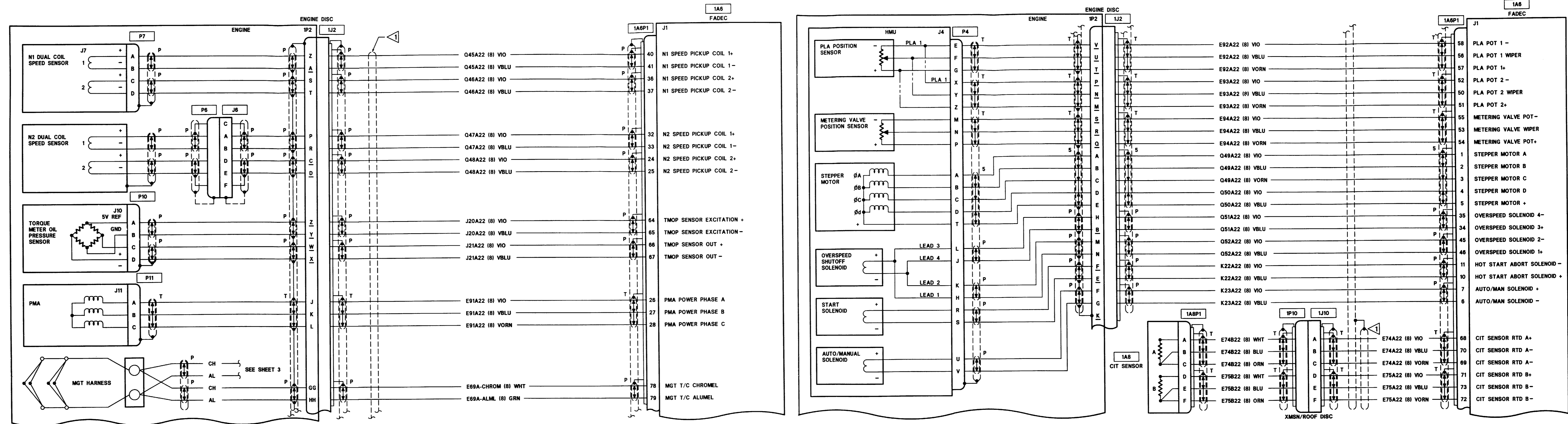

Figure FO-28. Power Plant and Transmission Systems Wiring Diagram OH-58D(R) (Sheet 1 of 9)

406475-527-1  
J0913

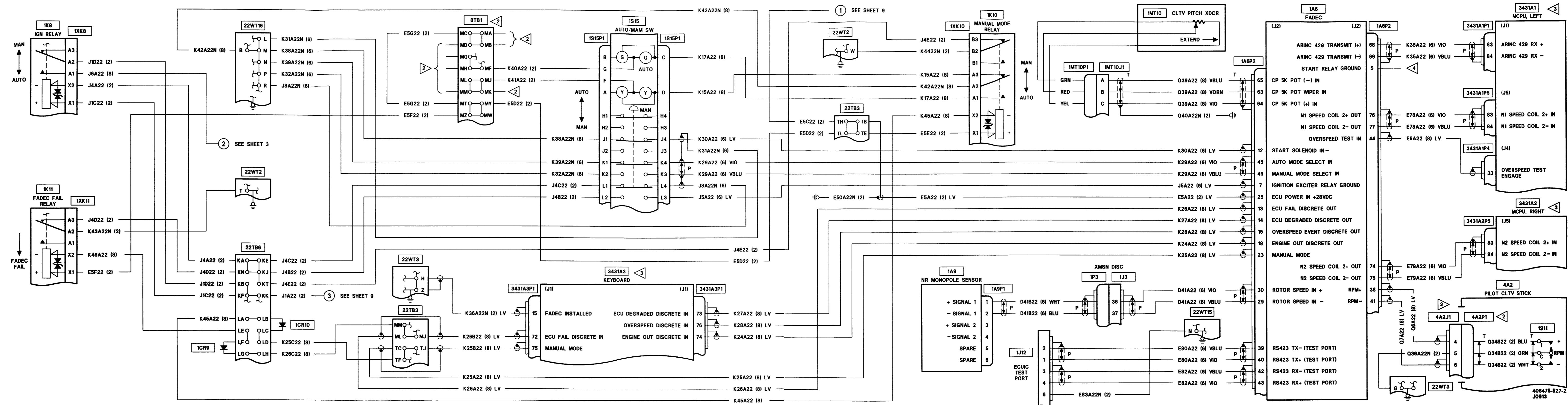

Figure FO-28. Power Plant and Transmission Systems Wiring Diagram OH-58D(R) (Sheet 2 of 9)



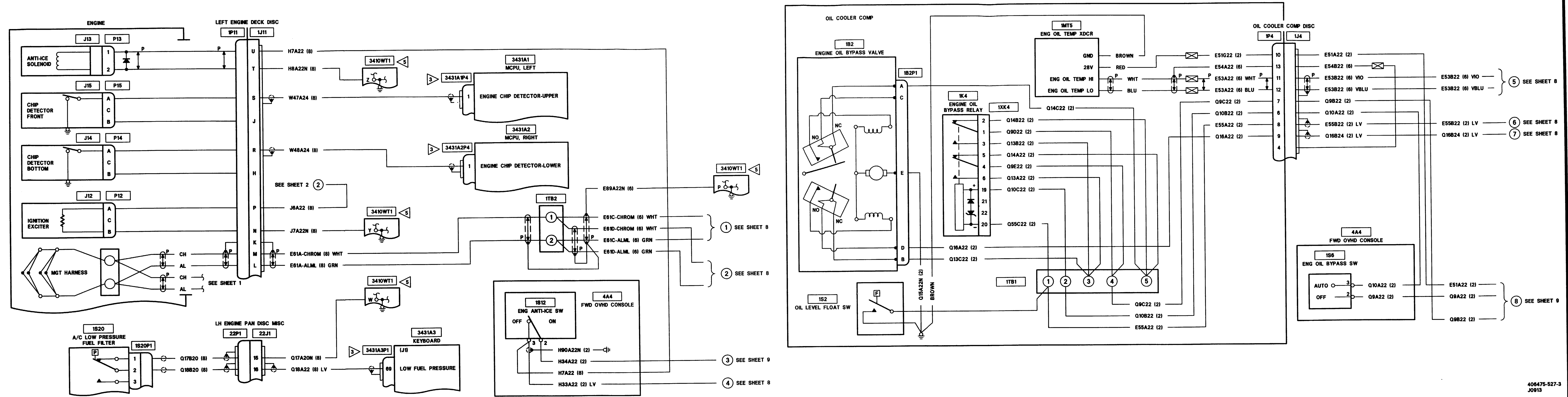

Figure FO-28. Power Plant and Transmission Systems Wiring Diagram OH-58D(R) (Sheet 3 of 9)

406475-527-3  
J0913

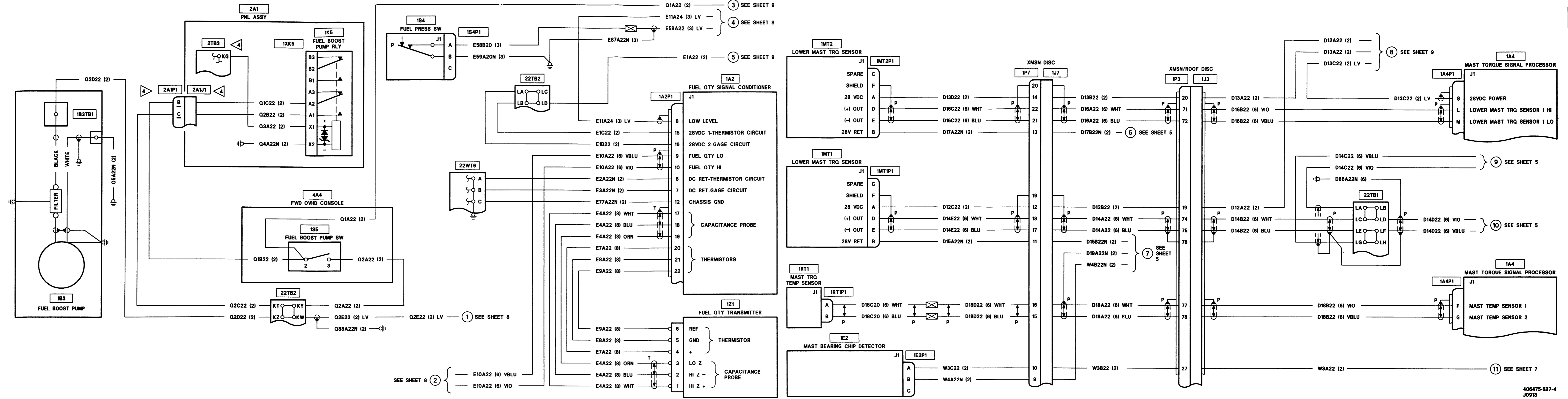

Figure FO-28. Power Plant and Transmission Systems Wiring Diagram OH-58D(R) (Sheet 4 of 9)

406475-527-4  
J0913

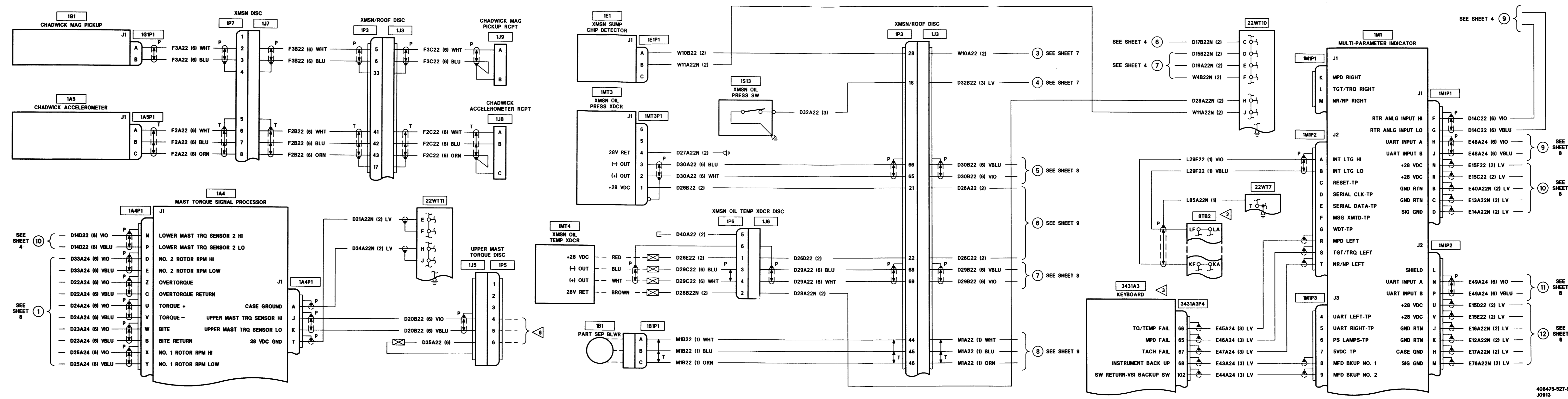

Figure FO-28. Power Plant and Transmission Systems Wiring Diagram OH-58D(R) (Sheet 5 of 9)

406475-527-5  
J0913

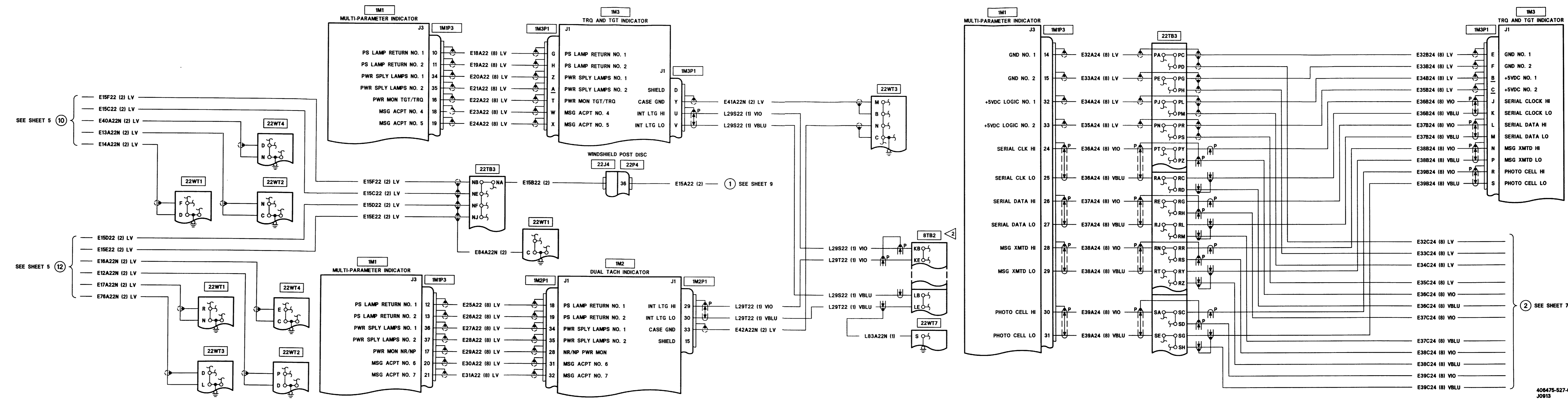

Figure FO-28. Power Plant and Transmission Systems Wiring Diagram OH-58D(R) (Sheet 6 of 9)

406475-527-6  
J0913

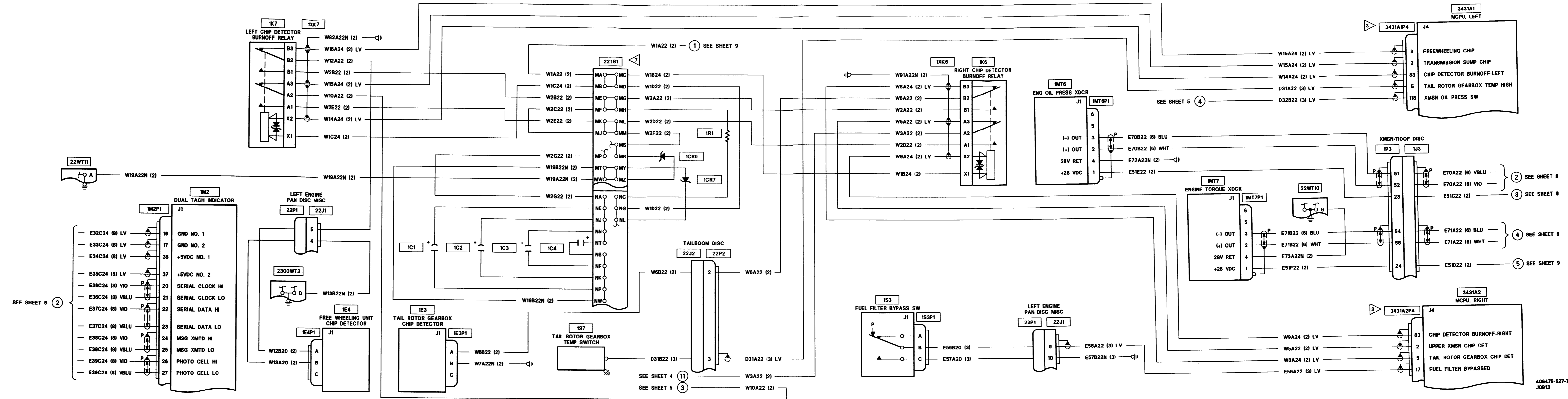

Figure FO-28. Power Plant and Transmission Systems Wiring Diagram OH-58D(R) (Sheet 7 of 9)

406475-527-7  
J0913

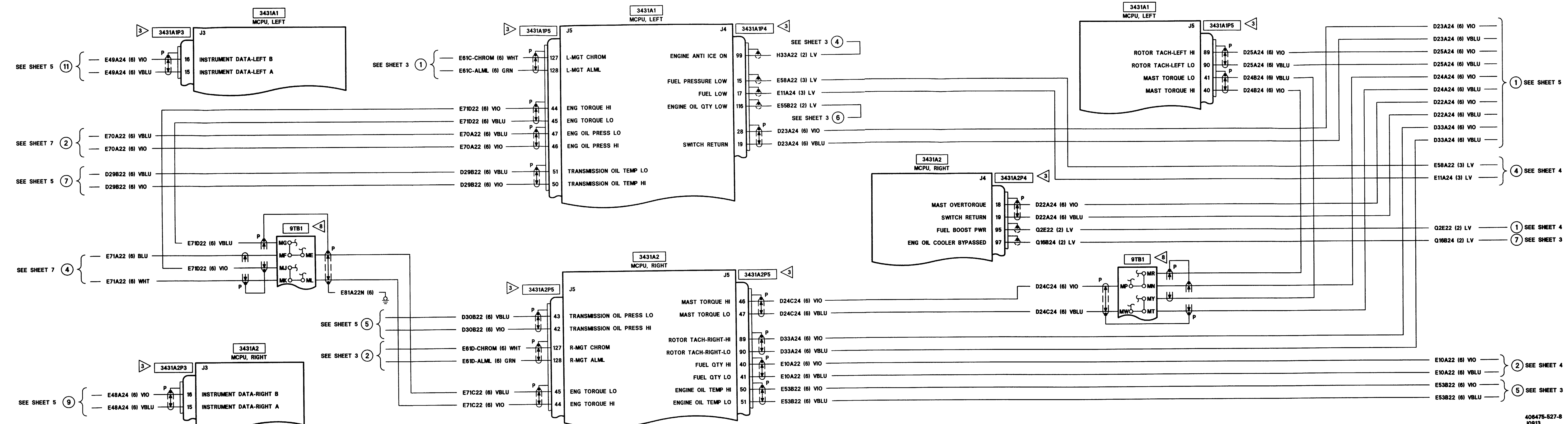

Figure FO-28. Power Plant and Transmission Systems Wiring Diagram OH-58D(R) (Sheet 8 of 9)

406475-527-8  
J0913

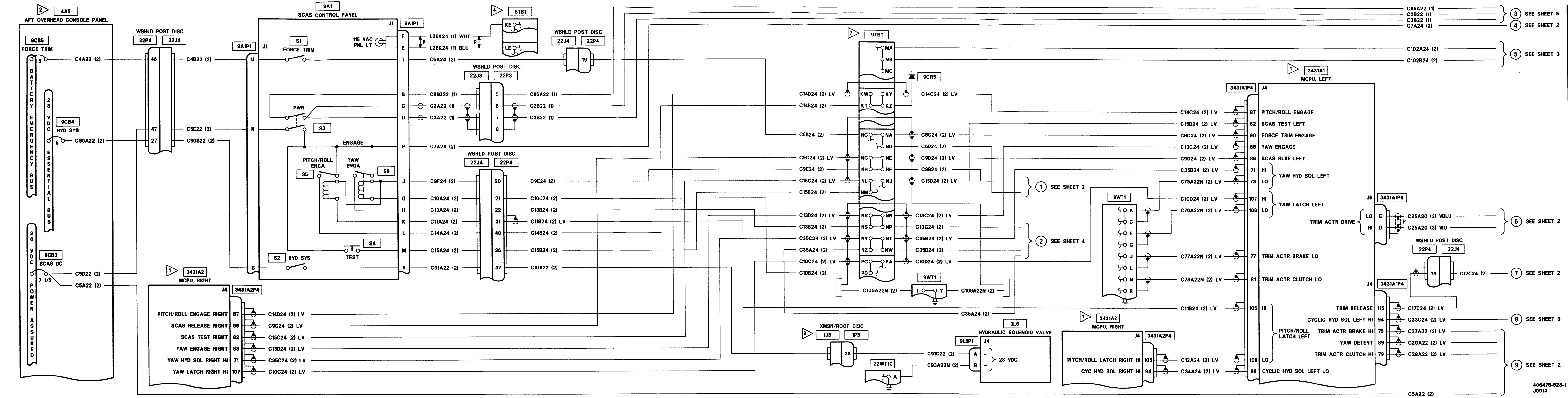
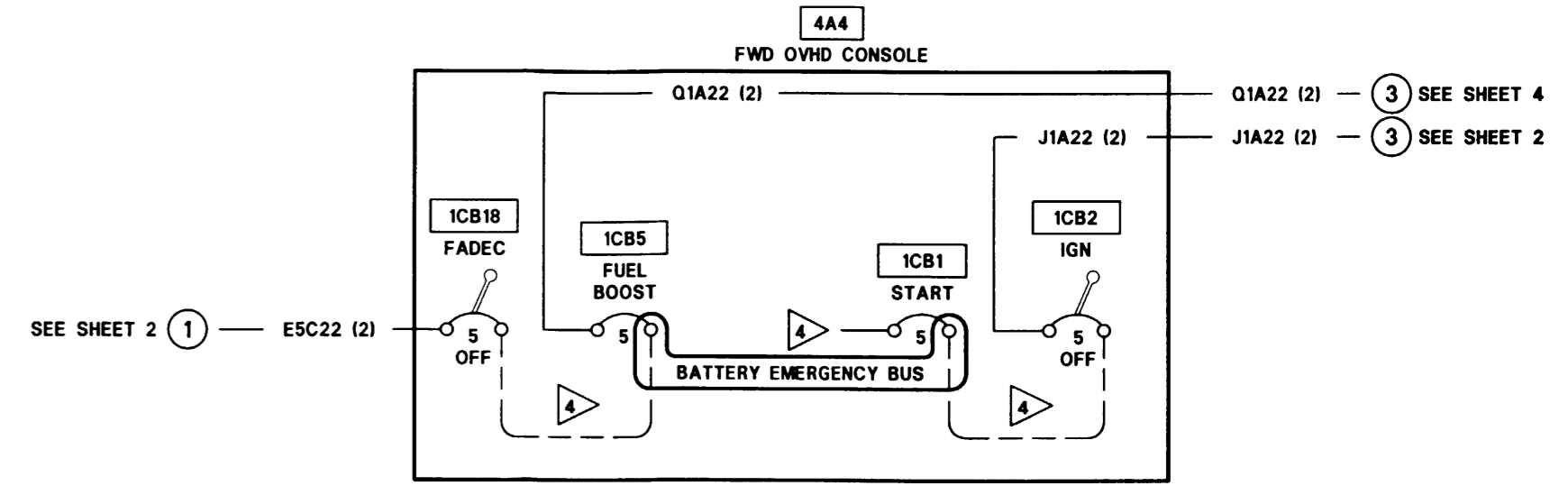
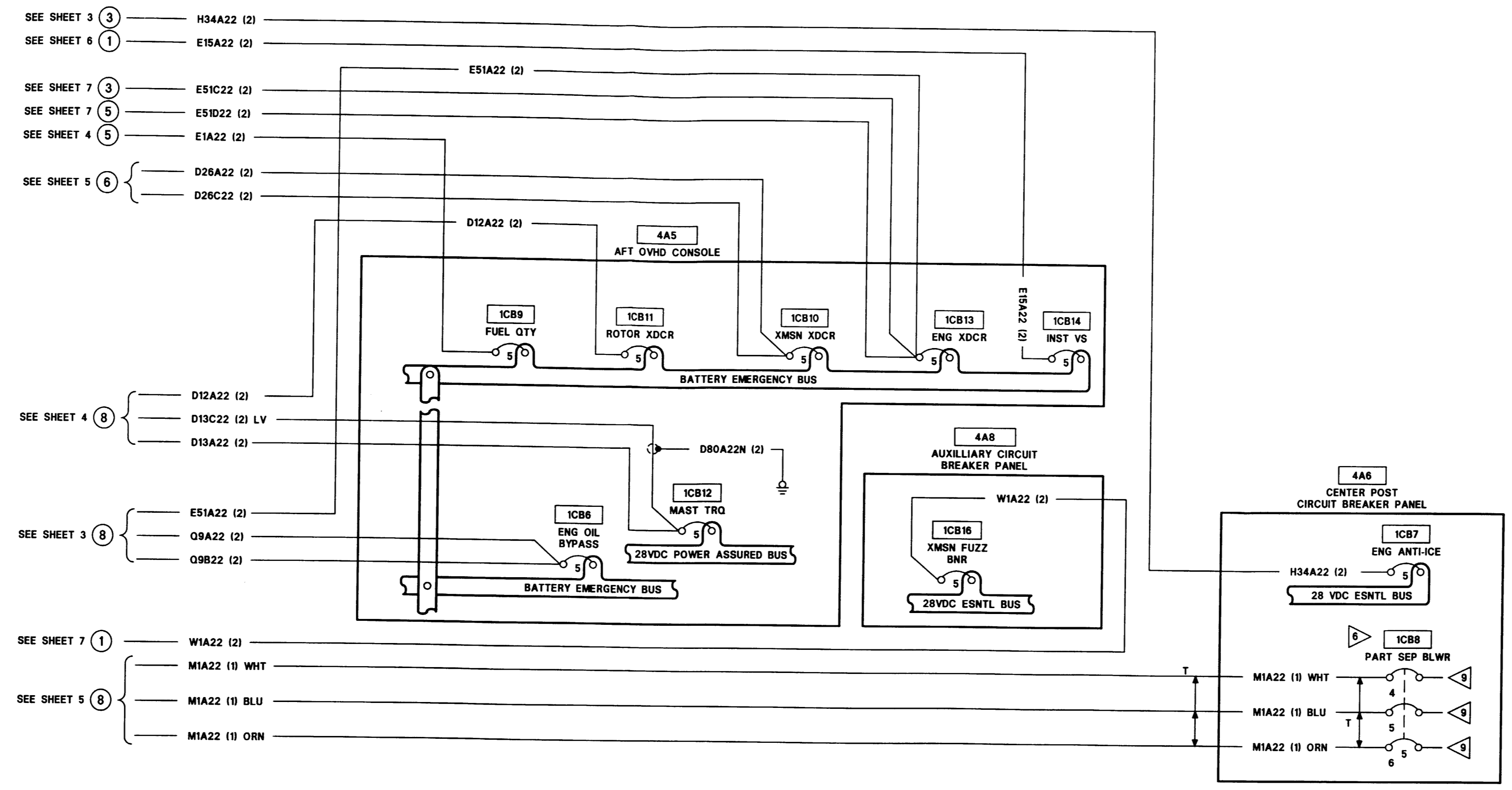

Figure FO-29. SCAS and Hydraulic Systems Wiring Diagram OH-58D(R) (Sheet 1 of 6)



- NOTES
- 1 EM/RFI SHIELDING OF HARNESS AND SHIELD TERMINATION OF GROSS SHIELD.
  - 2 REFER TO LIGHTING WIRING DIAGRAM.
  - 3 REFER TO CONTROL DISPLAY SYSTEM (CDS) WIRING DIAGRAM.
  - 4 REFER TO DC POWER SYSTEM WIRING DIAGRAM.
  - 5 REFER TO IFF WIRING DIAGRAM TM 11-1520-248-23.
  - 6 REFER TO MAST MOUNTED SIGHT (MMS) SYSTEM WIRING DIAGRAM.
  - 7 REFER TO UHF WIRING DIAGRAM TM 11-1520-248-23.
  - 8 REFER TO EGI WIRING DIAGRAM.
  - 9 REFER TO AC POWER SYSTEM WIRING DIAGRAM.

406475-527-9  
J0913

Figure FO-28. Power Plant and Transmission Systems Wiring Diagram OH-58D(R) (Sheet 9 of 9)





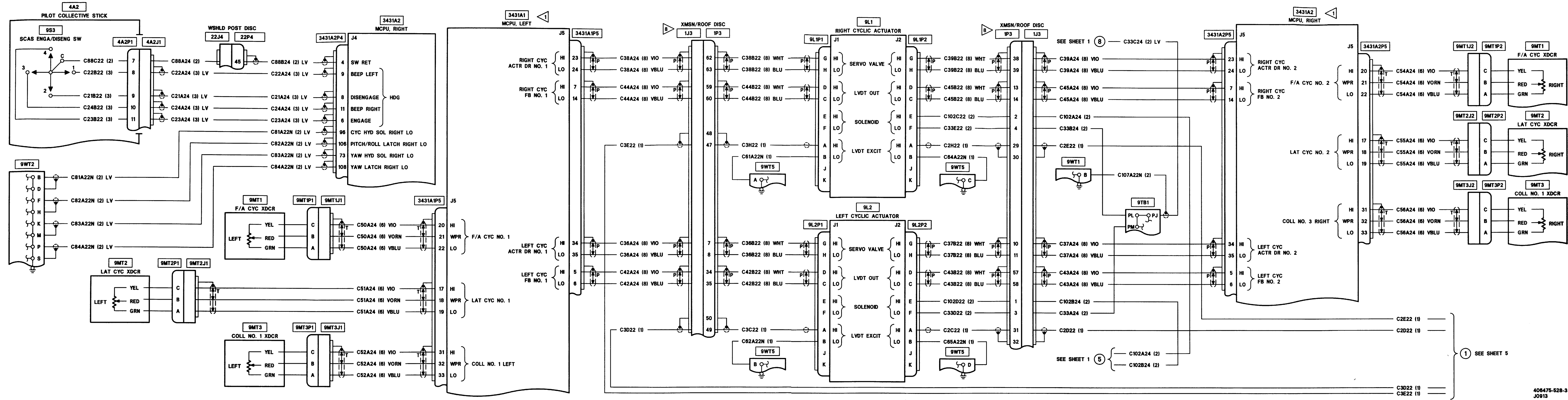

Figure FO-29. SCAS and Hydraulic Systems Wiring Diagram OH-58D(R) (Sheet 3 of 6)

406475-528-3  
J0913



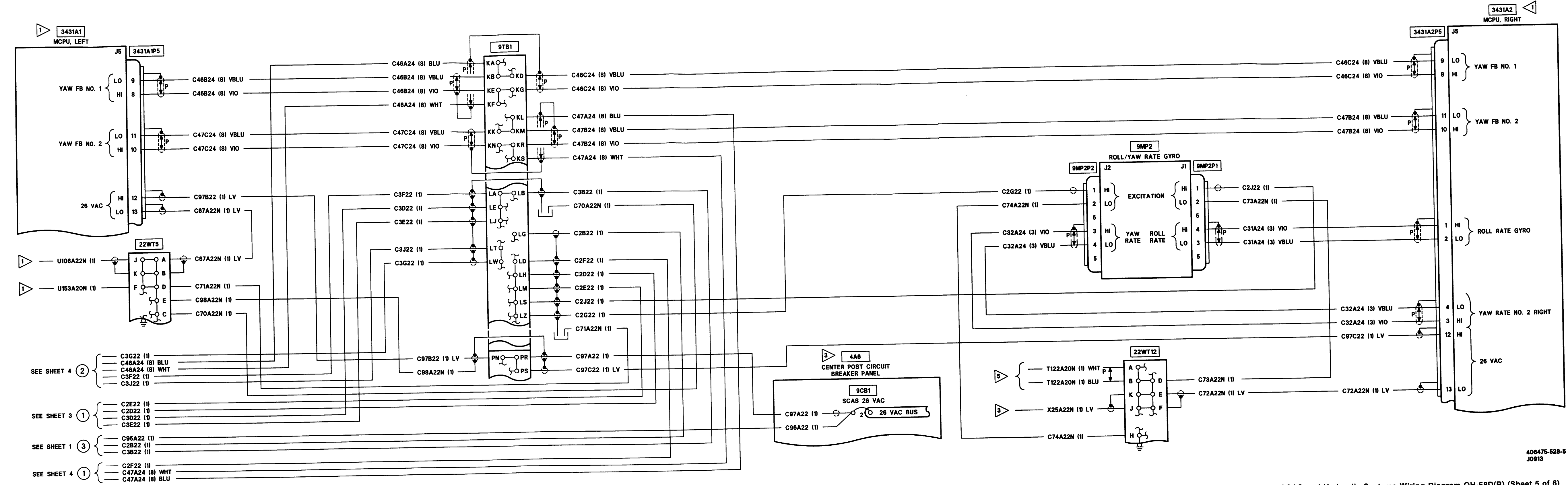
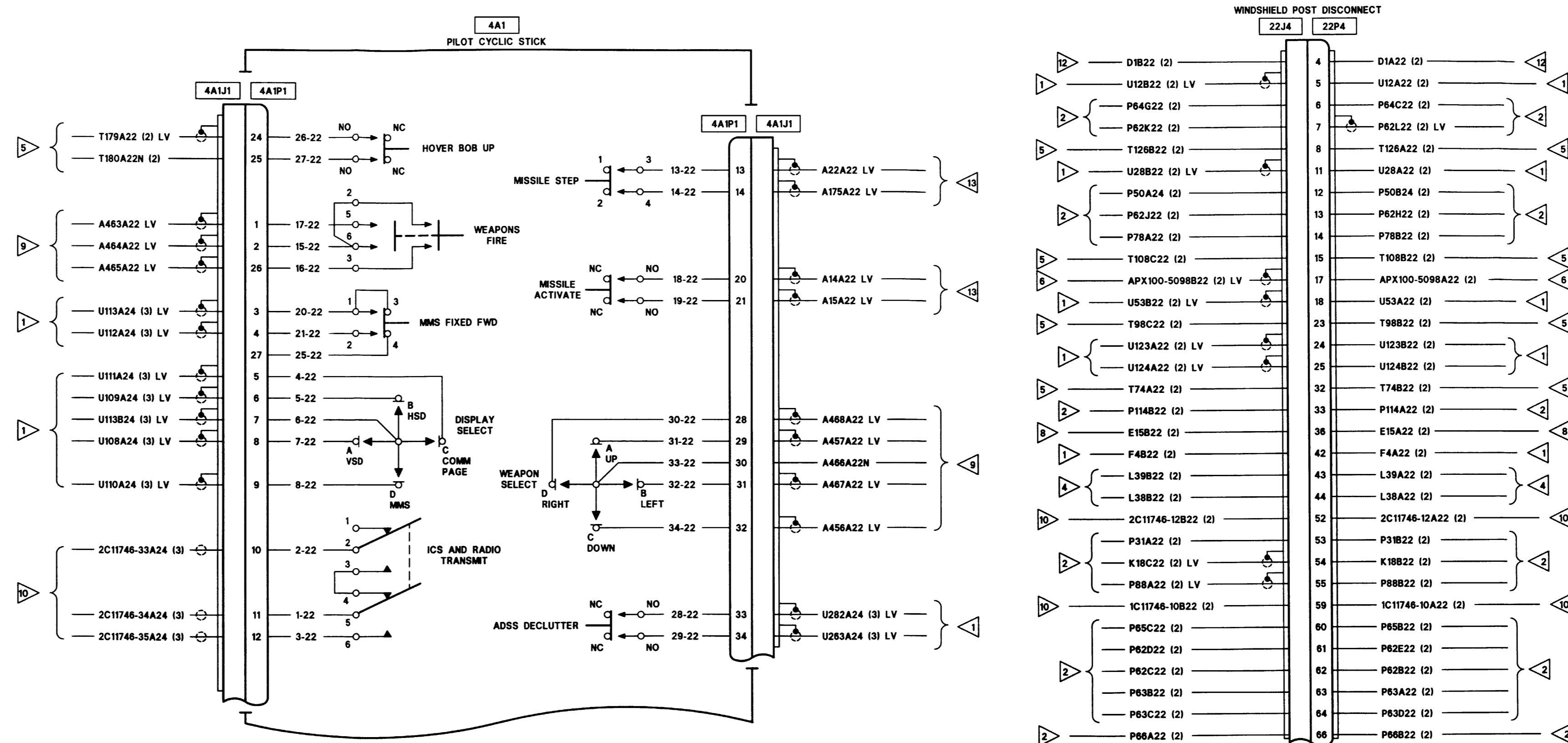

Figure FO-29. SCAS and Hydraulic Systems Wiring Diagram OH-58D(R) (Sheet 5 of 6)

406475-528-5 J0813



- NOTES**
- 1 REFER TO CONTROL DISPLAY SYSTEM (CDS) WIRING DIAGRAM.
  - 2 REFER TO DC POWER SYSTEM WIRING DIAGRAM.
  - 3 REFER TO AC POWER SYSTEM WIRING DIAGRAM.
  - 4 REFER TO LIGHTING SYSTEM WIRING DIAGRAM.
  - 5 REFER TO MAST MOUNTED SIGHT (MMS) SYSTEM WIRING DIAGRAM.
  - 6 REFER TO IFF WIRING DIAGRAM TM 11-1520-248-23.
  - 7 REFER TO EGI SYSTEM WIRING DIAGRAM TM 11-1520-248-23.
  - 8 REFER TO POWER PLANT AND TRANSMISSION WIRING DIAGRAM.
  - 9 REFER TO GUNS AND ROCKETS SYSTEM WIRING DIAGRAM.
  - 10 REFER TO ICS WIRING DIAGRAM TM 11-1520-248-23.
  - 11. NUMBERED CIRCLE ON RIGHT SIDE OF SHEET SIGNIFIES "GO TO NEXT SHEET" AND FIND SAME NUMBER ON LEFT SIDE OF SHEET WITH MATCHING WIRE NUMBER(S).
  - 12 REFER TO ADS WIRING DIAGRAM.
  - 13 REFER TO ATAS WIRING DIAGRAM.

Figure FO-29. SCAS and Hydraulic Systems Wiring Diagram OH-58D(R) (Sheet 6 of 6)

406475-528-6  
J0913

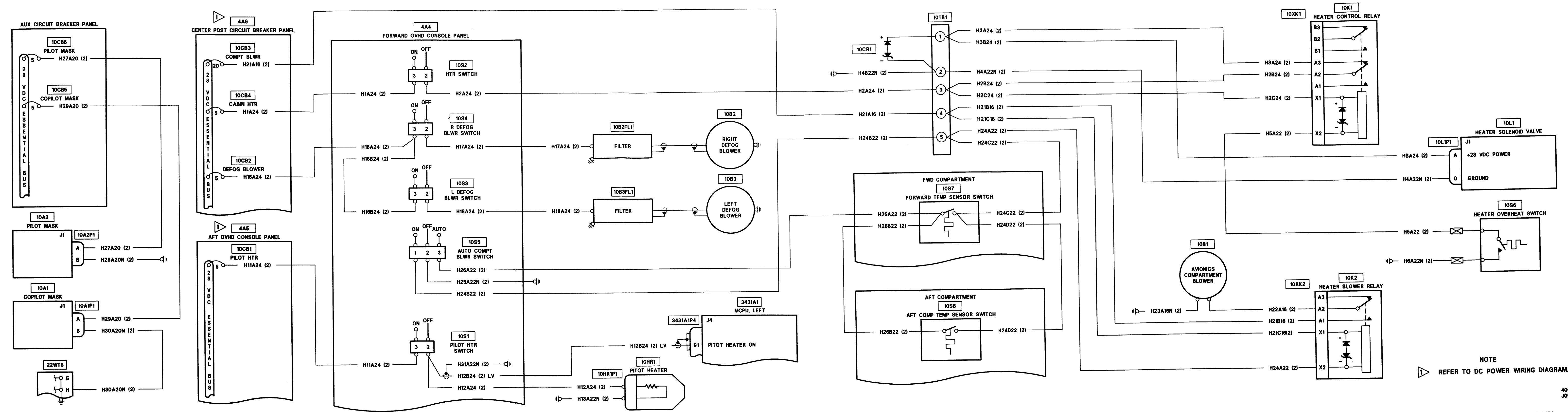

NOTE  
REFER TO DC POWER WIRING DIAGRAM.

Figure FO-30. Environmental Electrical Systems Wiring Diagram OH-58D(R)

406475-529  
J0913

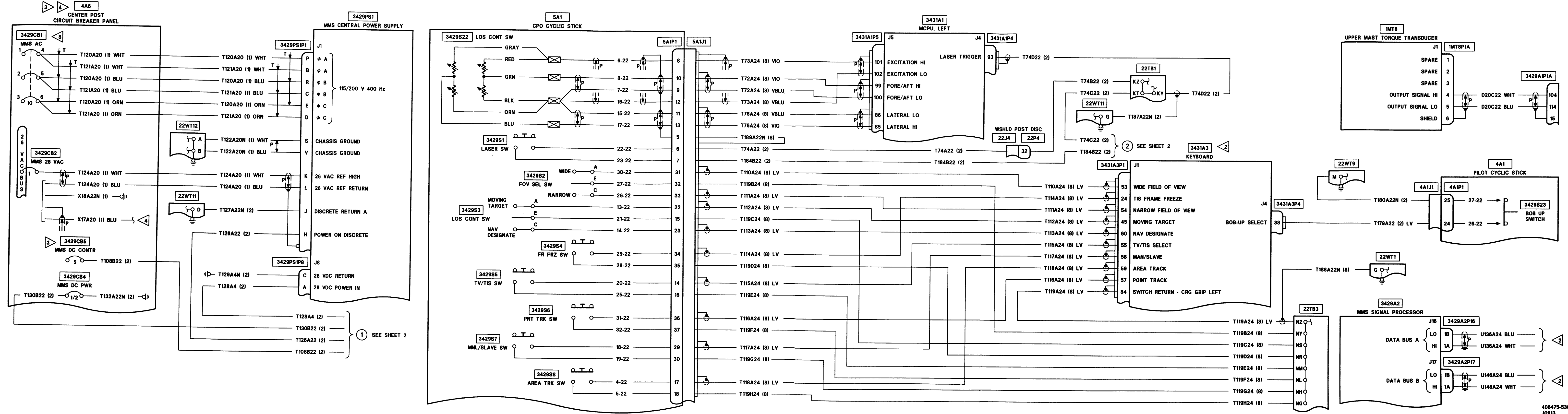

Figure FO-31. Mast Mounted Sight (MMS) System Wiring Diagram OH-58D(R) (Sheet 1 of 5)





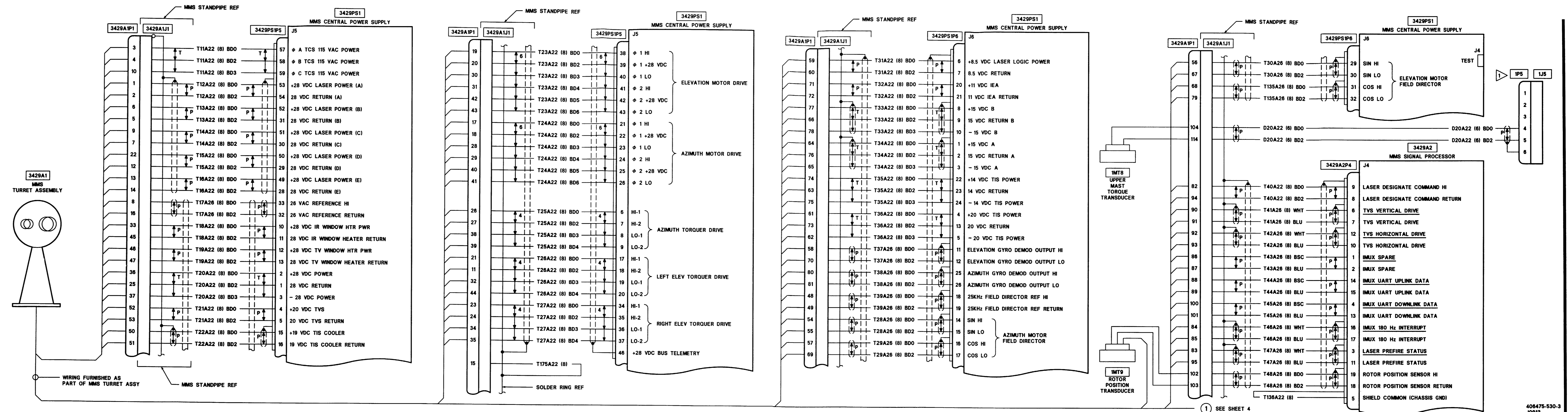
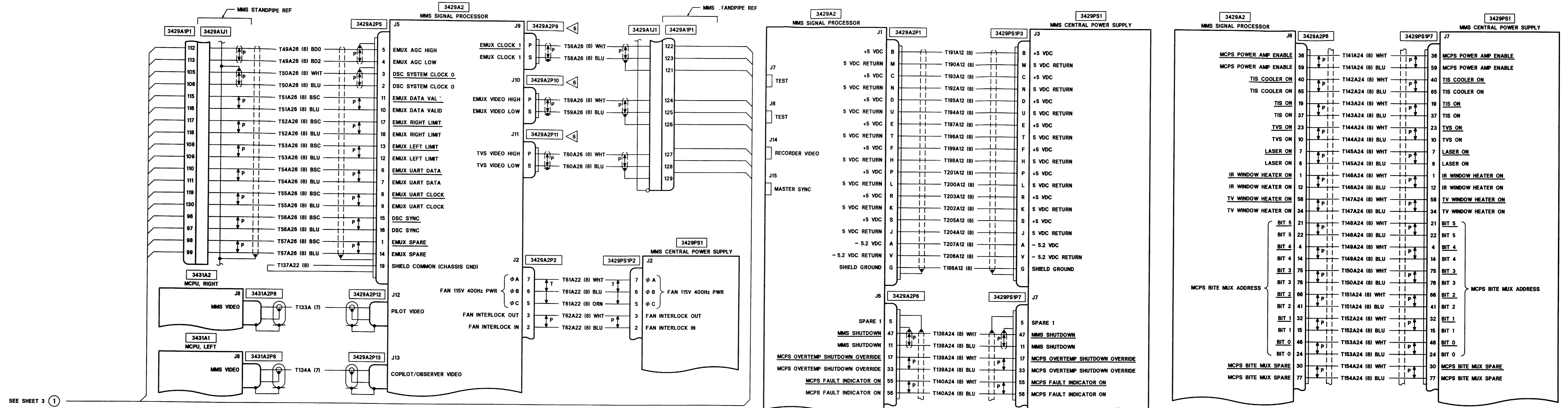

Figure FO-31. Mast Mounted Sight (MMS) System Wiring Diagram OH-58D(R) (Sheet 3 of 5)



SEE SHEET 3 ①

406475-530-4  
J0913

Figure FO-31. Mast Mounted Sight (MMS) System Wiring Diagram OH-58D(R) (Sheet 4 of 5)

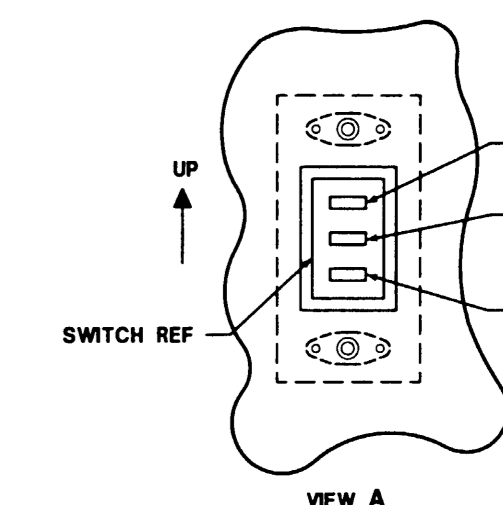
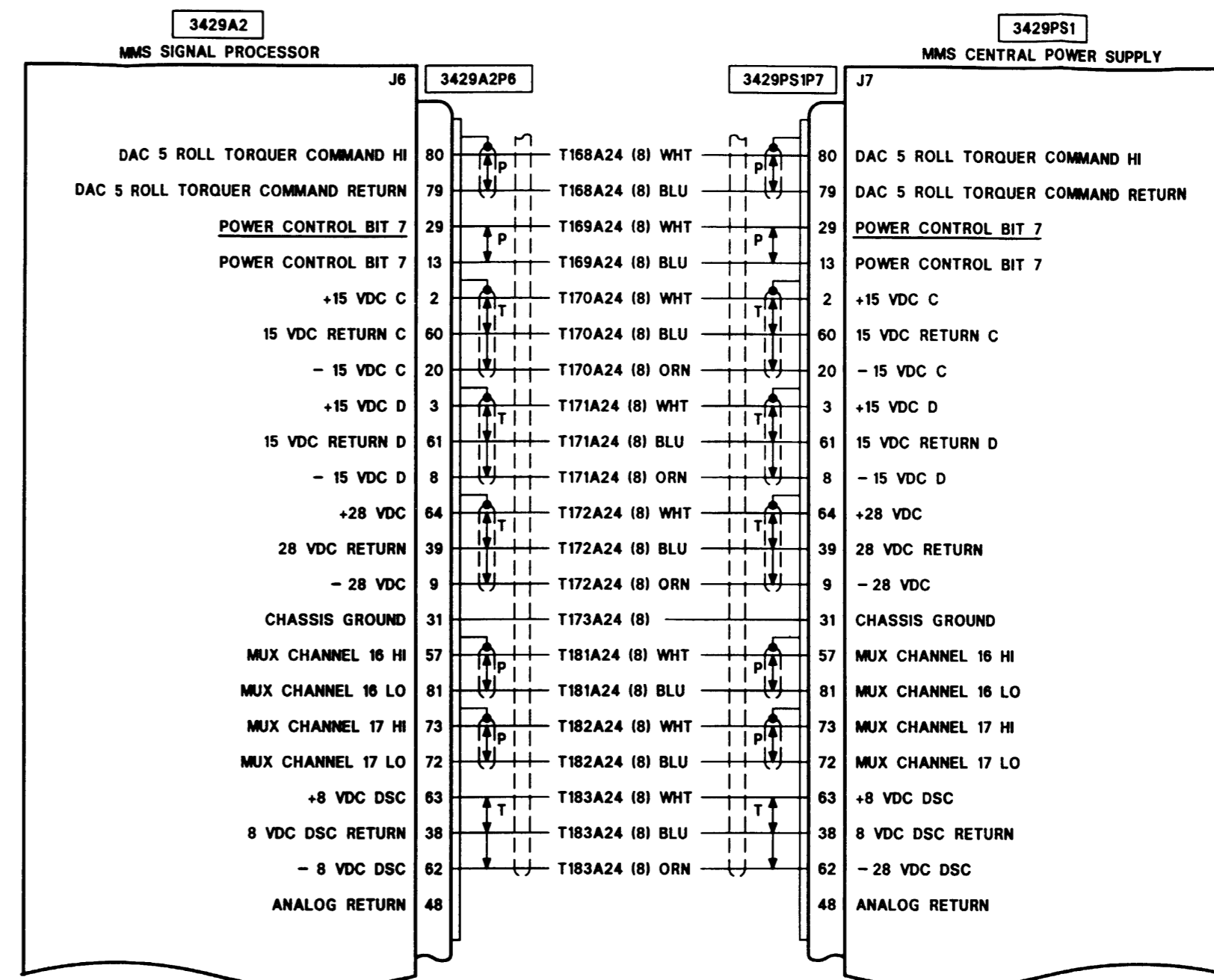
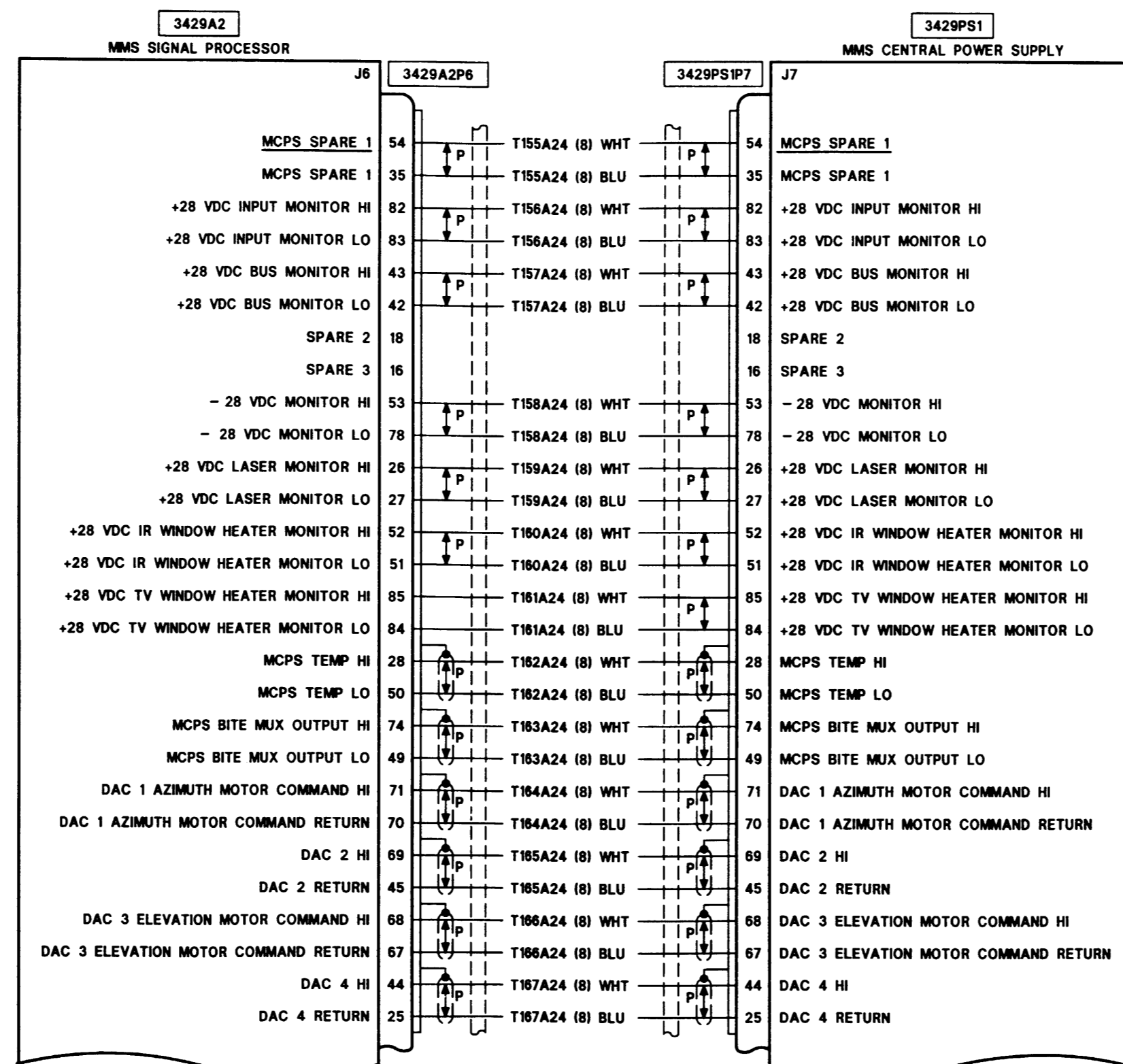

VIEW A  
VIEW LOOKING AT REAR OF SWITCH AS INSTALLED IN PANEL TO SHOW SWITCH TERMINAL (1, 2, OR 3) IDENTIFICATION.

- NOTES
- 1 REFER TO POWERPLANT AND TRANSMISSION SYSTEM WIRING DIAGRAM.
  - 2 REFER TO CONTROL DISPLAY SYSTEM (CDS) WIRING DIAGRAM.
  - 3 REFER TO DC POWER SYSTEM WIRING DIAGRAM.
  - 4 REFER TO AC POWER SYSTEM WIRING DIAGRAM.
  - 5 REFER TO LIGHTING SYSTEM WIRING DIAGRAM.
  - 6 FURNISHED CONNECTOR CONTACT IDENTIFICATION FOR TERMINATING A 2-CONDUCTOR SHIELDED, JACKETED CABLE SHALL BE AS FOLLOWS:  
P = PIN CONTACT  
S = SOCKET CONTACT
  - 7 SEE VIEW A FOR SWITCH TERMINAL IDENTIFICATION.
  - 8 VIEW LOOKING AT REAR OF CIRCUIT BREAKER. NUMBERS WILL READ FROM LEFT TO RIGHT WITH 1, 2, AND 3 ON THE TOP, OR KEYWAY SIDE.
  9. NUMBERED CIRCLE ON RIGHT SIDE OF SHEET SIGNIFIES "GO TO NEXT SHEET" AND FIND SAME NUMBER ON LEFT SIDE OF SHEET WITH MATCHING WIRE NUMBER(S).

406475-530-5  
J0913

Figure FO-31. Mast Mounted Sight (MMS) System Wiring Diagram OH-58D(R) (Sheet 5 of 5)

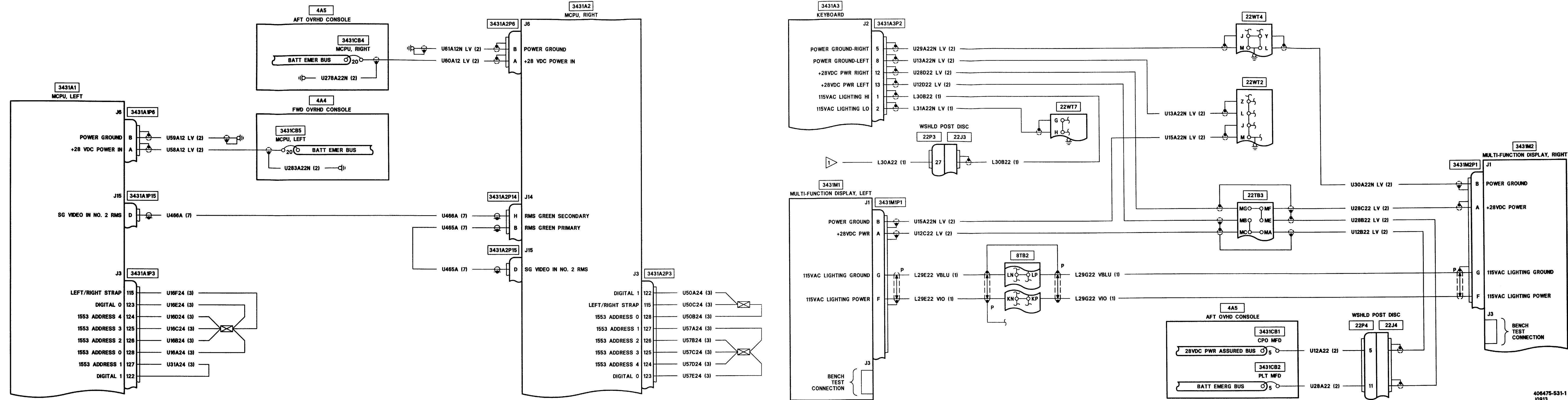

Figure FO-32. Control Display System (CDS) Wiring Diagram OH-58D(R) (Sheet 1 of 10)

406475-531-1  
J0913



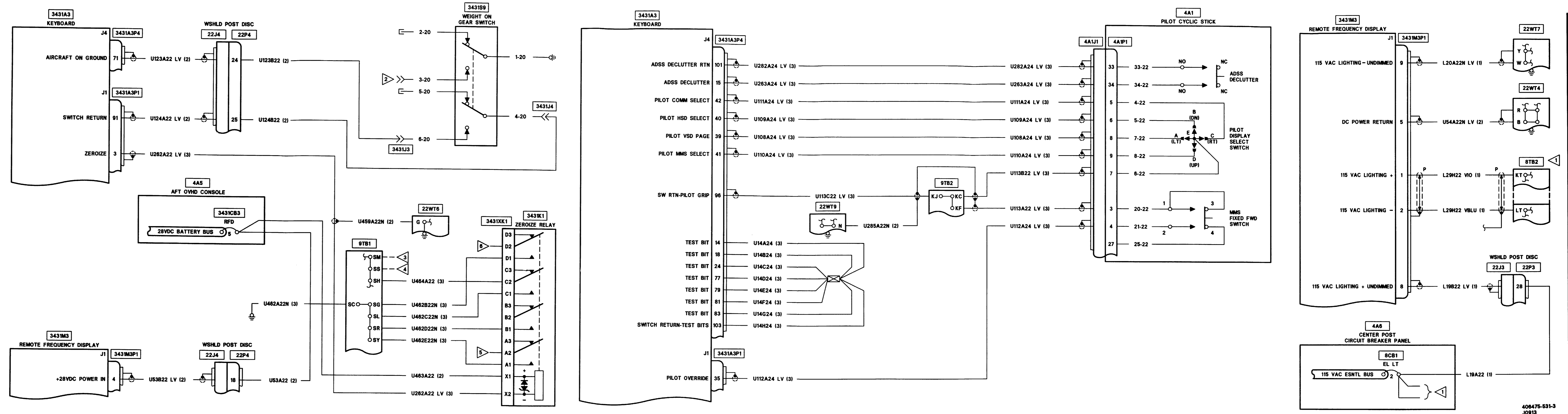

Figure FO-32. Control Display System (CDS) Wiring Diagram OH-58D(R) (Sheet 3 of 10)

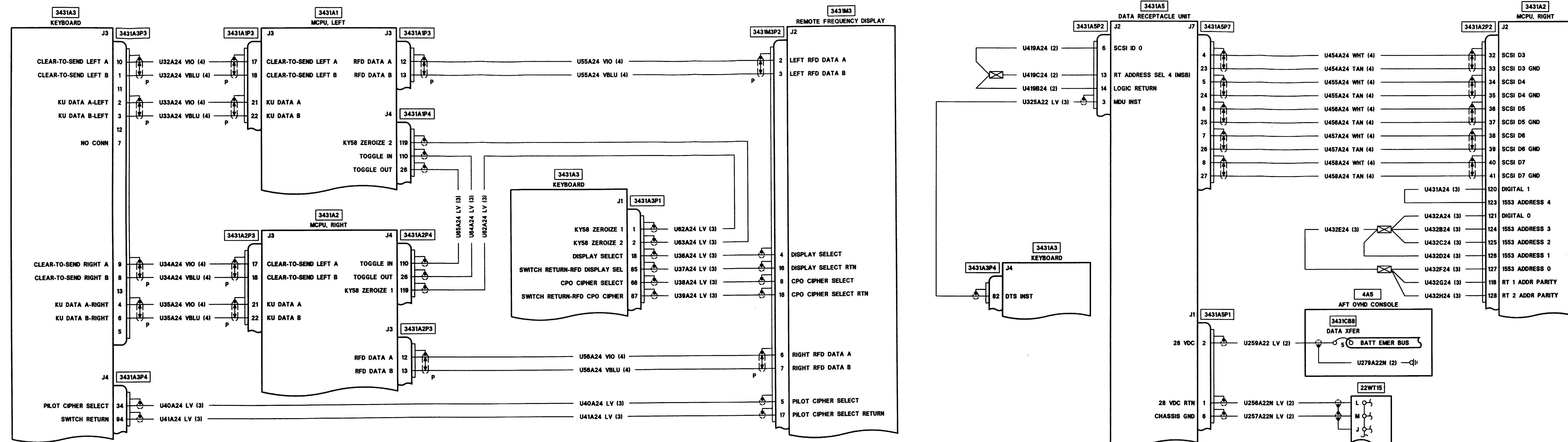

Figure FO-32. Control Display System (CDS) Wiring Diagram OH-58D(R) (Sheet 4 of 10)

406475-531-4  
J0913

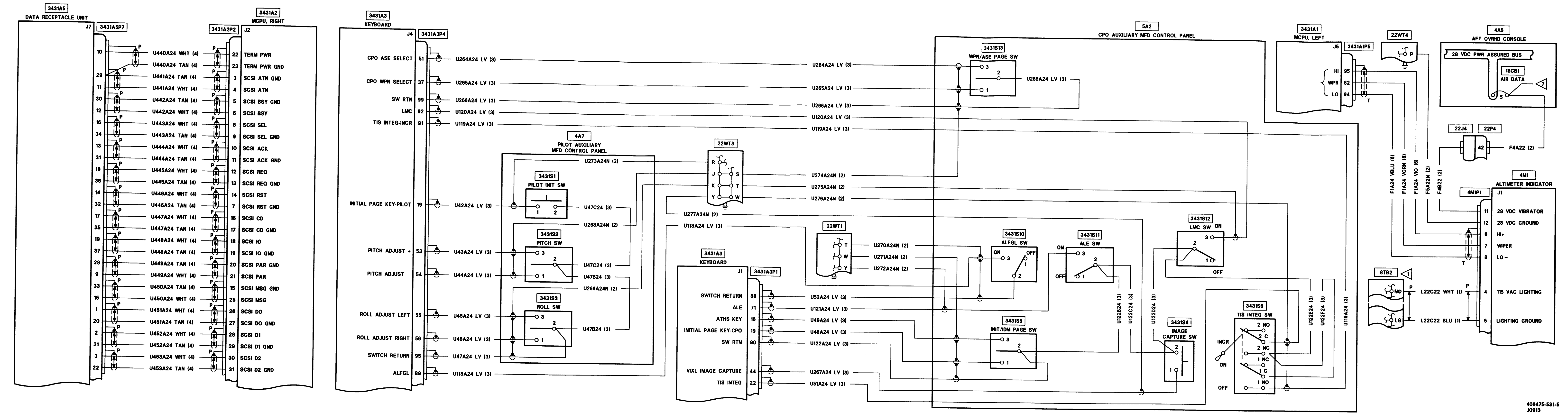
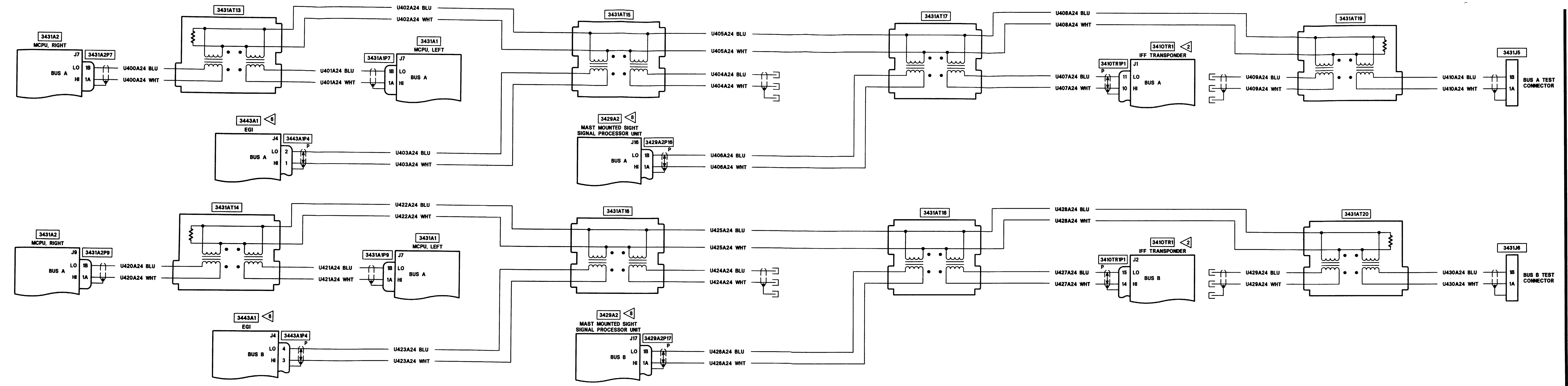

Figure FO-32. Control Display System (CDS) Wiring Diagram OH-58D(R) (Sheet 5 of 10)

408475-531-5 J0913





406475-531-6  
J0913

Figure FO-32. Control Display System (CDS) Wiring Diagram OH-58D(R) (Sheet 6 of 10)

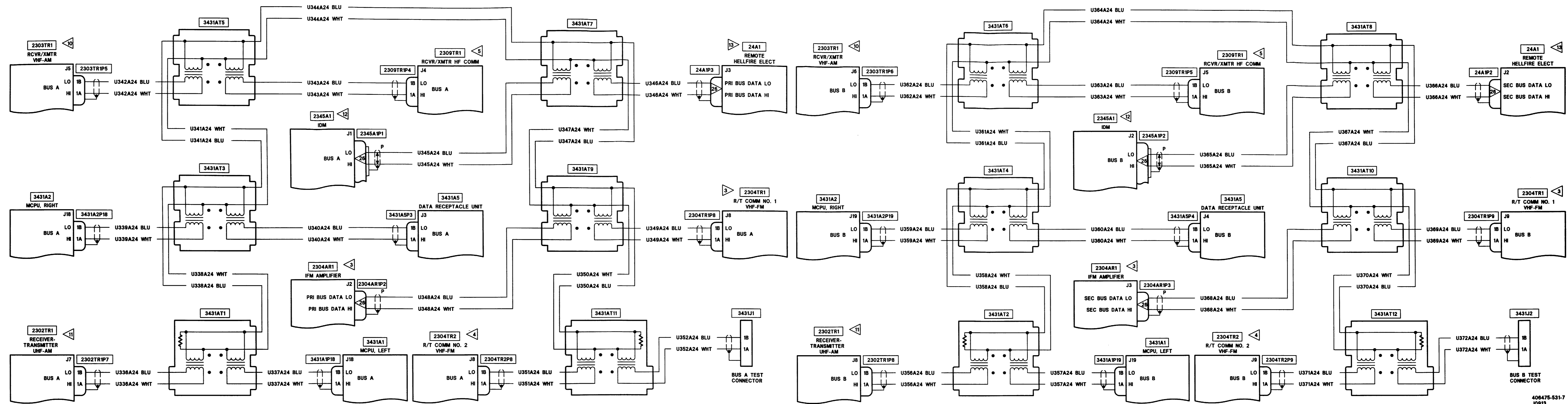

Figure FO-32. Control Display System (CDS) Wiring Diagram OH-58D(R) (Sheet 7 of 10)

406475-531-7  
J0913

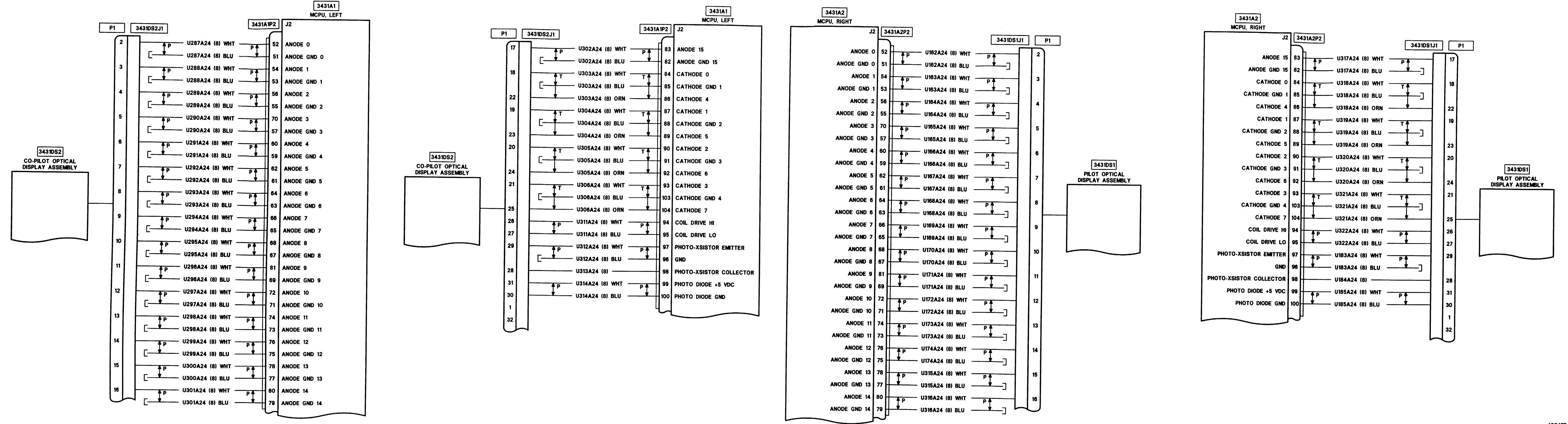
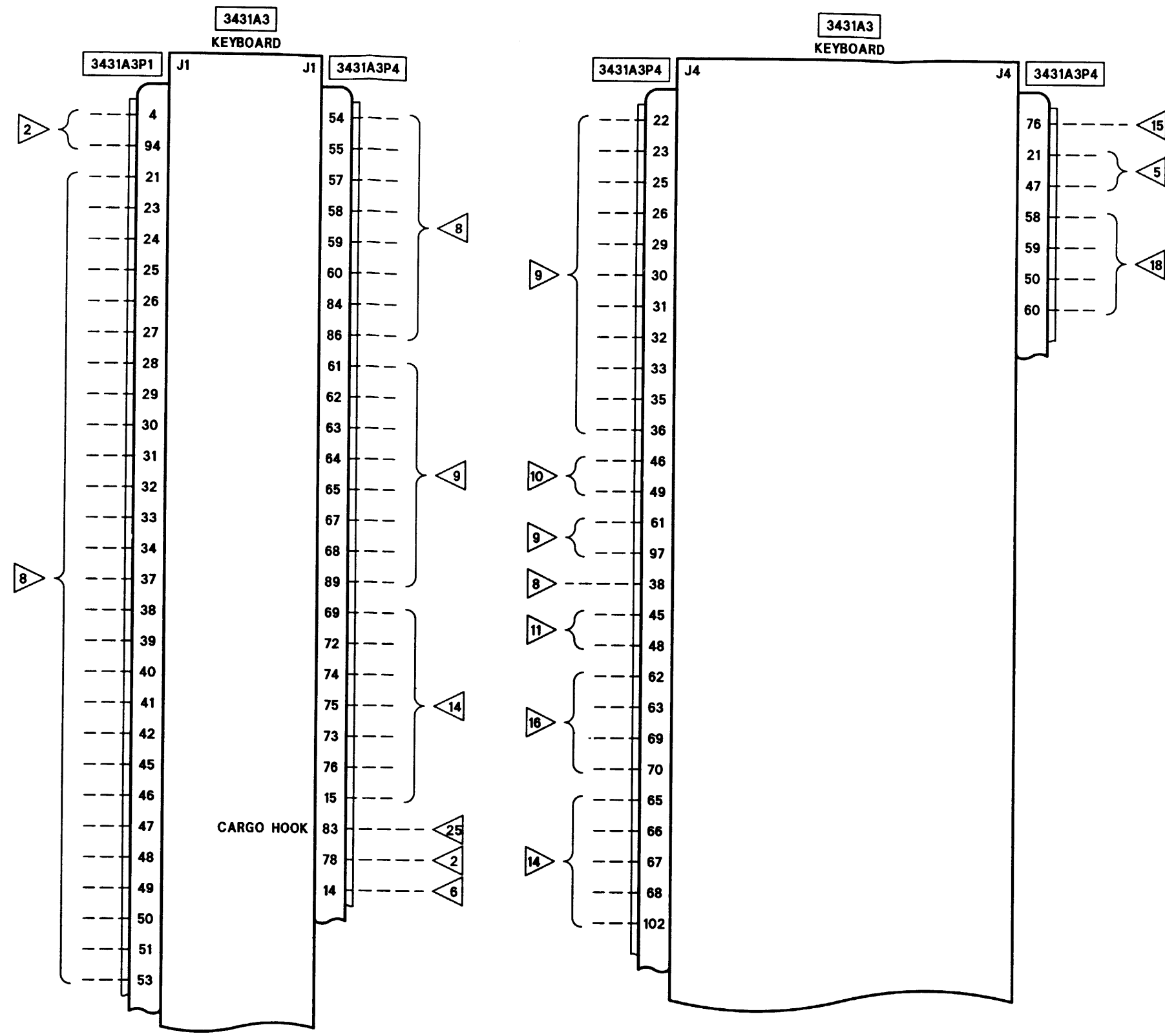

Figure FO-32. Control Display System (CDS) Wiring Diagram OH-58D(R) (Sheet 8 of 10)





- NOTES
- 1 REFER TO LIGHTING WIRING DIAGRAM.
  - 2 REFER TO IFF WIRING DIAGRAM TM 11-1520-248-23.
  - 3 REFER TO NO. 1 VHF-FM COMM WIRING DIAGRAM TM 11-1520-248-23.
  - 4 REFER TO NO. 2 VHF-FM COMM WIRING DIAGRAM TM 11-1520-248-23.
  - 5 REFER TO HF WIRING DIAGRAM TM 11-1520-248-23.
  - 6 REFER TO EGI WIRING DIAGRAM TM 11-1520-248-23.
  - 7 REFER TO AIR DATA SYSTEM WIRING DIAGRAM.
  - 8 REFER TO MAST MOUNTED SIGHT (MMS) SYSTEM WIRING DIAGRAM.
  - 9 REFER TO ICS WIRING DIAGRAM TM 11-1520-248-23.
  - 10 REFER TO VHF-AM COMM WIRING DIAGRAM TM 11-1520-248-23.
  - 11 REFER TO UHF-AM COMM WIRING DIAGRAM TM 11-1520-248-23.
  - 12 REFER TO IDM WIRING DIAGRAM TM 11-1520-248-23.
  - 13 REFER TO HELLFIRE SYSTEM WIRING DIAGRAM.
  - 14 REFER TO POWERPLANT AND TRANSMISSION WIRING DIAGRAM.
  - 15 REFER TO SCAS, HYDRAULICS, AND STANDBY ATTITUDE GYRO SYSTEM WIRING DIAGRAM.
  - 16 REFER TO DC POWER SYSTEM WIRING DIAGRAM.
  - 17 REFER TO RADAR ALTIMETER WIRING DIAGRAM TM 11-1520-248-23.
  - 18 REFER TO GUNS AND ROCKETS SYSTEM WIRING DIAGRAM.
  - 19 REFER TO TRANSMISSION ATTITUDE MEASUREMENT SYSTEM WIRING DIAGRAM.
  - 20 REFER TO AC POWER SYSTEM WIRING DIAGRAM.

406475-531-10  
J0913

Figure FO-32. Control Display System (CDS) Wiring Diagram OH-58D(R) (Sheet 10 of 10)

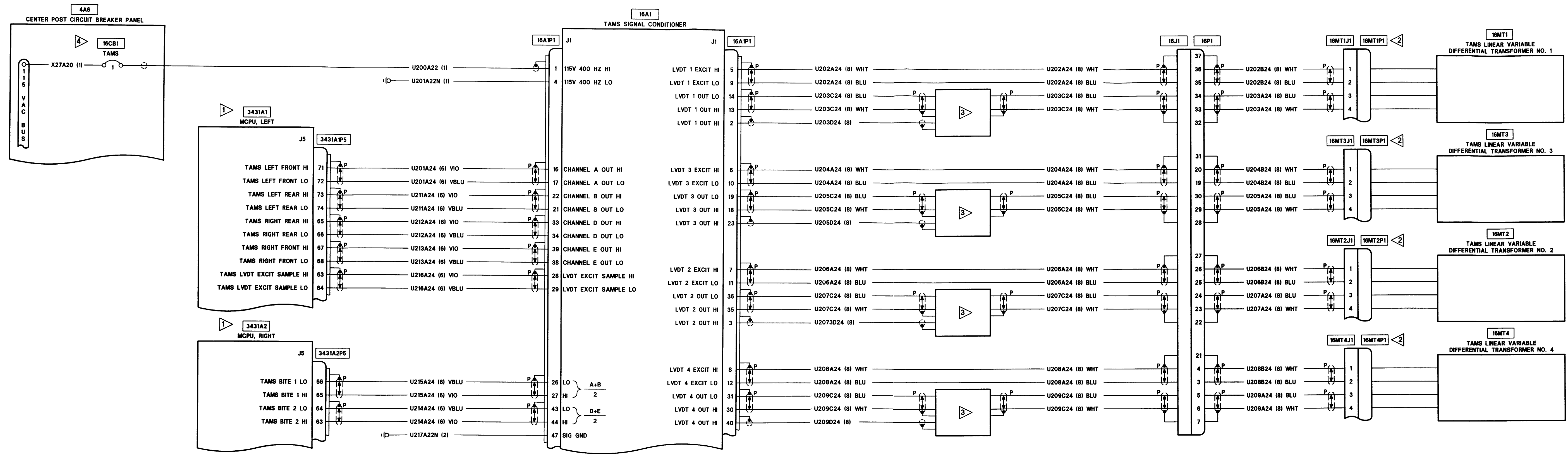

- NOTES
- REFER TO CONTROL DISPLAY SYSTEM (CDS) WIRING DIAGRAM.
  - CABLES AND CONNECTOR ARE INCLUDED AS PART OF TRANSFORMER UNITS.
  - SINGLE CONDUCTOR SHIELDED CABLE IS ELECTRICALLY BUSSED WITH WHITE CONDUCTORS OF TWO CONDUCTOR SHIELDED CABLES.
  - REFER TO AC POWER SYSTEM WIRING DIAGRAM.

Figure FO-33. Transmission Attitude Measurement System (TAMS) Wiring Diagram OH-58D(R)

406475-533  
JOB13

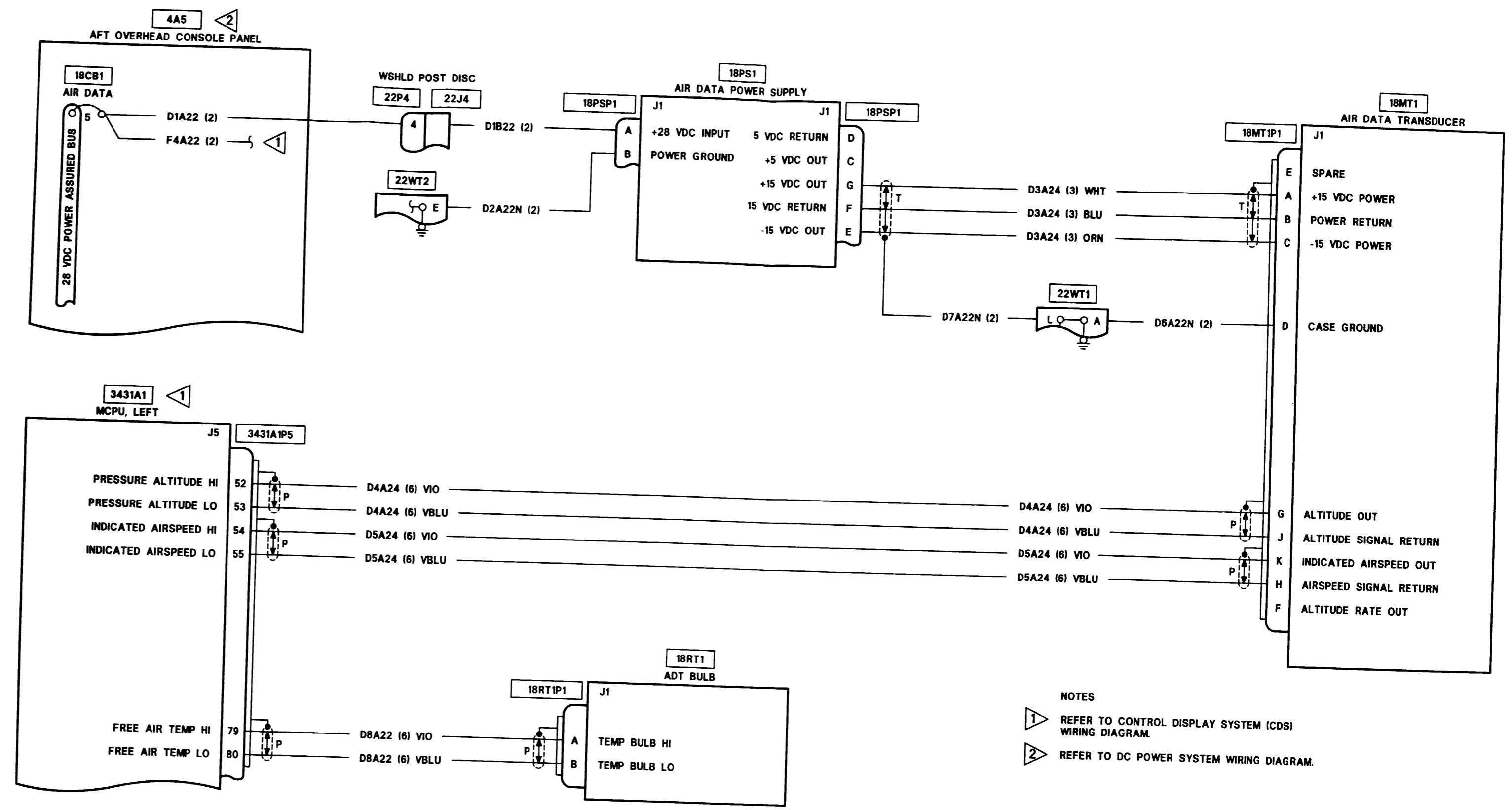

NOTES  
 1 REFER TO CONTROL DISPLAY SYSTEM (CDS) WIRING DIAGRAM.  
 2 REFER TO DC POWER SYSTEM WIRING DIAGRAM.

406475-534  
 J0913

Figure FO-34. Air Data System (ADS) Wiring Diagram OH-58D(R)

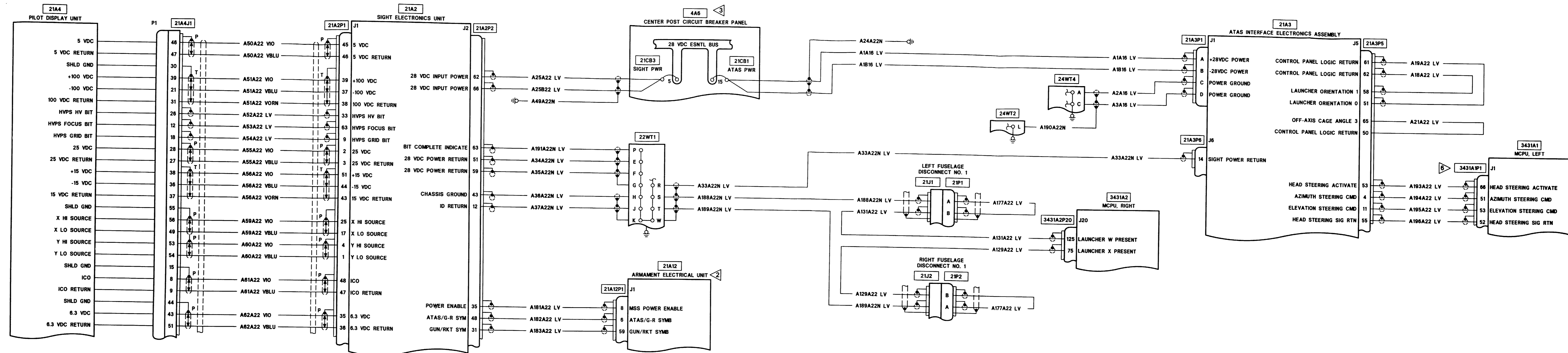

Figure FO-35. Air-to-Air Stinger (ATAS) Missile System Wiring Diagram OH-58D(R) (Sheet 1 of 6)

406475-535-1  
J0913



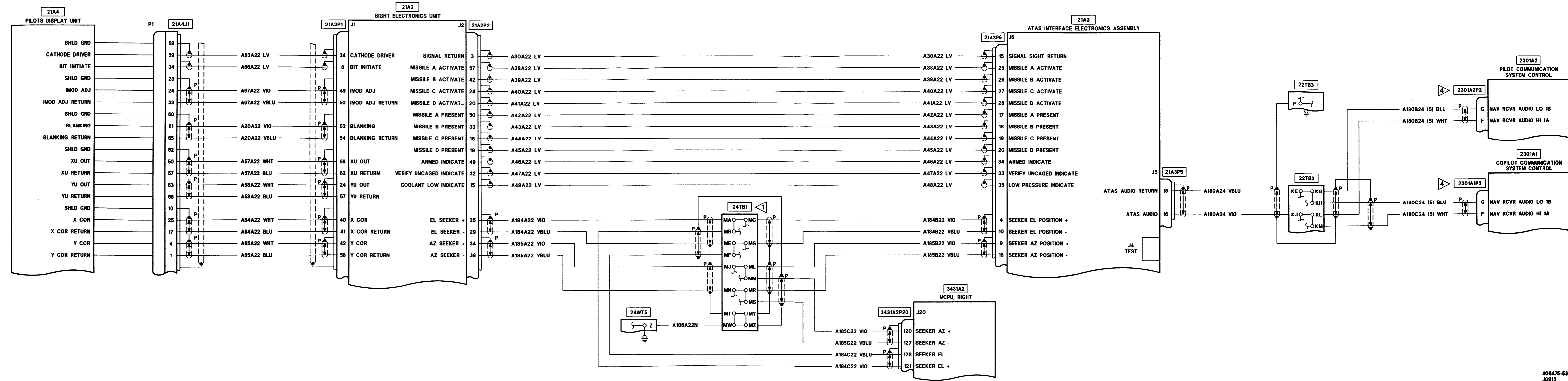

Figure FO-35. Air-to-Air Stinger (ATAS) Missile System Wiring Diagram OH-58D(R) (Sheet 2 of 6)

406475-535-2  
J0913

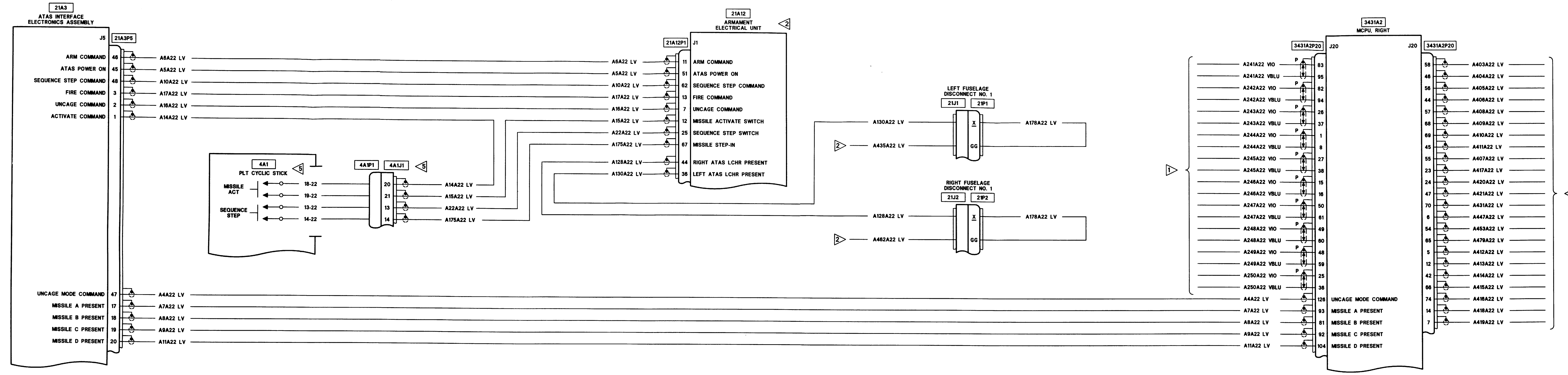
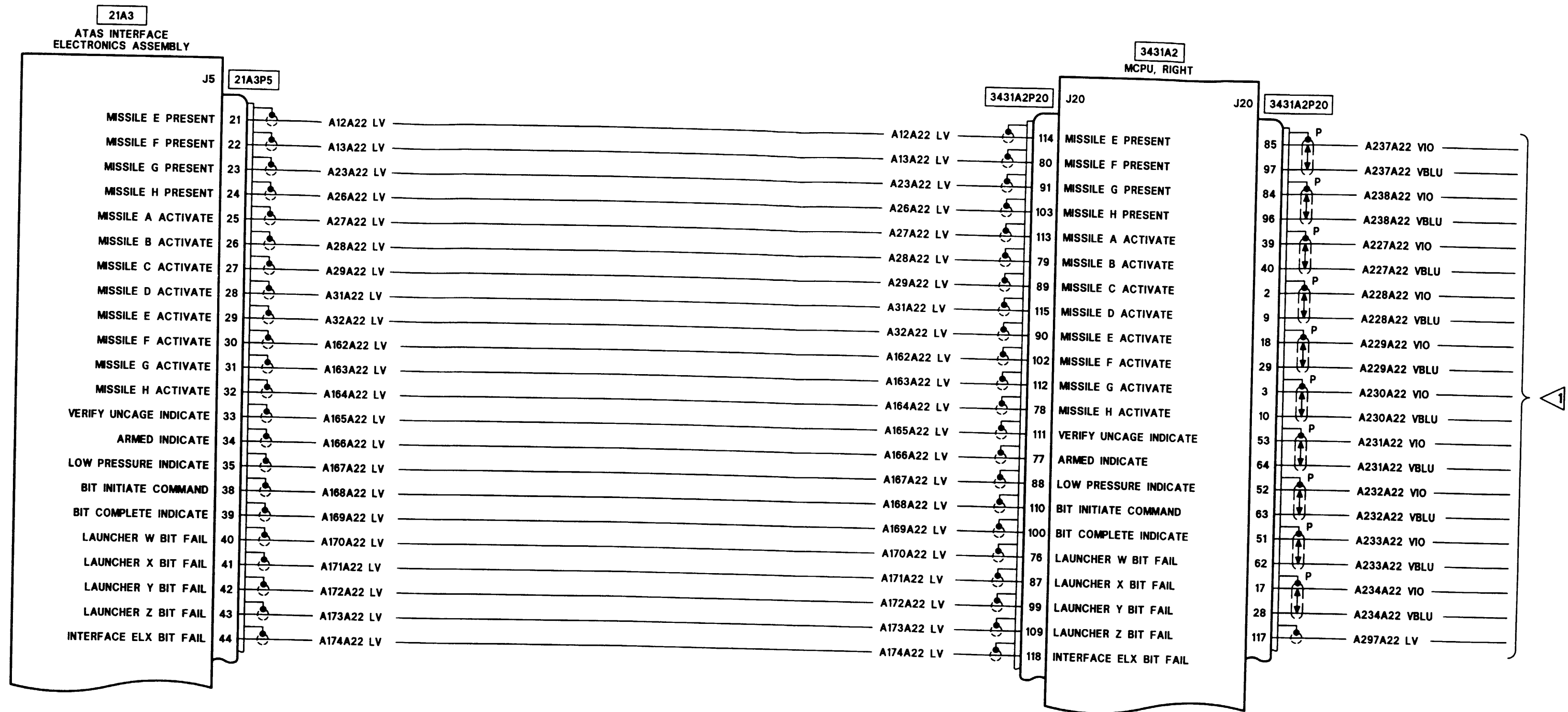

Figure FO-35. Air-to-Air Stinger (ATAS) Missile System Wiring Diagram OH-58D(R) (Sheet 3 of 6)

408475-535-3  
J0913



406475-535-4  
J0913

Figure FO-35. Air-to-Air Stinger (ATAS) Missile System Wiring Diagram OH-58D(R) (Sheet 4 of 6)

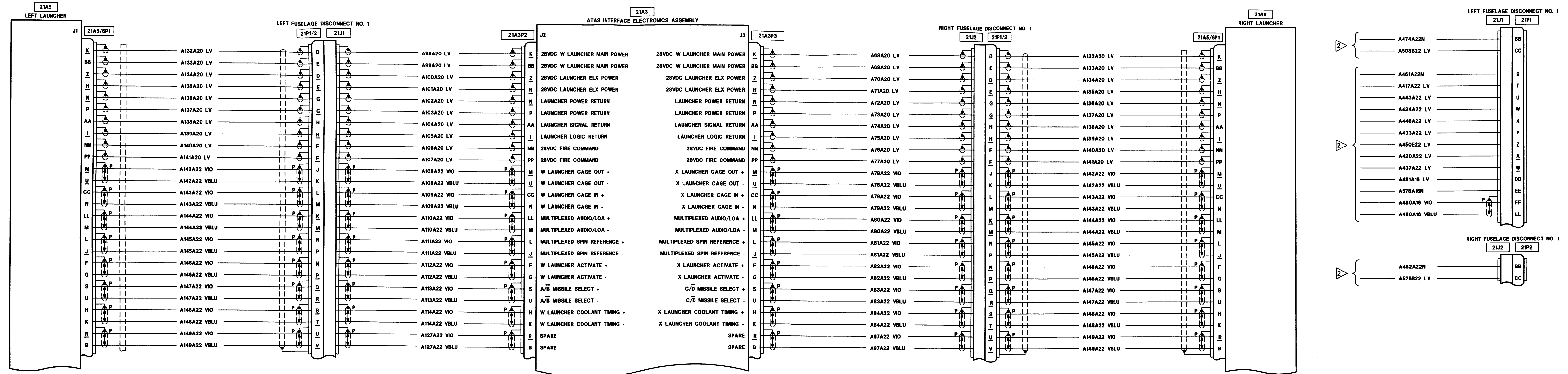
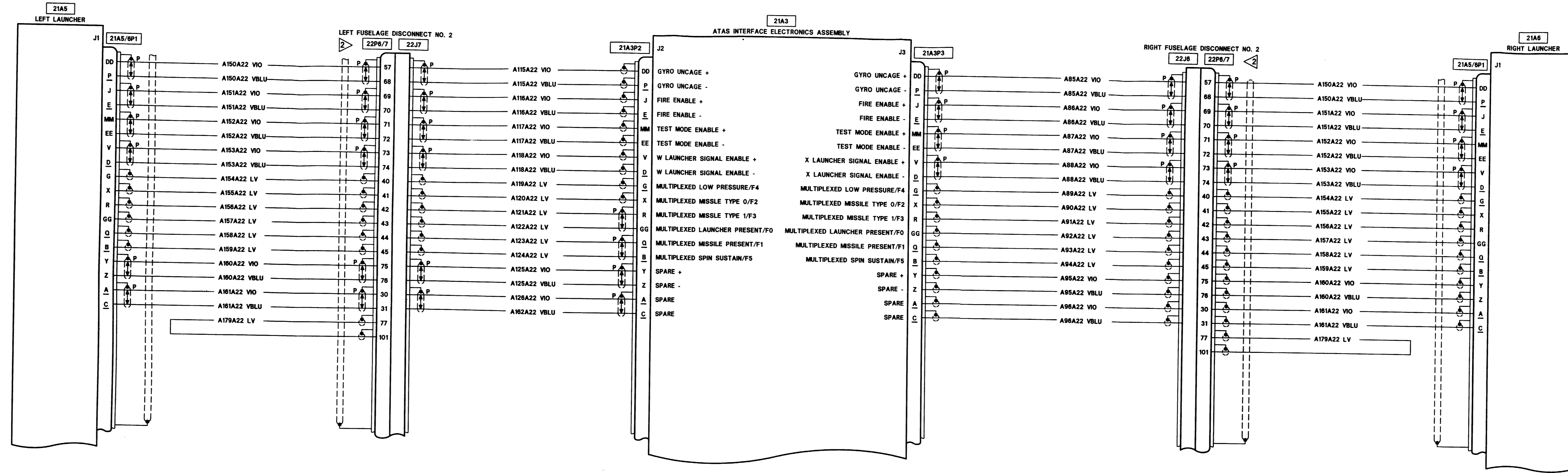

Figure FO-35. Air-to-Air Stinger (ATAS) Missile System Wiring Diagram OH-58D(R) (Sheet 5 of 6)

408475-535-5 J0913



- NOTES:
- 1 REFER TO HELLFIRE SYSTEM WIRING DIAGRAM.
  - 2 REFER TO GUNS AND ROCKETS WIRING DIAGRAM.
  - 3 REFER TO DC POWER SYSTEM WIRING DIAGRAM.
  - 4 REFER TO ICS SYSTEM WIRING DIAGRAM TM 11-1520-248-23.
  - 5 REFER TO SCAS, HYDRAULIC, AND STANDBY ATTITUDE GYRO SYSTEM WIRING DIAGRAM.
  - 6 REFER TO VIDEO TAPE RECORDER WIRING DIAGRAM TM 11-1520-248-23.

406475-535-6  
J0913

Figure FO-35. Air-to-Air Stinger (ATAS) Missile System Wiring Diagram OH-58D(R) (Sheet 6 of 6)

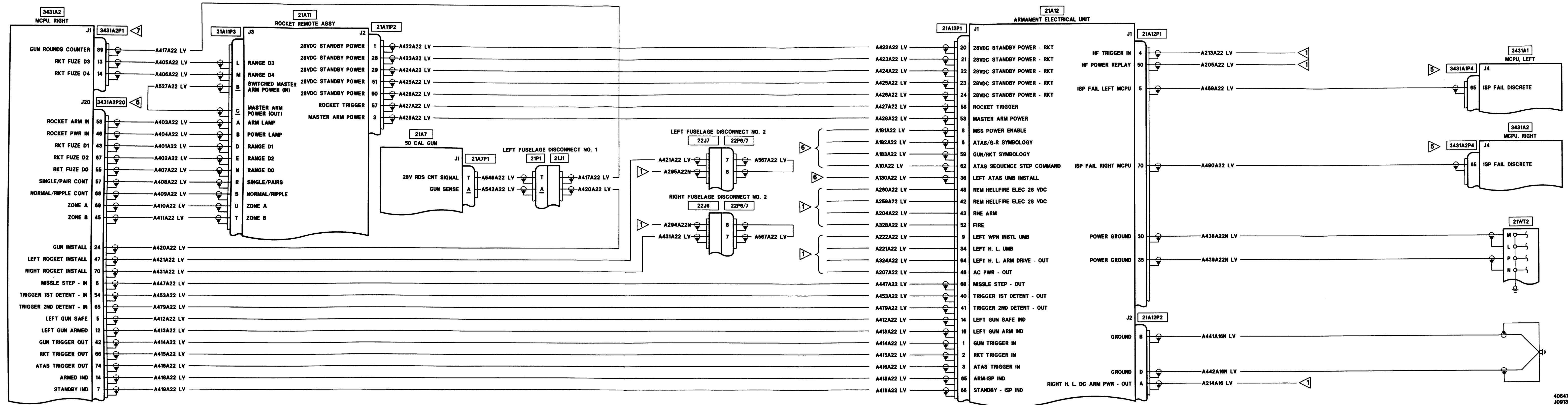
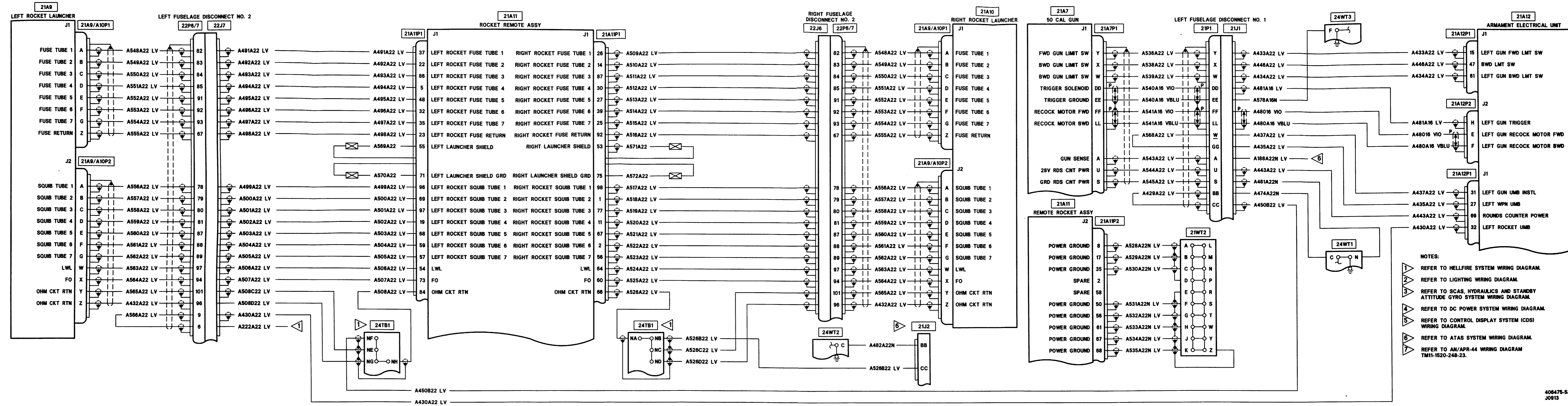

Figure FO-36. Guns and Rockets System Wiring Diagram OH-58D(R) (Sheet 1 of 4)









- NOTES:
- 1 REFER TO HELLFIRE SYSTEM WIRING DIAGRAM.
  - 2 REFER TO LIGHTING WIRING DIAGRAM.
  - 3 REFER TO SCAS, HYDRAULICS AND STANDBY ATTITUDE GYRO SYSTEM WIRING DIAGRAM.
  - 4 REFER TO DC POWER SYSTEM WIRING DIAGRAM.
  - 5 REFER TO CONTROL DISPLAY SYSTEM (CDS) WIRING DIAGRAM.
  - 6 REFER TO ATAS SYSTEM WIRING DIAGRAM.
  - 7 REFER TO AN/APR-44 WIRING DIAGRAM TM11-1520-248-23.

Figure FO-36. Guns and Rockets System Wiring Diagram OH-58D(R) (Sheet 4 of 4)

406475-536-4  
J0913

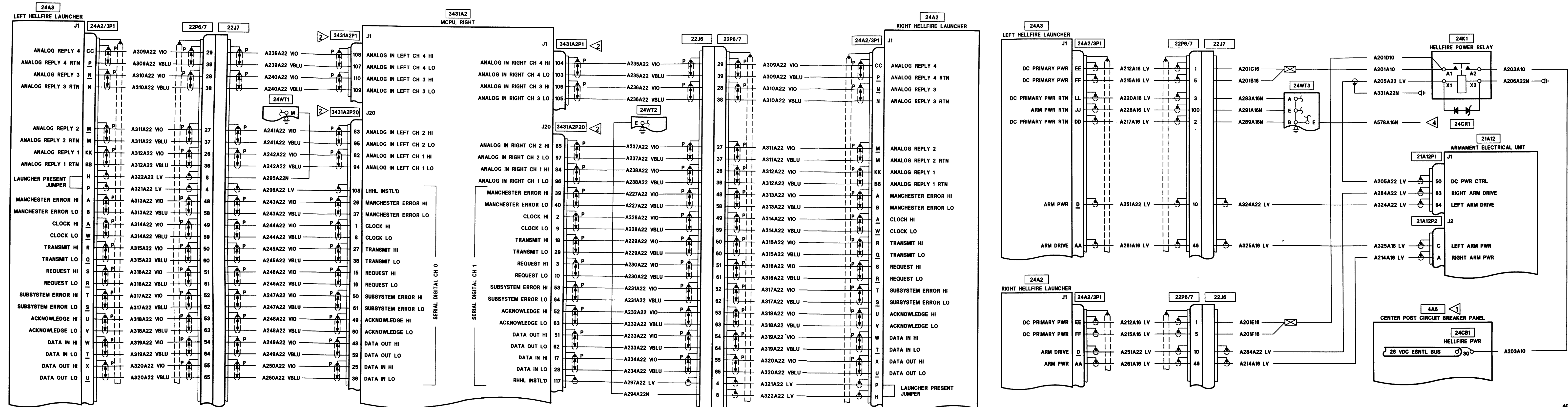
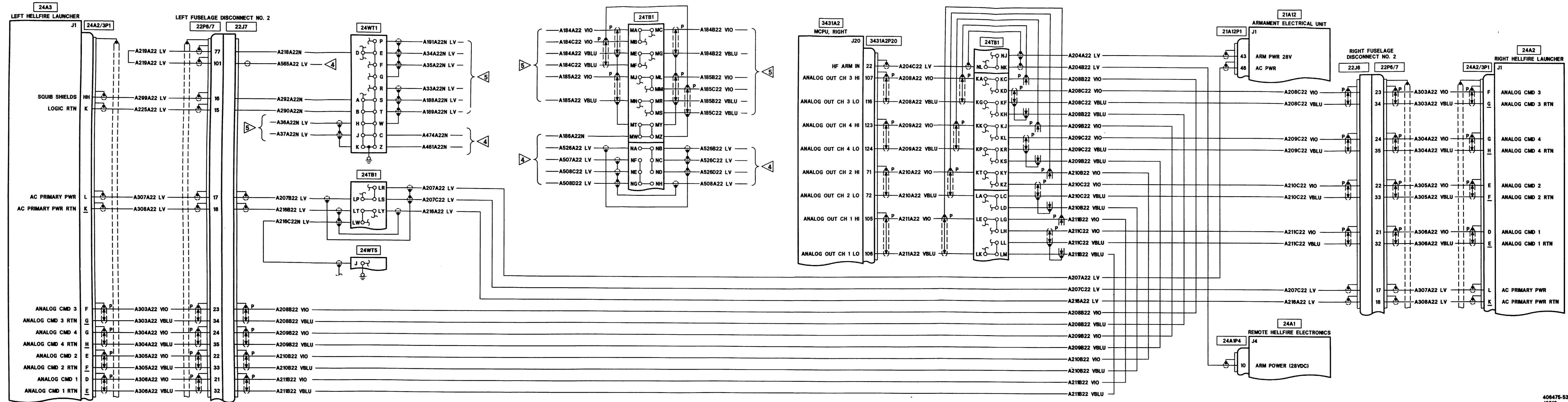

Figure FO-37. HELLFIRE Missile System (HMS) Wiring Diagram OH-58D(R) (Sheet 1 of 3)

406475-537-1  
J0913



408475-537-2  
JOB19

Figure FO-37. HELLFIRE Missile System (HMS) Wiring Diagram OH-58D(R) (Sheet 2 of 3)



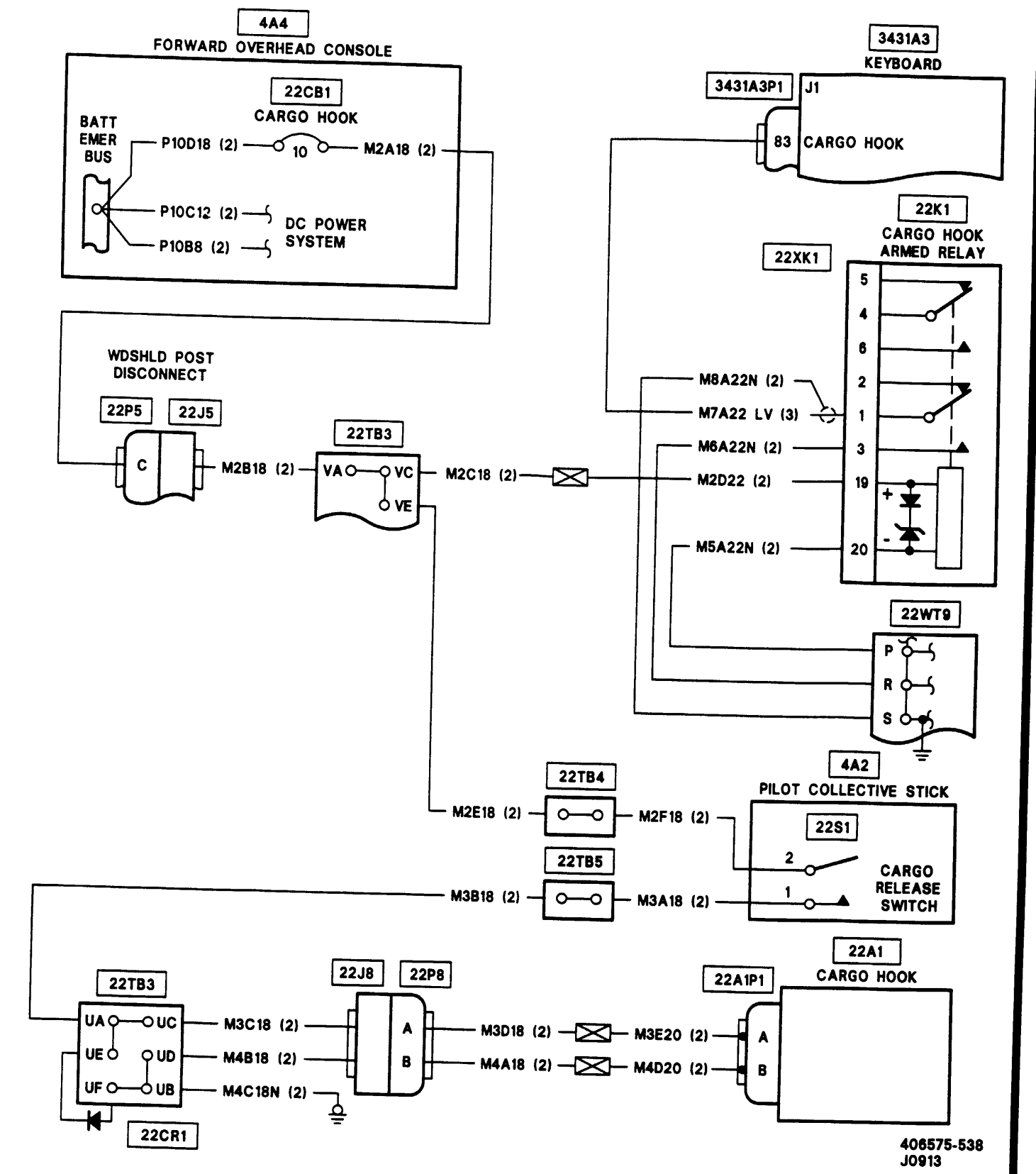

406575-538  
J0913

Figure FO-38. Cargo Hook System Wiring Diagram OH-58D(R)

By Order of the Secretary of the Army:

Official:

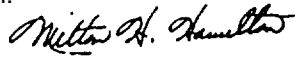

MILTON H. HAMILTON  
*Administrative Assistant to the  
Secretary of the Army*  
01128

GORDON R. SULLIVAN  
*General, United States Army  
Chief of Staff*

DISTRIBUTION :

To be distributed in accordance with DA Form 12-31-E, block number 1435, AVUM and AVIM maintenance requirements for TM 55-1520-248-23-9.



RECOMMENDED CHANGES TO EQUIPMENT TECHNICAL PUBLICATIONS



THEN... JOT DOWN THE DOPE ABOUT IT ON THIS FORM. CAREFULLY TEAR IT OUT. FOLD IT AND DROP IT IN THE MAIL!

SOMETHING WRONG WITH THIS PUBLICATION?

FROM: (PRINT YOUR UNIT'S COMPLETE ADDRESS)

PFC JOHN DOE  
COA, 3d ENGINEER BN  
FT. LEONARDWOOD, MO 63108

DATE SENT

PUBLICATION NUMBER

TM 55-1520-248-23-9

PUBLICATION DATE

31 March 1992

PUBLICATION TITLE

Army Model OH-58D Helicopter

BE EXACT PIN-POINT WHERE IT IS

PAGE NO	PARA-GRAPH	FIGURE NO	TABLE NO
6	2-1 a		
B1		4-3	
125	line 20		

IN THIS SPACE TELL WHAT IS WRONG AND WHAT SHOULD BE DONE ABOUT IT:

In line 6 of paragraph 2-1a the manual states the engine has 6 cylinders. The engine on my set only has 4 cylinders. Change the manual to show 4 cylinders.

Callout 16 on figure 4-3 is pointing at a bolt. In key to figure 4-3, item 16 is called a shim. Please correct one or the other.

I ordered a gasket, item 19 on figure B-16 by NSN 2 910-00-762-3001. I got a gasket but it doesn't fit. Supply says I got what I ordered, so the NSN is wrong. Please give me a good NSN

PRINTED NAME, GRADE OR TITLE, AND TELEPHONE NUMBER

JOHN DOE, PFC (268) 317-7111

SIGN HERE

JOHN DOE

DA FORM 2028-2  
1 JUL 79

PREVIOUS EDITIONS ARE OBSOLETE.

DRSTS-M Overprint 1, 1 Nov 80

PS --IF YOUR OUTFIT WANTS TO KNOW ABOUT YOUR RECOMMENDATION MAKE A CARBON COPY OF THIS AND GIVE IT TO YOUR HEADQUARTERS

TEAR ALONG PERFORATED LINE



1 Nov 80

FILL IN YOUR  
UNITS ADDRESS



FOLD BACK

DEPARTMENT OF THE ARMY

---

---

OFFICAL BUSINESS

COMMANDER  
U.S. ARMY AVIATION AND TROOP COMMAND  
ATTN: AMSAT-I-MP  
4300 GOODFELLOW BOULEVARD  
ST. LOUIS, MO 63120-1798

TEAR ALONG PERFORATED LINE

RECOMMENDED CHANGES TO EQUIPMENT TECHNICAL PUBLICATIONS



THEN... JOT DOWN THE DOPE ABOUT IT ON THIS FORM. CAREFULLY TEAR IT OUT, FOLD IT AND DROP IT IN THE MAIL!

**SOMETHING WRONG WITH THIS PUBLICATION?**

FROM: (PRINT YOUR UNIT'S COMPLETE ADDRESS)

DATE SENT

PUBLICATION NUMBER

TM 55-1520-248-23-9

PUBLICATION DATE

31 March 1992

PUBLICATION TITLE

Army Model OH-58D Helicopter

BE EXACT PIN-POINT WHERE IT IS

PAGE NO

PARA-GRAPH

FIGURE NO

TABLE NO

IN THIS SPACE TELL WHAT IS WRONG AND WHAT SHOULD BE DONE ABOUT IT:

TEAR ALONG PERFORATED LINE

PRINTED NAME, GRADE OR TITLE AND TELEPHONE NUMBER

SIGN HERE

DA FORM 2028-2  
1 JUL 79

PREVIOUS EDITIONS ARE OBSOLETE.  
DRST-M Overprint 2, 1 Nov 88.

PS--IF YOUR OUTFIT WANTS TO KNOW ABOUT YOUR RECOMMENDATION MAKE A CARBON COPY OF THIS AND GIVE IT TO YOUR HEADQUARTERS

1 Nov 80

FILL IN YOUR  
UNITS ADDRESS



FOLD BACK

DEPARTMENT OF THE ARMY

---

---

OFFICAL BUSINESS

COMMANDER  
U.S. ARMY AVIATION AND TROOP COMMAND  
ATTN: AMSAT-I-MP  
4300 GOODFELLOW BOULEVARD  
ST. LOUIS, MO 63120-1798

TEAR ALONG PERFORATED LINE

RECOMMENDED CHANGES TO EQUIPMENT TECHNICAL PUBLICATIONS



THEN... JOT DOWN THE DOPE ABOUT IT ON THIS FORM. CAREFULLY TEAR IT OUT. FOLD IT AND DROP IT IN THE MAIL!

**SOMETHING WRONG WITH THIS PUBLICATION?**

FROM: (PRINT YOUR UNIT'S COMPLETE ADDRESS)

DATE SENT

PUBLICATION NUMBER

TM 55-1520-248-23-9

PUBLICATION DATE

31 March 1992

PUBLICATION TITLE

Army Model OH-58D Helicopter

BE EXACT PIN-POINT WHERE IT IS

PAGE NO	PARA-GRAPH	FIGURE NO	TABLE NO
---------	------------	-----------	----------

IN THIS SPACE TELL WHAT IS WRONG AND WHAT SHOULD BE DONE ABOUT IT:

TEAR ALONG PERFORATED LINE

PRINTED NAME, GRADE OR TITLE AND TELEPHONE NUMBER

SIGN HERE

DA FORM 2028-2 JUL 79

PREVIOUS EDITIONS ARE OBSOLETE.  
DRSTS-M Overprint 2, 1 Nov 88.

P.S.--IF YOUR OUTFIT WANTS TO KNOW ABOUT YOUR RECOMMENDATION MAKE A CARBON COPY OF THIS AND GIVE IT TO YOUR HEADQUARTERS

1 Nov 80

FILL IN YOUR  
UNITS ADDRESS



FOLD BACK

DEPARTMENT OF THE ARMY

---

---

OFFICAL BUSINESS

COMMANDER  
U.S. ARMY AVIATION AND TROOP COMMAND  
ATTN: AMSAT-I-MP  
4300 GOODFELLOW BOULEVARD  
ST. LOUIS, MO 63120-1798

TEAR ALONG PERFORATED LINE



1 Nov 80

FILL IN YOUR  
UNITS ADDRESS



FOLD BACK

DEPARTMENT OF THE ARMY

---

---

OFFICAL BUSINESS

COMMANDER  
U.S. ARMY AVIATION AND TROOP COMMAND  
ATTN: AMSAT-I-MP  
4300 GOODFELLOW BOULEVARD  
ST. LOUIS, MO 63120-1798

TEAR ALONG PERFORATED LINE







# The Metric System and Equivalents

## Linear Measure

1 centimeter = 10 millimeters = .39 inch  
 1 decimeter = 10 centimeters = 3.94 inches  
 1 meter = 10 decimeters = 39.37 inches  
 1 dekameter = 10 meters = 32.8 feet  
 1 hectometer = 10 dekameters = 328.08 feet  
 1 kilometer = 10 hectometers = 3,280.8 feet

## Weights

1 centigram = 10 milligrams = .15 grain  
 1 decigram = 10 centigrams = 1.54 grains  
 1 gram = 10 decigrams = .035 ounce  
 1 dekagram = 10 grams = .35 ounce  
 1 hectogram = 10 dekagrams = 3.52 ounces  
 1 kilogram = 10 hectograms = 2.2 pounds  
 1 quintal = 100 kilograms = 220.46 pounds  
 1 metric ton = 10 quintals = 1.1 short tons

## Liquid Measure

1 centiliter = 10 milliliters = .34 fl. ounce  
 1 deciliter = 10 centiliters = 3.38 fl. ounces  
 1 liter = 10 deciliters = 33.81 fl. ounces  
 1 dekaliter = 10 liters = 2.64 gallons  
 1 hectoliter = 10 dekaliters = 26.42 gallons  
 1 kiloliter = 10 hectoliters = 264.18 gallons

## Square Measure

1 sq. centimeter = 100 sq. millimeters = .155 sq. inch  
 1 sq. decimeter = 100 sq. centimeters = 15.5 sq. inches  
 1 sq. meter (centare) = 100 sq. decimeters = 10.76 sq. feet  
 1 sq. dekameter (are) = 100 sq. meters = 1,076.4 sq. feet  
 1 sq. hectometer (hectare) = 100 sq. dekameters = 2.47 acres  
 1 sq. kilometer = 100 sq. hectometers = .386 sq. mile

## Cubic Measure

1 cu. centimeter = 1000 cu. millimeters = .06 cu. inch  
 1 cu. decimeter = 1000 cu. centimeters = 61.02 cu. inches  
 1 cu. meter = 1000 cu. decimeters = 35.31 cu. feet

## Approximate Conversion Factors

To change	To	Multiply by	To change	To	Multiply by
inches	centimeters	2.540	ounce-inches	newton-meters	.007062
feet	meters	.305	centimeters	inches	.394
yards	meters	.914	meters	feet	3.280
miles	kilometers	1.609	meters	yards	1.094
square inches	square centimeters	6.451	kilometers	miles	.621
square feet	square meters	.093	square centimeters	square inches	.155
square yards	square meters	.836	square meters	square feet	10.764
square miles	square kilometers	2.590	square meters	square yards	1.196
acres	square hectometers	.405	square kilometers	square miles	.386
cubic feet	cubic meters	.028	square hectometers	acres	2.471
cubic yards	cubic meters	.765	cubic meters	cubic feet	35.315
fluid ounces	milliliters	29.573	cubic meters	cubic yards	1.308
pints	liters	.473	milliliters	fluid ounces	.034
quarts	liters	.946	liters	pints	2.113
gallons	liters	3.785	liters	quarts	1.057
ounces	grams	28.349	liters	gallons	.264
pounds	kilograms	.454	grams	ounces	.035
short tons	metric tons	.907	kilograms	pounds	2.205
pound-feet	newton-meters	1.356	metric tons	short tons	1.102
pound-inches	newton-meters	.11296			

## Temperature (Exact)

°F	Fahrenheit temperature	5/9 (after subtracting 32)	Celsius temperature	°C
----	------------------------	----------------------------	---------------------	----

